

UNCONTROLLED DOCUMENT

SC:1	PART NUMBER	REV.
LCM-S01602DSR35480		A
REV.	E.C.N. NUMBER AND REVISION COMMENTS	DATE
A	E.C.N. #11524.	08.12.08

UNDER REVISION

CHARACTER DETAIL

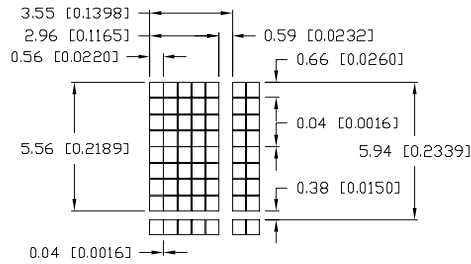

CAUTION: STATIC SENSITIVE DEVICE
FOLLOW PROPER E.S.D. HANDLING PROCEDURES
WHEN WORKING WITH THIS PART.

NOTES:

1. HEADER SIDE WITH 0.635mm DIAMETER PIN TO BE
INSERTED INTO PCB.

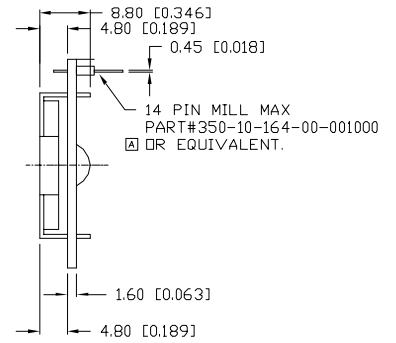
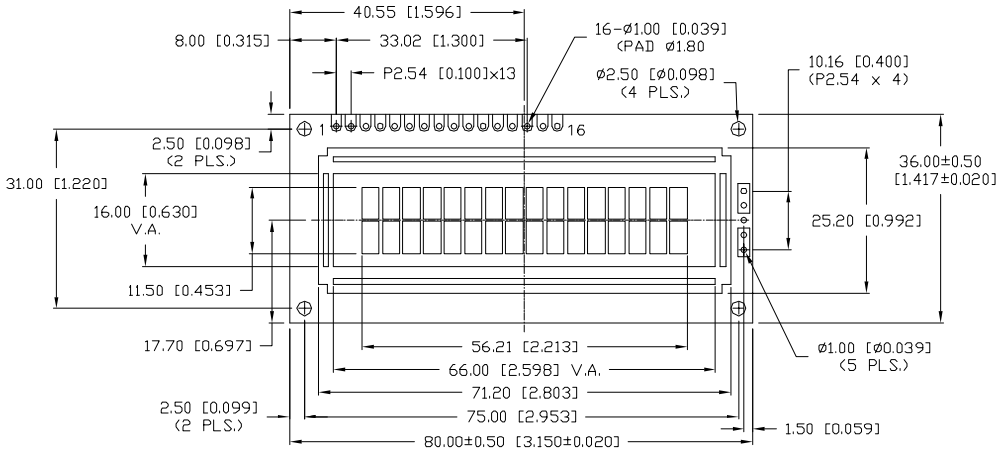

UNCONTROLLED DOCUMENT

*UNLESS OTHERWISE SPECIFIED TOLERANCES PER DECIMAL PRECISION ARE: X=±1 (±0.039), X.X=±0.5 (±0.020), X.XX=±0.25 (±0.010), X.XXX=±0.127 (±0.005). LEAD SIZE=±0.05 (±0.002), LEAD LENGTH=±0.75 (±0.030). MIN=+DECIMAL PRECISION -0.00 MAX.=+0.00 -DECIMAL PRECISION

REV.	PART NUMBER	<p>CONFIDENTIAL INFORMATION</p> <p>THE INFORMATION CONTAINED IN THIS DOCUMENT IS THE PROPERTY OF LUMEX INC. EXCEPT AS SPECIFICALLY AUTHORIZED IN WRITING BY LUMEX INC., THE HOLDER OF THIS DOCUMENT SHALL KEEP ALL INFORMATION CONTAINED HEREIN CONFIDENTIAL AND SHALL PROTECT SAME IN WHOLE OR IN PART FROM DISCLOSURE AND DISSEMINATION TO ALL THIRD PARTIES.</p> <p>RELIABILITY NOTE</p> <p>OUR MANY YEARS OF EXPERIENCE DATA ACCUMULATION INDICATE THAT SOLDER HEAT IS A MAJOR CAUSE OF EARLY AND FUTURE FAILURE. PLEASE PAY ATTENTION TO YOUR SOLDERING PROCESS.</p>	<p>290 E. HELEN ROAD PALATINE, IL 60067-6976 PHONE: +1.847.359.2790 US WEB: www.lumex.com TW WEB: www.lumex.com.tw</p>
A	LCM-S01602DSR35480		
<p>STN, REFLECTIVE, MILL MAX HEADER, 6:00 VIEW, 5.56mm CHARACTER HEIGHT, 5 x 8 DOT MATRIX, 16 x 2 LCD MODULE, 1/16 DUTY, 1/5 BIAS.</p>		<p>DRAWN BY: JD</p>	<p>CHECKED BY:</p>
		<p>APPROVED BY:</p>	<p>DATE: 09.26.06 PAGE: 1 OF 2 SCALE: N/A</p>

UNCONTROLLED DOCUMENT

SC:1	PART NUMBER	REV.
	LCM-S01602DSR35480	A
REV.	E.C.N. NUMBER AND REVISION COMMENTS	DATE
	SEE ON PAGE ONE.	

UNDER REVISION

PIN CONFIGURATION

PIN NO.	SYMBOL	LEVEL	FUNCTION
1	V _{SS}	-	POWER SUPPLY GND (0V)
2	V _{DD}	-	
3	V _O	-	
4	RS	H/L	REGISTER SELECT SIGNAL H: DATA INPUT L: INSTRUCTION INPUT
5	R/W	H/L	H: DATA READ (MODULE-->MPU) L: DATA WRITE (MODULE<--MPU)
6	E	H,H->L	ENABLE
7~14	DB0~DB7	H/L	DATA BUS--SOFTWARE SELECTABLE 4 OR 8 BIT MODE.
15			-
16			-

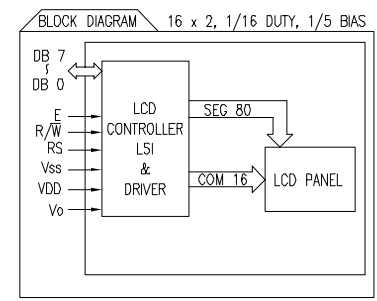
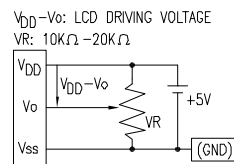

ELECTRICAL CHARACTERISTICS

V_{DD}=4.7V to 5.3V, T_A=25°C

ITEM	SYMBOL	CONDITION	STANDARD VALUE			UNIT
			MIN.	TYP.	MAX.	
SUPPLY VOLTAGE FOR LOGIC	V _{DD} -V _{SS}	-	-	5.0	-	V
SUPPLY CURRENT FOR LOGIC	I _{DD}	V _{DD} =5V	-	2.0	3.0	mA
INPUT VOLTAGE	HIGH	V _{IH}	-	2.2	-	V _{DD} V
	LOW	V _{IL}	-	0	-	0.6 V
OUTPUT VOLTAGE	HIGH	V _{OH}	-	2.4	-	V
	LOW	V _{OL}	-	-	0.4	V

ABSOLUTE MAXIMUM RATINGS

ITEM	SYMBOL	TEST CONDITION	STANDARD VALUE		UNIT
			MIN	MAX	
SUPPLY VOLTAGE FOR LOGIC	V _{DD} -V _{SS}	T _a =25°C	4.7	5.3	V
SUPPLY VOLTAGE FOR LCD DRIVE	V _{DD} -V _O	-	4.2@50°C	4.8@0°C	V
INPUT VOLTAGE	V _I	T _a =25°C	V _{SS}	V _{DD}	V
OPERATING TEMPERATURE	T _{opr}	LCM-S	0	50	°C
		LCM-H	-20	70	°C
STORAGE TEMPERATURE	T _{stg}	LCM-S	-20	70	°C
		LCM-H	-30	85	°C

UNCONTROLLED DOCUMENT

*UNLESS OTHERWISE SPECIFIED TOLERANCES PER DECIMAL PRECISION ARE: X=±1 (±0.039), X.X=±0.5 (±0.020), X.XX=±0.25 (±0.010), X.XXX=±0.127 (±0.005). LEAD SIZE=±0.05 (±0.002), LEAD LENGTH=±0.75 (±0.030) MIN.=+DECIMAL PRECISION MAX.= -DECIMAL PRECISION

REV. A	PART NUMBER LCM-S01602DSR35480	<p>CONFIDENTIAL INFORMATION</p> <p>THE INFORMATION CONTAINED IN THIS DOCUMENT IS THE PROPERTY OF LUMEX INC. EXCEPT AS SPECIFICALLY AUTHORIZED IN WRITING BY LUMEX INC. THE HOLDER OF THIS DOCUMENT SHALL KEEP ALL INFORMATION CONTAINED HEREIN CONFIDENTIAL AND SHALL PROTECT SAME IN WHOLE OR IN PART FROM DISCLOSURE AND DISSEMINATION TO ALL THIRD PARTIES.</p> <p>RELIABILITY NOTE</p> <p>OUR MANY YEARS OF EXPERIENCE DATA ACCUMULATION INDICATE THAT SOLDER HEAT IS A MAJOR CAUSE OF EARLY AND FUTURE FAILURE. PLEASE PAY ATTENTION TO YOUR SOLDERING PROCESS.</p>	 <p>290 E. HELEN ROAD PALATINE, IL 60067-6976 PHONE: +1.847.359.2790 US WEB: www.lumex.com TW WEB: www.lumex.com.tw</p>
<p>STN, REFLECTIVE, MILL MAX HEADER, 6:00 VIEW, 5.56mm CHARACTER HEIGHT, 5 x 8 DOT MATRIX, 16 x 2 LCD MODULE, 1/16 DUTY, 1/5 BIAS.</p>		<p>DRAWN BY: JD</p>	<p>CHECKED BY:</p> <p>APPROVED BY:</p> <p>DATE: 09.26.06 PAGE: 2 OF 2 SCALE: N/A</p>