

- Designed to comply with the requirements of GR1089, UL1950, EN60950, BABT and CSA950 to provide a supplementary insulation barrier with a working voltage of 250V
- UL File Number E150991
- Minimum interwinding breakdown voltage of 1500 Vrms
- Operating and storage temperature range: -40° to +85° C
- Meets IEC 695, 2-2 flammability requirements
- PWB Process Capability: standard printed wiring board assembly techniques, total-immersion cleaning
- Reliability testing: shock, vibration, temperature cycling, temperature - humidity - bias

**ELECTRICAL SPECIFICATIONS AT 25° C**

Part Number	Turns Ratio ±2%	Inductance <sup>1</sup> mH ±5%	Leakage Inductance <sup>2</sup> µH max	DCR Ω max		Longitudinal Balance dB min	Insertion Loss dB max	Harmonic Distortion <sup>3</sup> dB max
	Chip : Line	Line Side	Line Side	Chip Side	Line Side	100 kHz - 300 kHz	100 kHz	5 kHz Fundamental
0560-6600-CK	1 : 5.4	3	15	0.40	2.96	55	0.7	-75

All measurements are made with pins 2 and 5 connected

1. Inductance measured at 10 kHz, 0.1 Vac, 100 mA DC

2. Measured at 100 kHz, 0.1 Vac

3. Measurements made with 100Ω source and 4.6Ω load impedance, 2 Vrms

**SCHEMATIC**

**0560-6600-CK**

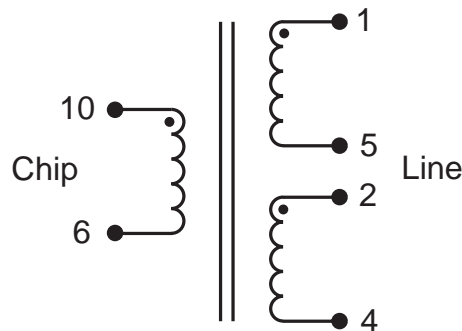

TM01375

### MECHANICAL

0560-6600-CK

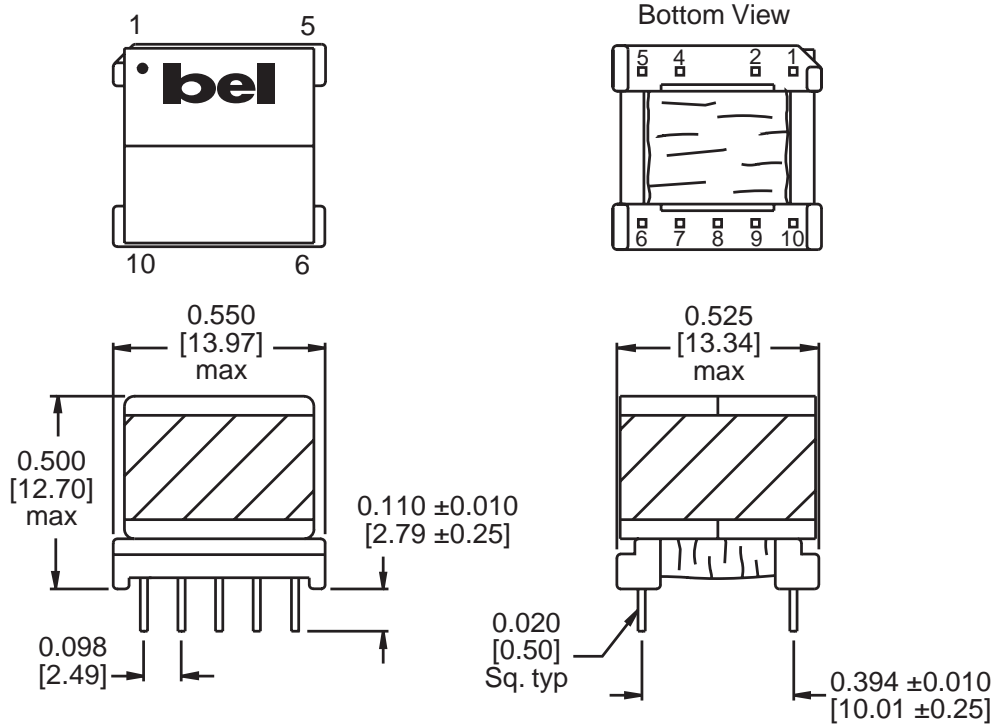

Dimensions are in inches [millimeters].  
Standard dimension tolerance is  $\pm 0.005$  [0.13] unless otherwise noted.

©2001 Bel Fuse Inc. Specifications subject to change without notice. 09.01

#### CORPORATE

**Bel Fuse Inc.**  
206 Van Vorst Street  
Jersey City, NJ 07302  
Tel 201-432-0463  
Fax 201-432-9542  
www.belfuse.com

page 2

#### FAR EAST

**Bel Fuse Ltd.**  
8F / 8 Luk Hop Street  
San Po Kong  
Kowloon, Hong Kong  
Tel 852-2328-5515  
Fax 852-2352-3706  
www.belfuse.com

#### EUROPE

**Bel Fuse Europe Ltd.**  
Preston Technology Management Centre  
Marsh Lane, Suite G7, Preston  
Lancashire, PR1 8UD, U.K.  
Tel 44-1772-556601  
Fax 44-1772-888366  
www.belfuse.com