



TDA2320

PREAMPLIFIER FOR INFRARED REMOTE CONTROL SYSTEMS

NOT FOR NEW DESIGN

- WIDE SUPPLY VOLTAGE RANGE: 4 TO 20V
- SINGLE OR SPLIT SUPPLY OPERATION
- VERY LOW CURRENT CONSUMPTION:
0.8mA
- VERY LOW DISTORTION: 0.03% TYPICA

DESCRIPTION

The TDA2320 is a monolithic integrated circuit in Dip package especially designed to amplify the IR signal in remote controlled TV or radio sets. It directly interfaces the digital control circuitry.

The TDA2320 incorporates a two-stage amplifier with excellent sensitivity and high noise immunity. It can work with a single 5V supply voltage and flash or carrier transmission modes as provided for example by the M709A/M710A/MOS transmitters.

The TDA2320 is particularly intended to be used in conjunction with the M104 and M206 + M3870 remote control receivers.

ORDER CODE

Part Number	Temperature Range	Package	
		N	D
TDA2320	-40°C, +105°C	•	•
Example : TDA2320N			

N = Dual in Line Package (DIP)

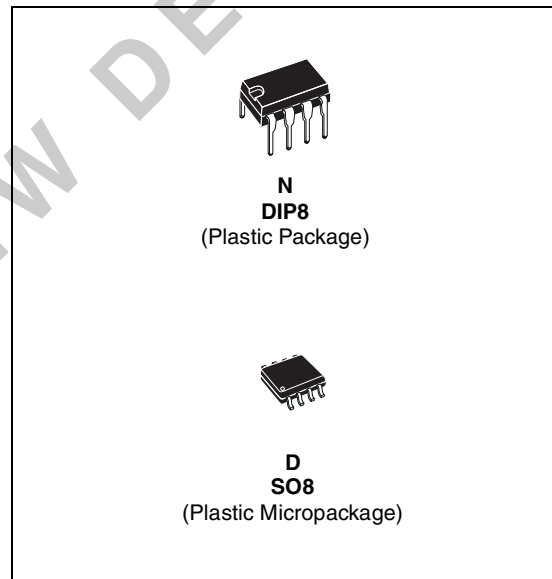

PIN CONNECTIONS (top view)

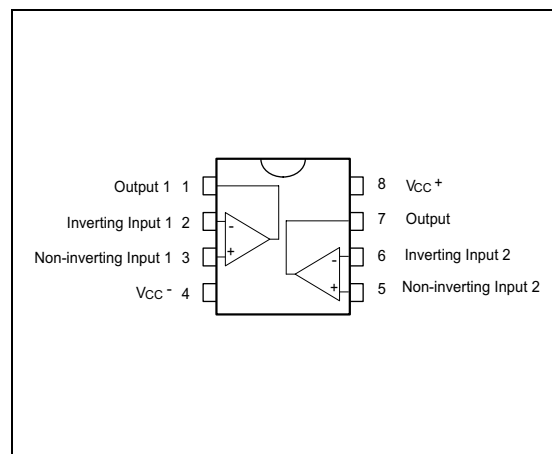

SCHMATIC DIAGRAM (1/2 TDA2320)

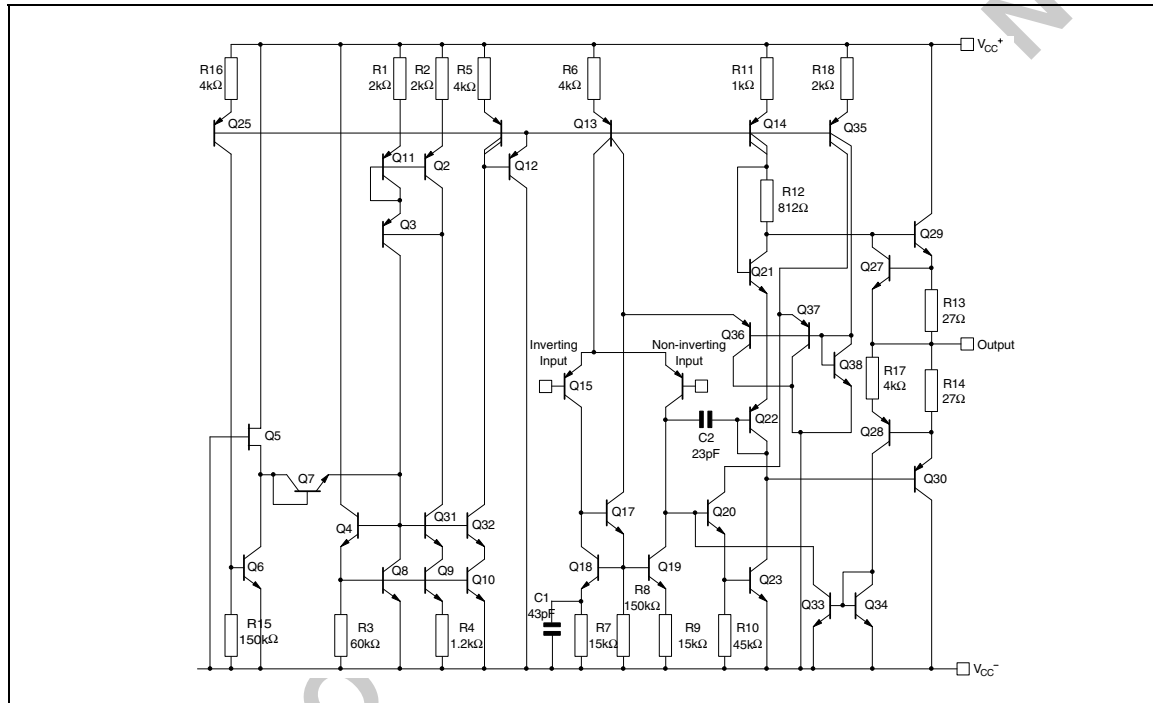

ABSOLUTE MAXIMUM RATINGS

Symbol	Parameter	Value	Unit
V_{CC}	Supply Voltage	20	V
P_{tot}	Total Power Dissipation at $T_{amb} = 70^{\circ}C$ ¹⁾	400	mW
T_{stg}, T_j	Storage and Junction Temperature	-40 to 150	$^{\circ}C$

1. Power dissipation must be considered to ensure maximum junction temperature (T_j) is not exceeded.

ELECTRICAL CHARACTERISTICS $V_{CC} = 5V$, $T_{amb} = 25^{\circ}C$ (unless otherwise specified)

Symbol	Parameter	Min.	Typ.	Max.	Unit
V_{CC}	Supply Voltage	4		20	V
I_{CC}	Supply Current $V_{CC} = 20V$		0.8	2	mA
I_{ib}	Input Bias Current		100	500	nA
V_{io}	Input Offset Voltage $R_s \leq 10k\Omega$		0.5		mV
I_{io}	Input Offset Current		15		nA
A_{vd}	Large Signal Voltage Gain $f = 1kHz$ $f = 100kHz$	64	70 30		dB
V_{opp}	DC Output Voltage Swing		2.5		V
GBP	Gain-bandwidth Product $f = 200kHz$	1.5	3		MHz
SR	Slew Rate $R_L = 2k\Omega$		1.5		V/ μ s
e_n	Equivalent Input Noise Voltage $f = 40kHz$ $R_s = 10k\Omega$		20		$\frac{nV}{\sqrt{Hz}}$
PSRR	Power Supply Rejection Ratio $f = 100Hz$		80		dB

Figure 1 : Supply Current versus Supply Voltage

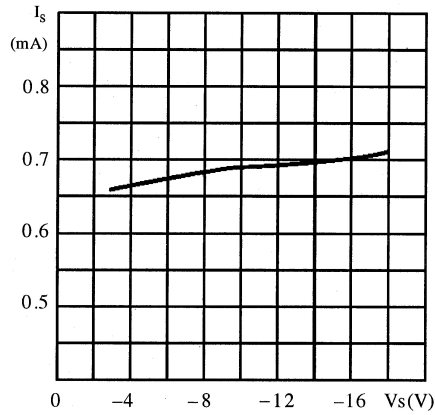

Figure 2 : Supply Current versus Ambient Temperature

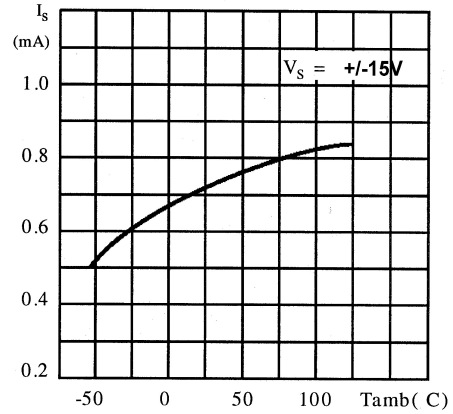

Figure 3 : Output Short Circuit Current versus Ambient Temperature

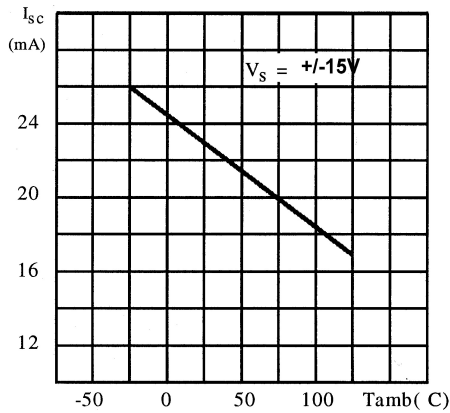

Figure 4 : Open Loop Frequency and Phase Response

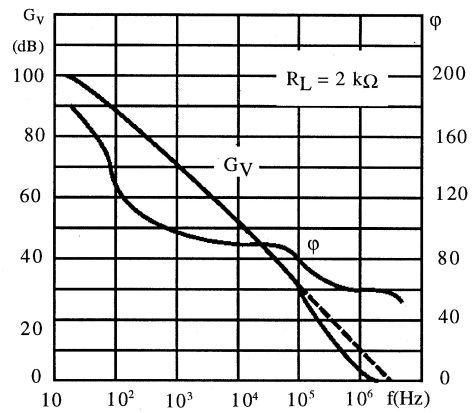

Figure 5 : Output Loop Gain versus Ambient Temperature

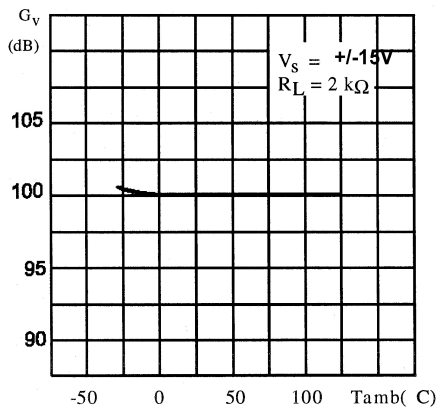

Figure 6 : Supply Voltage Rejection versus Frequency

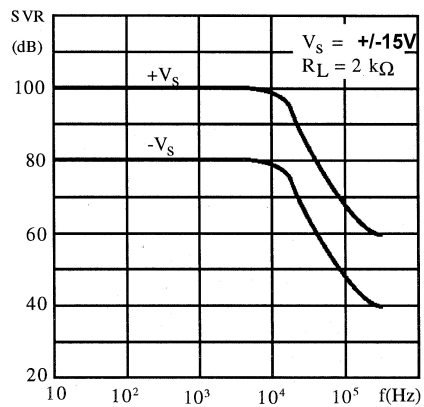

Figure 7 : Large Signal Frequency Response

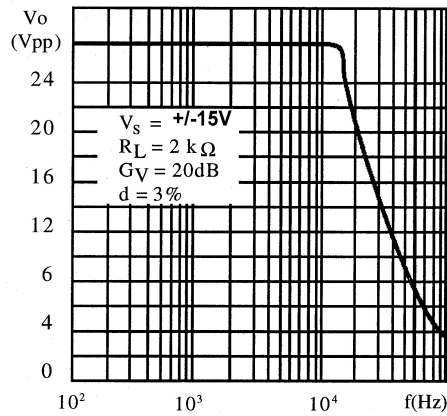

Figure 8 : Output Voltage Swing versus Load Resistance

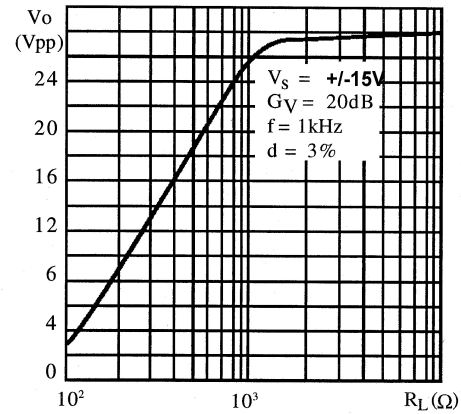

Figure 9 : Total Input Noise versus Frequency

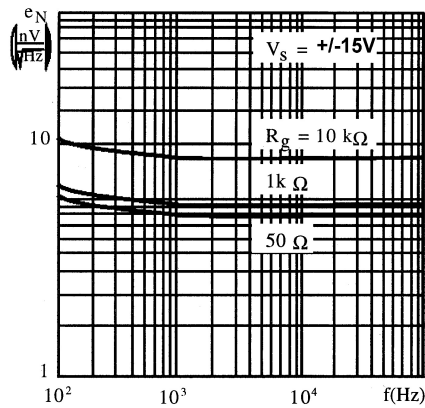

Figure 10 : Amplitude Response

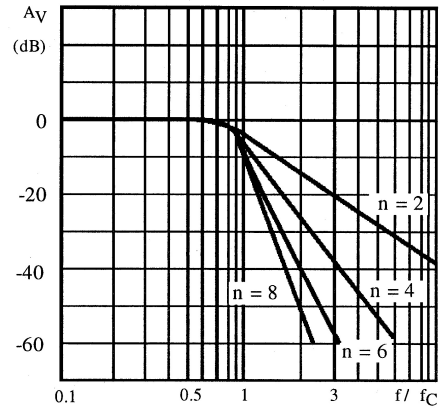

Figure 11 : Amplitude Response ($\pm 1dB$ ripple)

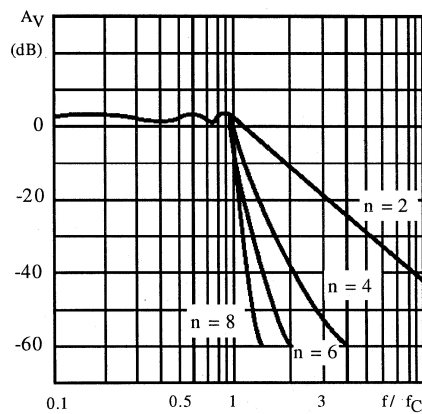

Figure 12 : Filter Configuration

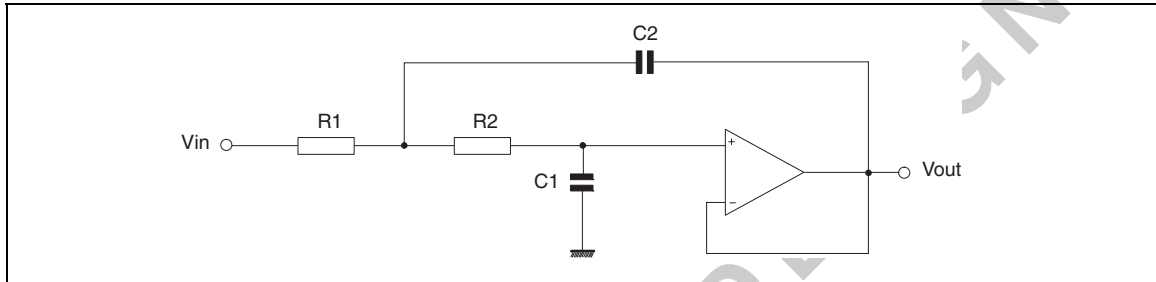

Figure 13 : 5th Order Low-pass Filter (Butterworth) with Unity Gain configuration

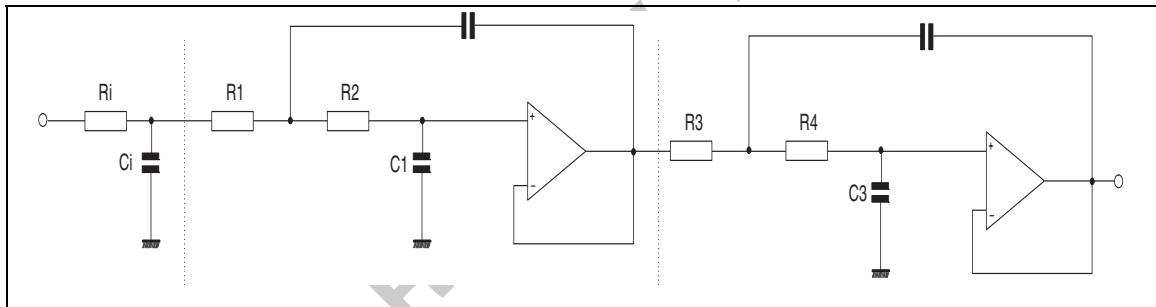
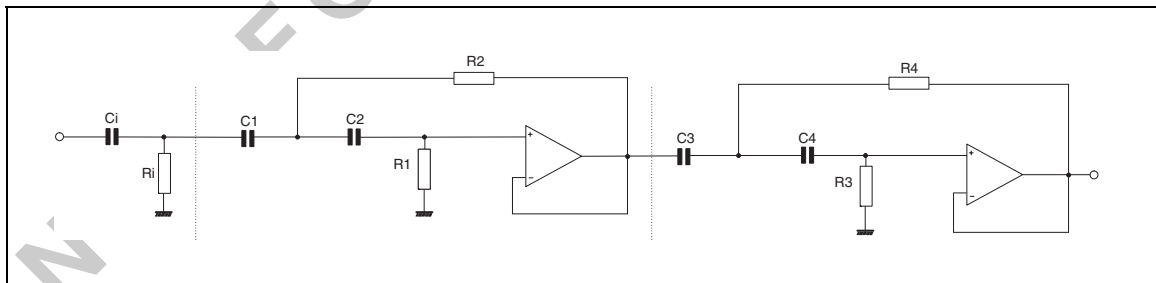

Figure 14 : 5th Order High-pass Filter (Butterworth) with Unity Gain configuration



PACKAGE MECHANICAL DATA

Plastic DIP-8 MECHANICAL DATA

DIM.	mm.			inch		
	MIN.	TYP	MAX.	MIN.	TYP.	MAX.
A		3.3			0.130	
a1	0.7			0.028		
B	1.39		1.65	0.055		0.065
B1	0.91		1.04	0.036		0.041
b		0.5			0.020	
b1	0.38		0.5	0.015		0.020
D			9.8			0.386
E		8.8			0.346	
e		2.54			0.100	
e3		7.62			0.300	
e4		7.62			0.300	
F			7.1			0.280
I			4.8			0.189
L		3.3			0.130	
Z	0.44		1.6	0.017		0.063

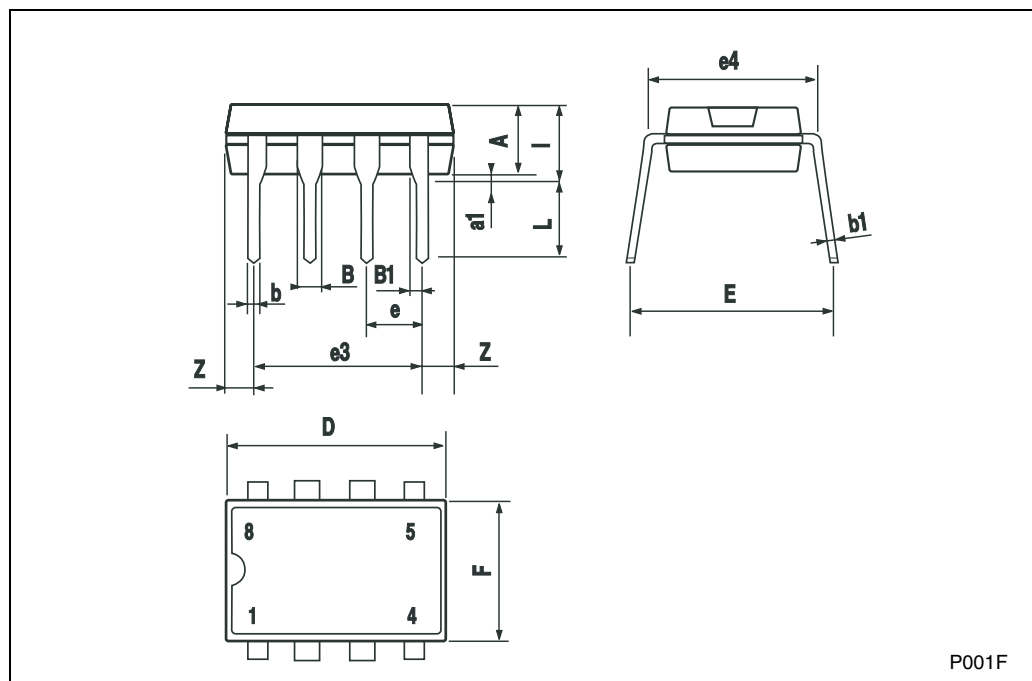

P001F

PACKAGE MECHANICAL DATA

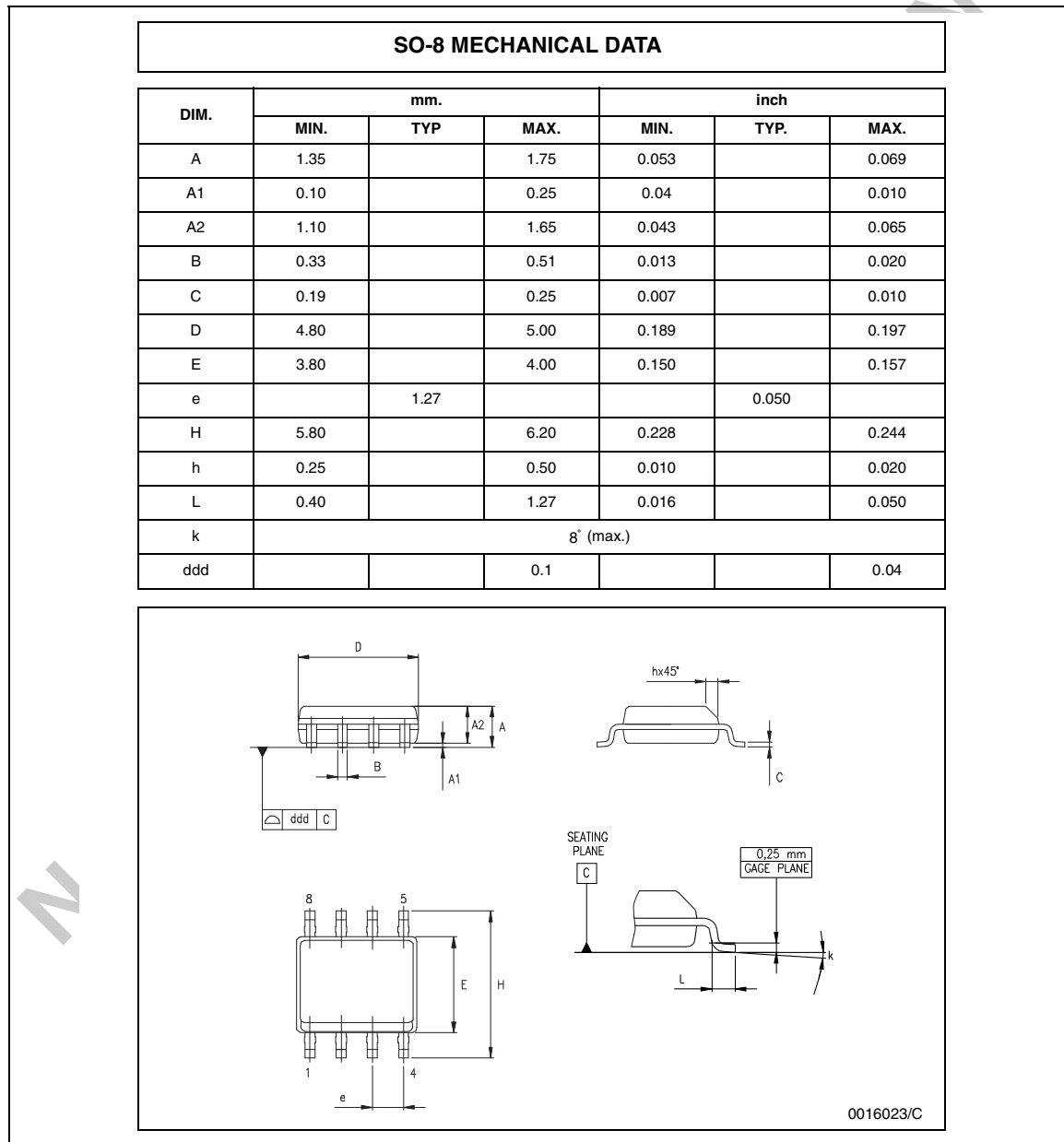

Information furnished is believed to be accurate and reliable. However, STMicroelectronics assumes no responsibility for the consequences of use of such information nor for any infringement of patents or other rights of third parties which may result from its use. No license is granted by implication or otherwise under any patent or patent rights of STMicroelectronics. Specifications mentioned in this publication are subject to change without notice. This publication supersedes and replaces all information previously supplied. STMicroelectronics products are not authorized for use as critical components in life support devices or systems without express written approval of STMicroelectronics.

The ST logo is a registered trademark of STMicroelectronics
 All other names are the property of their respective owners

© 2005 STMicroelectronics - All rights reserved

STMicroelectronics group of companies
 Australia - Belgium - Brazil - Canada - China - Czech Republic - Finland - France - Germany - Hong Kong - India - Israel - Italy - Japan - Malaysia - Malta - Morocco - Singapore - Spain - Sweden - Switzerland - United Kingdom - United States of America
www.st.com

