

Insulator: PBT+30% Glass Fiber,
 UL94V-0 Rate
 Shell: Cold Rolled Steel, Tin Plated

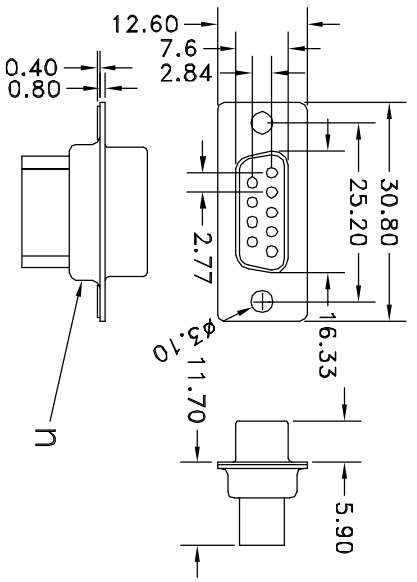

Dimension of Crimp Type Connector

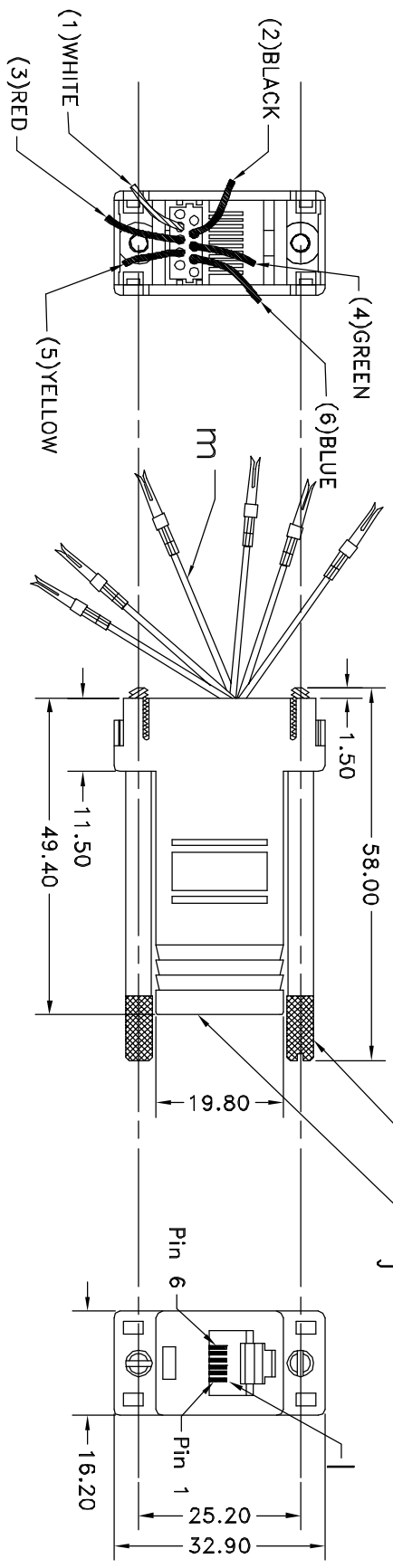

Specification:

1. Plastic Housing: ABS, Gray
2. Jackscrew: Nickel Plated, #4-40 UNC TYP.2
3. Contact: Phosphor Bronze, Gold Plated
4. Wire Lead: AWG26, Crimping Female Terminal
5. DB09 Connector: Female, Crimp Type



908 Canada Court, City of Industry, CA 91748
 TEL: (626) 964-7873
 FAX: (626) 964-7880

SCALE:	DRAWN BY: ANDY
DATE : 09/26/06	REVISED

DESCRIPTION:	Modular Jack to DB-9 6 Conduct, Female
--------------	---

PART NO:	DEM-25F	DRAWING NO:	DEM-25F.DWG
----------	---------	-------------	-------------