

# RF INDUCTORS - SURFACE MOUNT



## SML0805 Thin Film RF Inductors



PART NUMBER	L nH	TOL.	Q TYP.	TEST FREQ. MHz	SRF MHz TYP.	DCR OHMS TYP.	CURRENT RATING DC mA TYP.	MARKING
SML0805-0010	1.0	± .2nH	24	500	13000	.03	900	1.0
SML0805-0012	1.2	± .2nH	24	500	13000	.04	900	1.2
SML0805-0015	1.5	± .2nH	24	500	10000	.05	900	1.5
SML0805-0018	1.8	± .2nH	28	500	9000	.06	900	1.8
SML0805-0022	2.2	± .2nH	28	500	8000	.07	800	2.2
SML0805-0027	2.7	± .2nH	28	500	8000	.09	800	2.7
SML0805-0033	3.3	± .2nH	28	500	6000	.10	800	3.3
SML0805-0039	3.9	± .2nH	29	500	6000	.12	800	3.9
SML0805-0047	4.7	± .2nH	30	500	5000	.16	700	4.7
SML0805-0056J	5.6	± 5%	30	500	4500	.18	700	5.6
SML0805-0068J	6.8	± 5%	30	500	4000	.26	500	6.8
SML0805-0082J	8.2	± 5%	30	500	3000	.28	500	8.2
SML0805-0100J	10.0	± 5%	32	500	2750	.36	450	10
SML0805-0120J	12.0	± 5%	30	500	2500	.38	450	12
SML0805-0150J	15.0	± 5%	28	500	2250	.40	400	15
SML0805-0180J	18.0	± 5%	22	500	1600	1.00	300	18
SML0805-0220J	22.0	± 5%	22	500	1450	1.10	300	22
SML0805-0270J	27.0	± 5%	15	200	1350	1.20	300	27
SML0805-0330J	33.0	± 5%	17	200	1200	1.30	300	33
SML0805-0390J	39.0	± 5%	17	200	1000	1.40	250	39
SML0805-0470J	47.0	± 5%	17	200	950	1.50	250	47
SML0805-0560J	56.0	± 5%	15	200	800	3.50	150	56
SML0805-0680J	68.0	± 5%	15	200	700	3.50	150	68
SML0805-0820J	82.0	± 5%	15	200	600	4.00	150	82

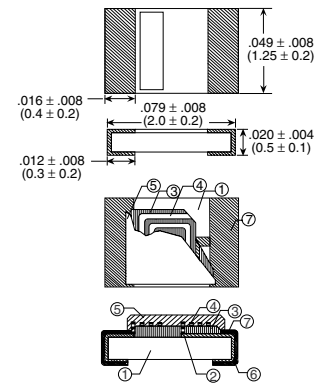

in. (mm)

① Alumina Ceramic Substrate	⑥ Cross Conductor	⑦ Polimide Insulator
② Cu Plating Coil Pattern	⑦ Epoxy Passivation	⑧ Ni Barrier
③ Solder Coating		

### NOTES:

- Operating temperature -40°C to +125°C

### TAPE AND REEL SPECS:

Pcs./Reel maximum:	4000
Pitch between parts:	4 mm
Tape width:	8 mm
Reel diameter inches:	7