

A2003, A2004, A2023, and A2024

High Voltage High Current Darlington Arrays

Discontinued Product

These parts are no longer in production. The device should not be purchased for new design applications. Samples are no longer available.

Date of status change: October 31, 2005

Recommended Substitutions:

NOTE: For detailed information on purchasing options, contact your local Allegro field applications engineer or sales representative.

Allegro MicroSystems, Inc. reserves the right to make, from time to time, revisions to the anticipated product life cycle plan for a product to accommodate changes in production capabilities, alternative product availabilities, or market demand. The information included herein is believed to be accurate and reliable. However, Allegro MicroSystems, Inc. assumes no responsibility for its use; nor for any infringements of patents or other rights of third parties which may result from its use.



2003 THRU 2024

Data Sheet
29304F

HIGH-VOLTAGE, HIGH-CURRENT DARLINGTON ARRAYS

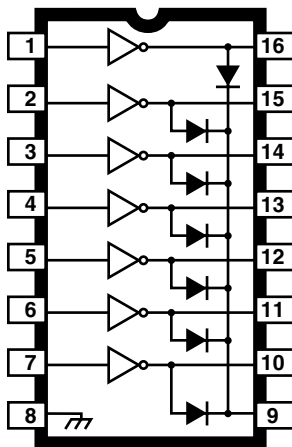

Dwg. No. A-9594

Note that the ULN20xxA series (dual in-line package) and ULN20xxL series (small-outline IC package) are electrically identical and share a common terminal number assignment.

ABSOLUTE MAXIMUM RATINGS

Output Voltage, V_{CE}	
(ULN200xA and ULN200xL)	50 V
(ULN202xA and ULN202xL)	95 V
Input Voltage, V_{IN}	30 V
Continuous Output Current,	
I_C	500 mA
Continuous Input Current, I_{IN}	25 mA
Power Dissipation, P_D	
(one Darlington pair)	1.0 W
(total package)	See Graph
Operating Temperature Range,	
T_A	-20°C to +85°C
Storage Temperature Range,	
T_S	-55°C to +150°C

Ideally suited for interfacing between low-level logic circuitry and multiple peripheral power loads, the Series ULN20xxA/L high-voltage, high-current Darlington arrays feature continuous load current ratings to 500 mA for each of the seven drivers. At an appropriate duty cycle depending on ambient temperature and number of drivers turned ON simultaneously, typical power loads totaling over 230 W (350 mA x 7, 95 V) can be controlled. Typical loads include relays, solenoids, stepping motors, magnetic print hammers, multiplexed LED and incandescent displays, and heaters. All devices feature open-collector outputs with integral clamp diodes.

The ULN2003A/L and ULN2023A/L have series input resistors selected for operation directly with 5 V TTL or CMOS. These devices will handle numerous interface needs — particularly those beyond the capabilities of standard logic buffers.

The ULN2004A/L and ULN2024A/L have series input resistors for operation directly from 6 to 15 V CMOS or PMOS logic outputs.

The ULN2003A/L and ULN2004A/L are the standard Darlington arrays. The outputs are capable of sinking 500 mA and will withstand at least 50 V in the OFF state. Outputs may be paralleled for higher load current capability. The ULN2023A/L and ULN2024A/L will withstand 95 V in the OFF state.

These Darlington arrays are furnished in 16-pin dual in-line plastic packages (suffix “A”) and 16-lead surface-mountable SOICs (suffix “L”). All devices are pinned with outputs opposite inputs to facilitate ease of circuit board layout. All devices are rated for operation over the temperature range of -20°C to +85°C. Most (see matrix, next page) are also available for operation to -40°C; to order, change the prefix from “ULN” to “ULQ”.

FEATURES

- TTL, DTL, PMOS, or CMOS-Compatible Inputs
- Output Current to 500 mA
- Output Voltage to 95 V
- Transient-Protected Outputs
- Dual In-Line Plastic Package or Small-Outline IC Package

x = digit to identify specific device. Characteristic shown applies to family of devices with remaining digits as shown. See matrix on next page.



**2003 THRU 2024
HIGH-VOLTAGE,
HIGH-CURRENT
DARLINGTON ARRAYS**

DEVICE PART NUMBER DESIGNATION

$V_{CE(MAX)}$	50 V	95 V
$I_{C(MAX)}$	500 mA	500 mA
Logic	Part Number	
5V TTL, CMOS	ULN2003A* ULN2003L*	ULN2023A* ULN2023L
6-15 V CMOS, PMOS	ULN2004A* ULN2004L*	ULN2024A ULN2024L

* Also available for operation between -40°C and +85°C. To order, change prefix from "ULN" to "ULQ".

PARTIAL SCHEMATICS

ULN20x3A/L (Each Driver)

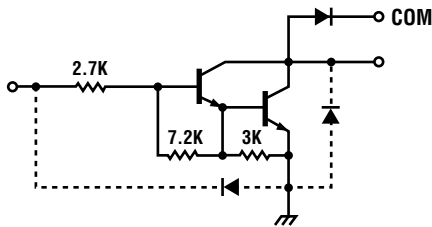

Dwg. No. A-9651

ULN20x4A/L (Each Driver)

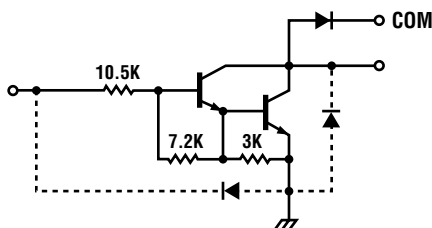

Dwg. No. A-9898A

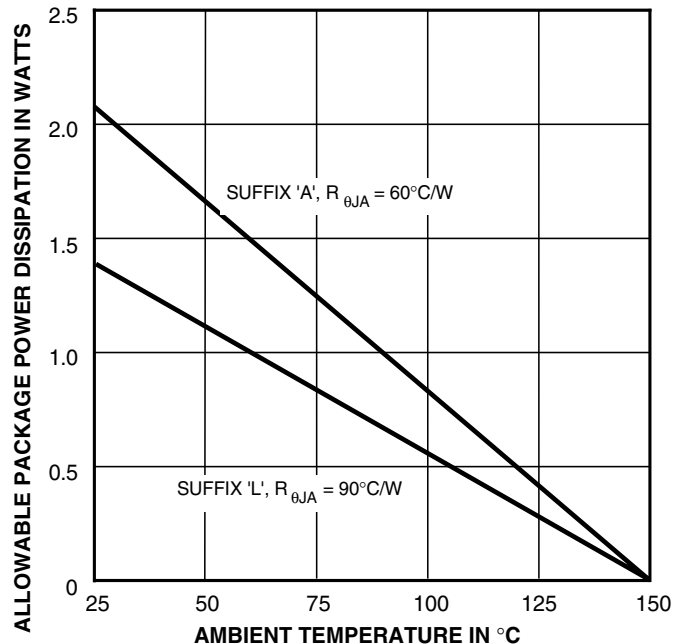

Dwg. GP-006A

X = Digit to identify specific device. Specification shown applies to family of devices with remaining digits as shown. See matrix above.



115 Northeast Cutoff, Box 15036
Worcester, Massachusetts 01615-0036 (508) 853-5000
Copyright © 1974, 1998 Allegro MicroSystems, Inc.

2003 THRU 2024
HIGH-VOLTAGE,
HIGH-CURRENT
DARLINGTON ARRAYS

Types ULN2003A, ULN2003L, ULN2004A, and ULN2004L
ELECTRICAL CHARACTERISTICS at +25°C (unless otherwise noted).

Characteristic	Symbol	Test Fig.	Applicable Devices	Test Conditions	Limits			
					Min.	Typ.	Max.	Units
Output Leakage Current	I_{CEX}	1A	All	$V_{CE} = 50\text{ V}, T_A = 25^\circ\text{C}$	—	< 1	50	μA
				$V_{CE} = 50\text{ V}, T_A = 70^\circ\text{C}$	—	< 1	100	μA
		1B	ULN2004A/L	$V_{CE} = 50\text{ V}, T_A = 70^\circ\text{C}, V_{IN} = 1.0\text{ V}$	—	< 5	500	μA
Collector-Emitter Saturation Voltage	$V_{CE(SAT)}$	2	All	$I_C = 100\text{ mA}, I_B = 250\text{ }\mu\text{A}$	—	0.9	1.1	V
				$I_C = 200\text{ mA}, I_B = 350\text{ }\mu\text{A}$	—	1.1	1.3	V
				$I_C = 350\text{ mA}, I_B = 500\text{ }\mu\text{A}$	—	1.3	1.6	V
Input Current	$I_{IN(ON)}$	3	ULN2003A/L	$V_{IN} = 3.85\text{ V}$	—	0.93	1.35	mA
			ULN2004A/L	$V_{IN} = 5.0\text{ V}$	—	0.35	0.5	mA
				$V_{IN} = 12\text{ V}$	—	1.0	1.45	mA
	$I_{IN(OFF)}$	4	All	$I_C = 500\text{ }\mu\text{A}, T_A = 70^\circ\text{C}$	50	65	—	μA
Input Voltage	$V_{IN(ON)}$	5	ULN2003A/L	$V_{CE} = 2.0\text{ V}, I_C = 200\text{ mA}$	—	—	2.4	V
				$V_{CE} = 2.0\text{ V}, I_C = 250\text{ mA}$	—	—	2.7	V
				$V_{CE} = 2.0\text{ V}, I_C = 300\text{ mA}$	—	—	3.0	V
		ULN2004A/L	$V_{CE} = 2.0\text{ V}, I_C = 125\text{ mA}$	—	—	5.0	V	
			$V_{CE} = 2.0\text{ V}, I_C = 200\text{ mA}$	—	—	6.0	V	
			$V_{CE} = 2.0\text{ V}, I_C = 275\text{ mA}$	—	—	7.0	V	
			$V_{CE} = 2.0\text{ V}, I_C = 350\text{ mA}$	—	—	8.0	V	
Input Capacitance	C_{IN}	—	All		—	15	25	pF
Turn-On Delay	t_{PLH}	8	All	$0.5 E_{IN}$ to $0.5 E_{OUT}$	—	0.25	1.0	μs
Turn-Off Delay	t_{PHL}	8	All	$0.5 E_{IN}$ to $0.5 E_{OUT}$	—	0.25	1.0	μs
Clamp Diode Leakage Current	I_R	6	All	$V_R = 50\text{ V}, T_A = 25^\circ\text{C}$	—	—	50	μA
				$V_R = 50\text{ V}, T_A = 70^\circ\text{C}$	—	—	100	μA
Clamp Diode Forward Voltage	V_F	7	All	$I_F = 350\text{ mA}$	—	1.7	2.0	V

Complete part number includes suffix to identify package style: A = DIP, L = SOIC.

2003 THRU 2024
HIGH-VOLTAGE,
HIGH-CURRENT
DARLINGTON ARRAYS

Types ULN2023A, ULN2023L, ULN2024A, and ULN2024L
ELECTRICAL CHARACTERISTICS at +25°C (unless otherwise noted).

Characteristic	Symbol	Test Fig.	Applicable Devices	Test Conditions	Limits			
					Min.	Typ.	Max.	Units
Output Leakage Current	I_{CEX}	1A	All	$V_{CE} = 95\text{ V}, T_A = 25^\circ\text{C}$	—	< 1	50	μA
				$V_{CE} = 95\text{ V}, T_A = 70^\circ\text{C}$	—	< 1	100	μA
		1B	ULN2024A/L	$V_{CE} = 95\text{ V}, T_A = 70^\circ\text{C}, V_{IN} = 1.0\text{ V}$	—	< 5	500	μA
Collector-Emitter Saturation Voltage	$V_{CE(SAT)}$	2	All	$I_C = 100\text{ mA}, I_B = 250\text{ }\mu\text{A}$	—	0.9	1.1	V
				$I_C = 200\text{ mA}, I_B = 350\text{ }\mu\text{A}$	—	1.1	1.3	V
				$I_C = 350\text{ mA}, I_B = 500\text{ }\mu\text{A}$	—	1.3	1.6	V
Input Current	$I_{IN(ON)}$	3	ULN2023A/L	$V_{IN} = 3.85\text{ V}$	—	0.93	1.35	mA
			ULN2024A/L	$V_{IN} = 5.0\text{ V}$	—	0.35	0.5	mA
				$V_{IN} = 12\text{ V}$	—	1.0	1.45	mA
	$I_{IN(OFF)}$	4	All	$I_C = 500\text{ }\mu\text{A}, T_A = 70^\circ\text{C}$	50	65	—	μA
Input Voltage	$V_{IN(ON)}$	5	ULN2023A/L	$V_{CE} = 2.0\text{ V}, I_C = 200\text{ mA}$	—	—	2.4	V
				$V_{CE} = 2.0\text{ V}, I_C = 250\text{ mA}$	—	—	2.7	V
				$V_{CE} = 2.0\text{ V}, I_C = 300\text{ mA}$	—	—	3.0	V
		ULN2024A/L	$V_{CE} = 2.0\text{ V}, I_C = 125\text{ mA}$	—	—	5.0	V	
			$V_{CE} = 2.0\text{ V}, I_C = 200\text{ mA}$	—	—	6.0	V	
			$V_{CE} = 2.0\text{ V}, I_C = 275\text{ mA}$	—	—	7.0	V	
			$V_{CE} = 2.0\text{ V}, I_C = 350\text{ mA}$	—	—	8.0	V	
Input Capacitance	C_{IN}	—	All		—	15	25	pF
Turn-On Delay	t_{PLH}	8	All	$0.5 E_{IN}$ to $0.5 E_{OUT}$	—	0.25	1.0	μs
Turn-Off Delay	t_{PHL}	8	All	$0.5 E_{IN}$ to $0.5 E_{OUT}$	—	0.25	1.0	μs
Clamp Diode Leakage Current	I_R	6	All	$V_R = 95\text{ V}, T_A = 25^\circ\text{C}$	—	—	50	μA
				$V_R = 95\text{ V}, T_A = 70^\circ\text{C}$	—	—	100	μA
Clamp Diode Forward Voltage	V_F	7	All	$I_F = 350\text{ mA}$	—	1.7	2.0	V

Complete part number includes suffix to identify package style: A = DIP, L = SOIC.



115 Northeast Cutoff, Box 15036
Worcester, Massachusetts 01615-0036 (508) 853-5000

2003 THRU 2024 HIGH-VOLTAGE, HIGH-CURRENT DARLINGTON ARRAYS

TEST FIGURES

FIGURE 1A

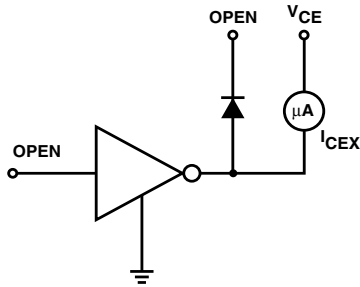

Dwg. No. A-9729A

FIGURE 1B

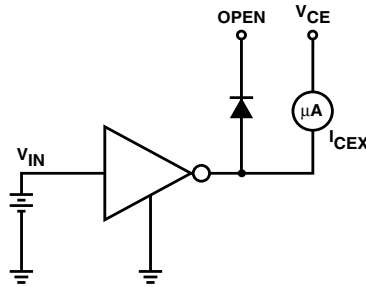

Dwg. No. A-9730A

FIGURE 2

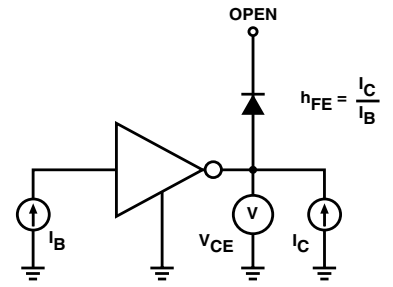

Dwg. No. A-9731A

FIGURE 3

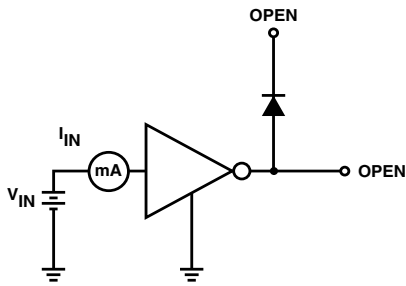

Dwg. No. A-9732A

FIGURE 4

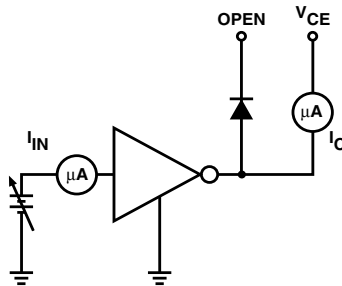

Dwg. No. A-9733A

FIGURE 5

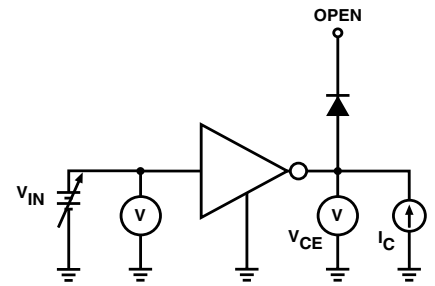

Dwg. No. A-9734A

FIGURE 6

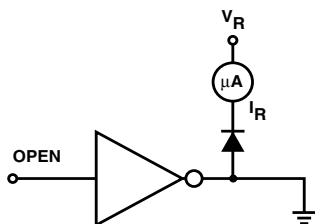

Dwg. No. A-9735A

FIGURE 7

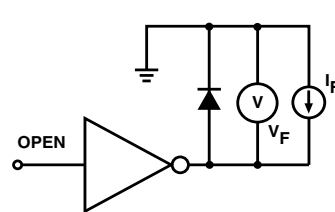

Dwg. No. A-9736A

FIGURE 8

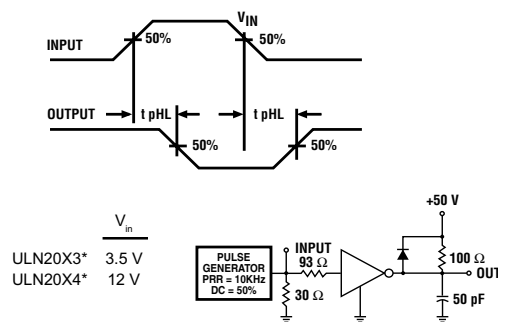

* Complete part number includes a final letter to indicate package.

X = Digit to identify specific device. Specification shown applies to family of devices with remaining digits as shown.

2003 THRU 2024 HIGH-VOLTAGE, HIGH-CURRENT DARLINGTON ARRAYS

ALLOWABLE COLLECTOR CURRENT AS A FUNCTION OF DUTY CYCLE (Dual In-line-Packaged Devices, Suffix 'A')

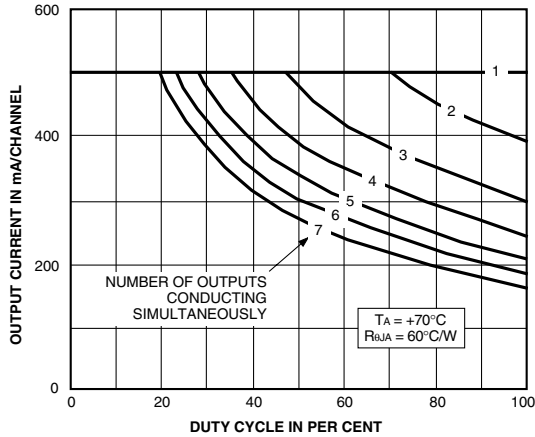

Dwg. GP-070

(Small-Outline-Packaged Devices, Suffix 'L')

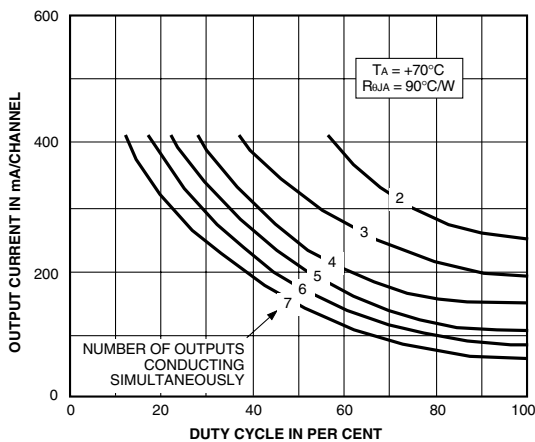

Dwg. GP-044A

TYPICAL APPLICATIONS

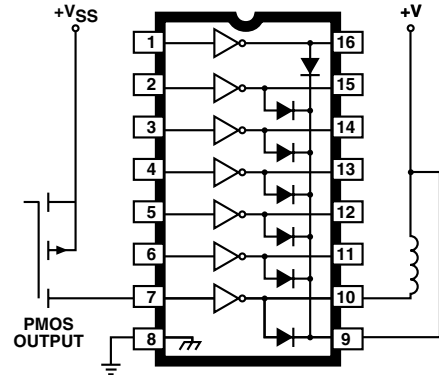

Dwg. No. A-9652

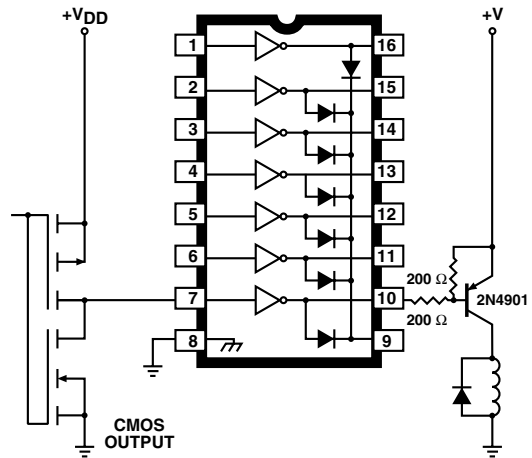

Dwg. No. A-9654A

SATURATION VOLTAGE AS A FUNCTION OF COLLECTOR CURRENT

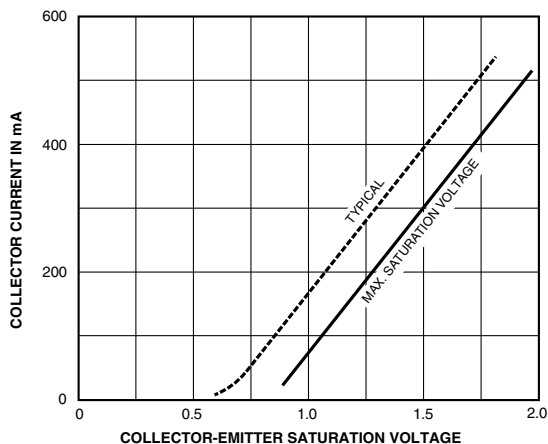

Dwg. GP-067

COLLECTOR CURRENT AS A FUNCTION OF INPUT CURRENT

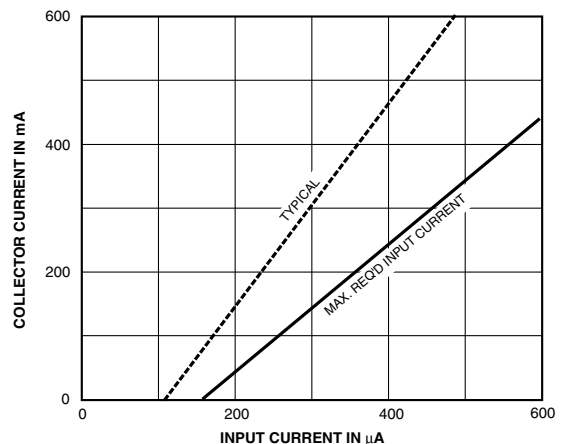

Dwg. GP-068



115 Northeast Cutoff, Box 15036
Worcester, Massachusetts 01615-0036 (508) 853-5000

2003 THRU 2024 HIGH-VOLTAGE, HIGH-CURRENT DARLINGTON ARRAYS

TYPICAL APPLICATIONS

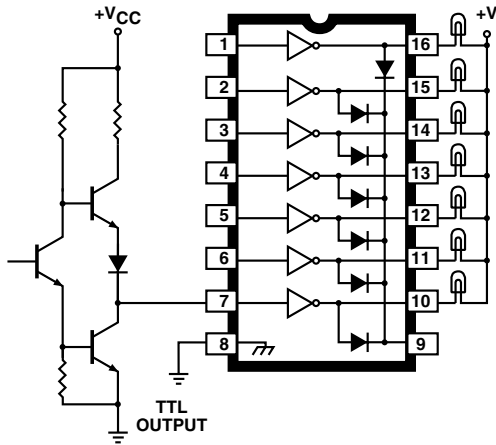

Dwg. No. A-9653A

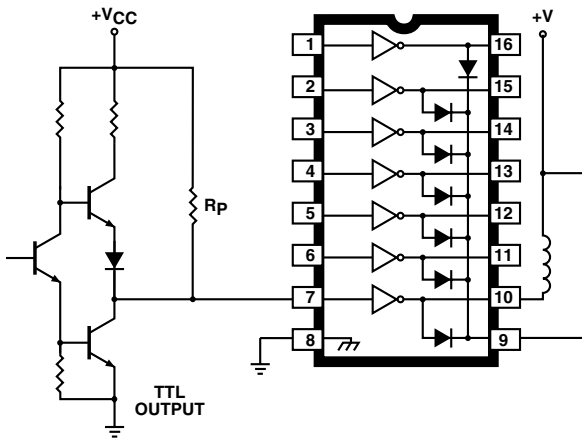

Dwg. No. A-10,175

INPUT CURRENT AS A FUNCTION OF INPUT VOLTAGE

Types ULN2003A, ULN2003L, ULN2023A, and
ULN2023L

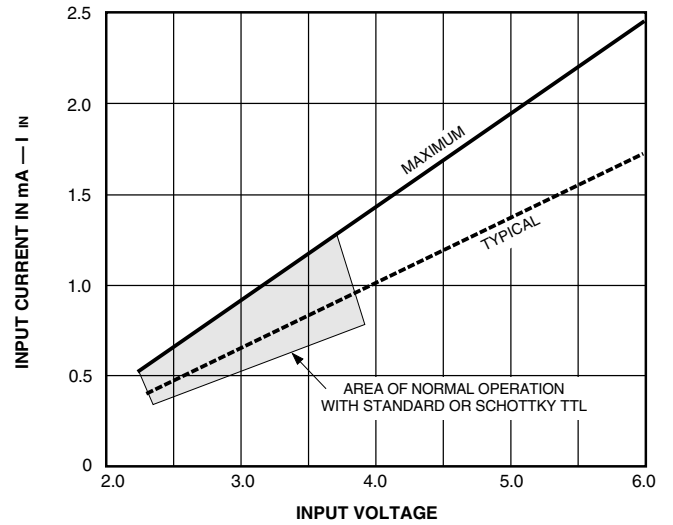

Dwg. GP-069

Types ULN2004A, ULN2004L, ULN2024A, and
ULN2024L

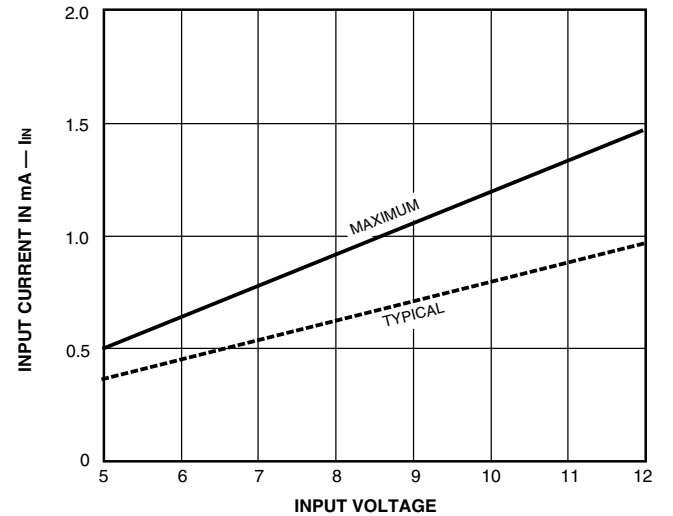

Dwg. GP-069-1

2003 THRU 2024
HIGH-VOLTAGE,
HIGH-CURRENT
DARLINGTON ARRAYS

PACKAGE DESIGNATOR "A"

Dimensions in Inches
 (controlling dimensions)

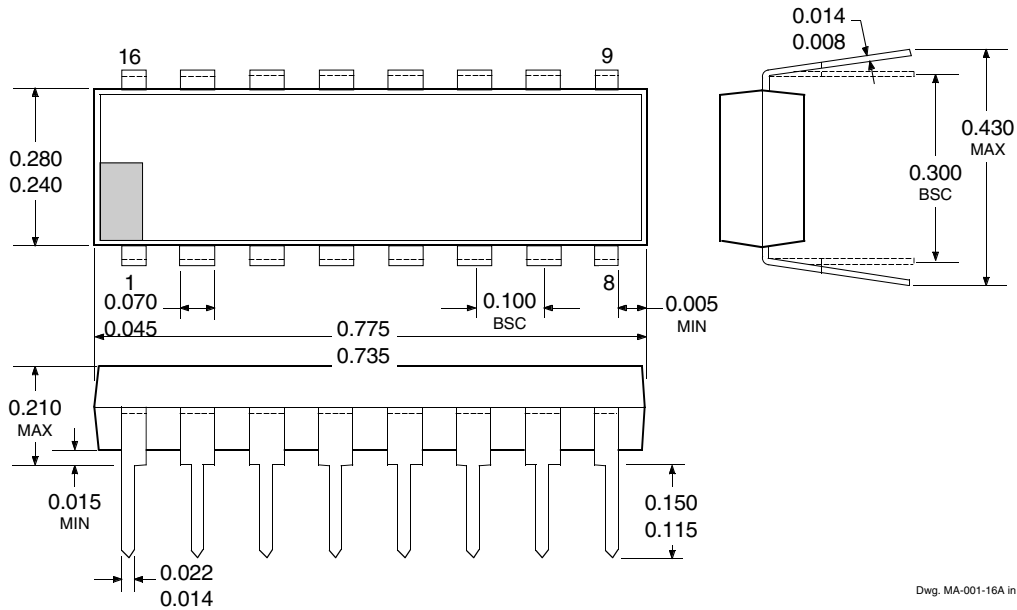

Dwg. MA-001-16A in

Dimension in Millimeters
 (for reference only)

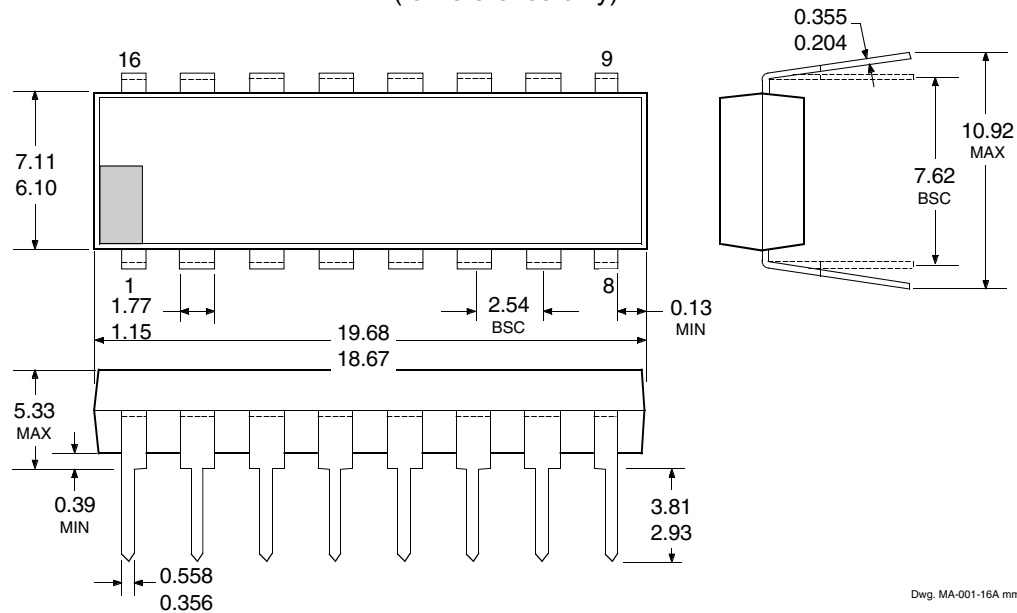

Dwg. MA-001-16A mm

- NOTES: 1. Leads 1, 8, 9, and 16 may be half leads at vendor's option.
 2. Lead thickness is measured at seating plane or below.
 3. Lead spacing tolerance is non-cumulative.
 4. Exact body and lead configuration at vendor's option within limits shown.



115 Northeast Cutoff, Box 15036
 Worcester, Massachusetts 01615-0036 (508) 853-5000

2003 THRU 2024 HIGH-VOLTAGE, HIGH-CURRENT DARLINGTON ARRAYS

PACKAGE DESIGNATOR "L"

Dimensions in Inches
(for reference only)

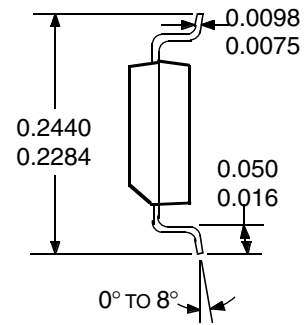
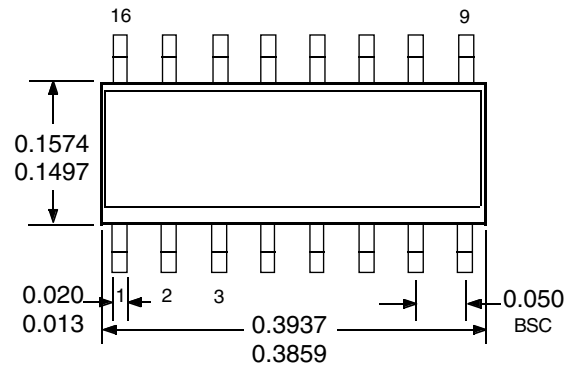

Dwg. MA-007-16 in

Dimension in Millimeters
(controlling dimensions)

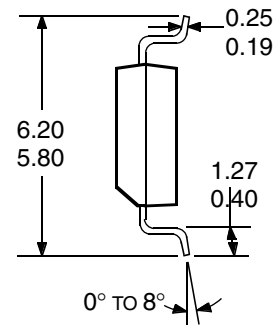
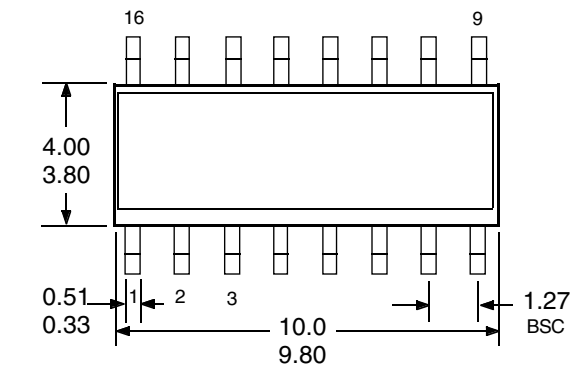

Dwg. MA-007-16A mm

- NOTES: 1. Lead spacing tolerance is non-cumulative.
2. Exact body and lead configuration at vendor's option within limits shown.

2003 THRU 2024
HIGH-VOLTAGE,
HIGH-CURRENT
DARLINGTON ARRAYS

The products described here are manufactured under one or more U.S. patents or U.S. patents pending.

Allegro MicroSystems, Inc. reserves the right to make, from time to time, such departures from the detail specifications as may be required to permit improvements in the performance, reliability, or manufacturability of its products. Before placing an order, the user is cautioned to verify that the information being relied upon is current.

Allegro products are not authorized for use as critical components in life-support devices or systems without express written approval.

The information included herein is believed to be accurate and reliable. However, Allegro MicroSystems, Inc. assumes no responsibility for its use; nor for any infringement of patents or other rights of third parties which may result from its use.



115 Northeast Cutoff, Box 15036
Worcester, Massachusetts 01615-0036 (508) 853-5000