

RAD-HARD 8 BIT EQUALITY COMPARATOR

- HIGH SPEED:
 $t_{PD} = 17\text{ns}$ (TYP.) at $V_{CC} = 6\text{V}$
- LOW POWER DISSIPATION:
 $I_{CC} = 4\mu\text{A}$ (MAX.) at $T_A=25^\circ\text{C}$
- HIGH NOISE IMMUNITY:
 $V_{NIH} = V_{NIL} = 28\% V_{CC}$ (MIN.)
- SYMMETRICAL OUTPUT IMPEDANCE:
 $|I_{OH}| = |I_{OL}| = 4\text{mA}$ (MIN)
- BALANCED PROPAGATION DELAYS:
 $t_{PLH} \cong t_{PHL}$
- WIDE OPERATING VOLTAGE RANGE:
 V_{CC} (OPR) = 2V to 6V
- PIN AND FUNCTION COMPATIBLE WITH 54 SERIES 688
- SPACE GRADE-1: ESA SCC QUALIFIED
- 50 krad QUALIFIED, 100 krad AVAILABLE ON REQUEST
- NO SEL UNDER HIGH LET HEAVY IONS IRRADIATION
- DEVICE FULLY COMPLIANT WITH SCC-9209-005

DESCRIPTION

The M54HC688 is an high speed CMOS 8 BIT EQUALITY COMPARATOR fabricated with silicon gate C²MOS technology.

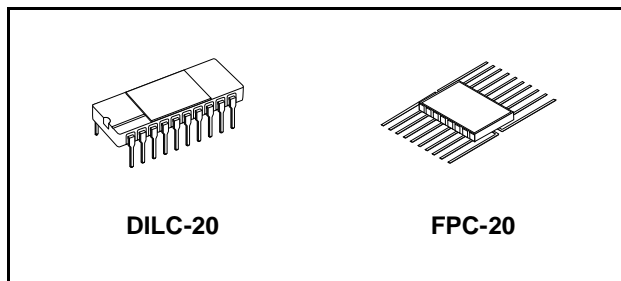

ORDER CODES

PACKAGE	FM	EM
DILC	M54HC688D	M54HC688D1
FPC	M54HC688K	M54HC688K1

The M54HC688 compares bit for bit two 8-bit words applied on inputs P0 - P7 and inputs Q0 - Q7 and indicates whether or not they are equal. A single active low enable is provided to facilitate cascading several packages to enable comparison of words greater than 8 bits. All inputs are equipped with protection circuits against static discharge and transient excess voltage.

PIN CONNECTION

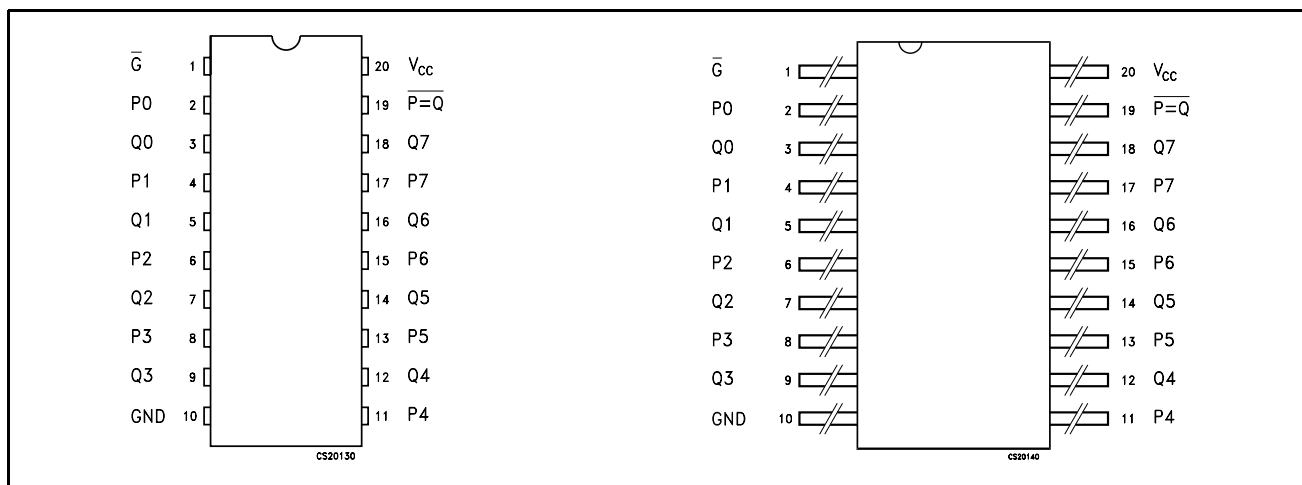

Figure 1: IEC Logic Symbols

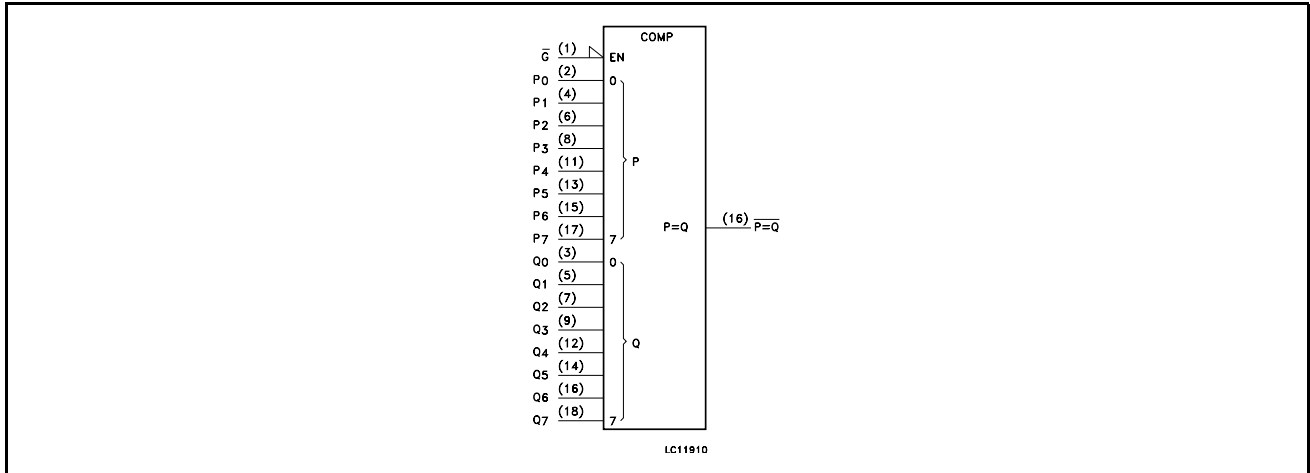

Figure 2: Input And Output Equivalent Circuit

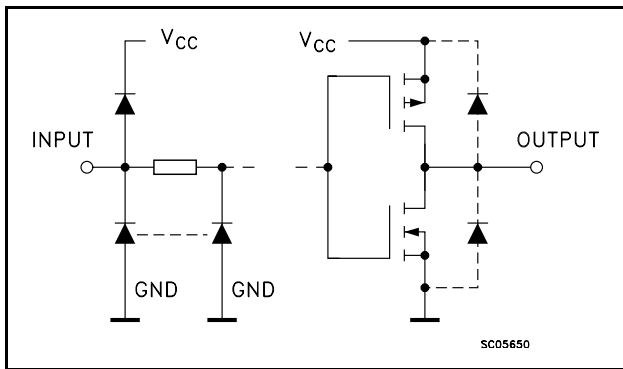

Table 1: Pin Description

PIN N°	SYMBOL	NAME AND FUNCTION
1	\overline{G}	Enable Input (Active LOW)
2, 4, 6, 8, 11, 13, 15, 17	P0 to P7	Word Inputs
3, 5, 7, 9, 12, 14, 16, 18	Q0 to Q7	Word Outputs
19	$\overline{P = Q}$	Equal to Output
10	GND	Ground (0V)
20	V _{CC}	Positive Supply Voltage

Table 2: Truth Table

INPUTS		OUTPUT
P, Q	\overline{G}	$\overline{P = Q}$
P = Q	L	L
P <> Q	L	H
X	H	H

X: Don't Care

Figure 3: Logic Diagram

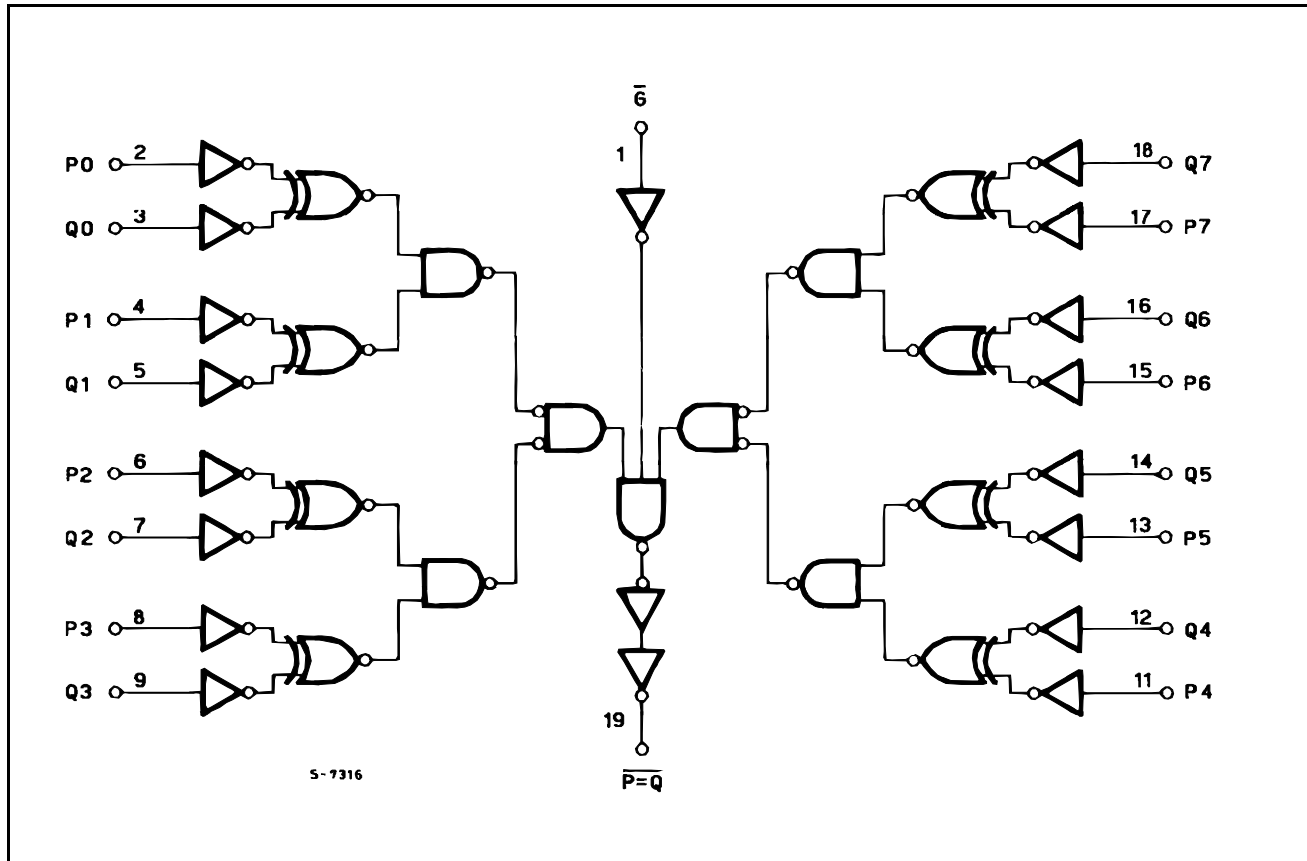

This logic diagram has not be used to estimate propagation delays

Table 3: Absolute Maximum Ratings

Symbol	Parameter	Value	Unit
V_{CC}	Supply Voltage	-0.5 to +7	V
V_I	DC Input Voltage	-0.5 to $V_{CC} + 0.5$	V
V_O	DC Output Voltage	-0.5 to $V_{CC} + 0.5$	V
I_{IK}	DC Input Diode Current	± 20	mA
I_{OK}	DC Output Diode Current	± 20	mA
I_O	DC Output Current	± 25	mA
I_{CC} or I_{GND}	DC V_{CC} or Ground Current	± 50	mA
P_D	Power Dissipation	300	mW
T_{stg}	Storage Temperature	-65 to +150	$^{\circ}C$
T_L	Lead Temperature (10 sec)	265	$^{\circ}C$

Absolute Maximum Ratings are those values beyond which damage to the device may occur. Functional operation under these conditions is not implied

Table 4: Recommended Operating Conditions

Symbol	Parameter	Value	Unit	
V_{CC}	Supply Voltage	2 to 6	V	
V_I	Input Voltage	0 to V_{CC}	V	
V_O	Output Voltage	0 to V_{CC}	V	
T_{op}	Operating Temperature	-55 to 125	°C	
t_r, t_f	Input Rise and Fall Time	$V_{CC} = 2.0V$	0 to 1000	ns
		$V_{CC} = 4.5V$	0 to 500	ns
		$V_{CC} = 6.0V$	0 to 400	ns

Table 5: DC Specifications

Symbol	Parameter	Test Condition		Value						Unit	
		V_{CC} (V)		$T_A = 25^\circ C$			-40 to 85°C		-55 to 125°C		
				Min.	Typ.	Max.	Min.	Max.	Min.		Max.
V_{IH}	High Level Input Voltage	2.0		1.5			1.5		1.5		V
		4.5		3.15			3.15		3.15		
		6.0		4.2			4.2		4.2		
V_{IL}	Low Level Input Voltage	2.0				0.5		0.5		0.5	V
		4.5				1.35		1.35		1.35	
		6.0				1.8		1.8		1.8	
V_{OH}	High Level Output Voltage	2.0	$I_O = -20 \mu A$	1.9	2.0		1.9		1.9		V
		4.5	$I_O = -20 \mu A$	4.4	4.5		4.4		4.4		
		6.0	$I_O = -20 \mu A$	5.9	6.0		5.9		5.9		
		4.5	$I_O = -4.0 mA$	4.18	4.31		4.13		4.10		
		6.0	$I_O = -5.2 mA$	5.68	5.8		5.63		5.60		
V_{OL}	Low Level Output Voltage	2.0	$I_O = 20 \mu A$		0.0	0.1		0.1		0.1	V
		4.5	$I_O = 20 \mu A$		0.0	0.1		0.1		0.1	
		6.0	$I_O = 20 \mu A$		0.0	0.1		0.1		0.1	
		4.5	$I_O = 4.0 mA$		0.17	0.26		0.33		0.40	
		6.0	$I_O = 5.2 mA$		0.18	0.26		0.33		0.40	
I_I	Input Leakage Current	6.0	$V_I = V_{CC}$ or GND			± 0.1		± 1		± 1	μA
I_{CC}	Quiescent Supply Current	6.0	$V_I = V_{CC}$ or GND			4		40		80	μA

Table 6: AC Electrical Characteristics ($C_L = 50 \text{ pF}$, Input $t_r = t_f = 6 \text{ ns}$)

Symbol	Parameter	Test Condition			Value						Unit	
		V_{CC} (V)			$T_A = 25^\circ\text{C}$			$-40 \text{ to } 85^\circ\text{C}$		$-55 \text{ to } 125^\circ\text{C}$		
					Min.	Typ.	Max.	Min.	Max.	Min.		Max.
t_{TLH} t_{THL}	Output Transition Time	2.0				30	75		95		110	ns
		4.5				8	15		19		22	
		6.0				7	13		16		19	
t_{PLH} t_{PHL}	Propagation Delay Time ($P_n, Q_n - \overline{P=Q}$)	2.0				60	170		215		255	ns
		4.5				21	34		43		51	
		6.0				17	29		37		43	
t_{PLH} t_{PHL}	Propagation Delay Time ($G - P=Q$)	2.0				40	110		140		165	ns
		4.5				13	22		28		33	
		6.0				10	19		24		28	

Table 7: Capacitive Characteristics

Symbol	Parameter	Test Condition			Value						Unit	
		V_{CC} (V)			$T_A = 25^\circ\text{C}$			$-40 \text{ to } 85^\circ\text{C}$		$-55 \text{ to } 125^\circ\text{C}$		
					Min.	Typ.	Max.	Min.	Max.	Min.		Max.
C_{IN}	Input Capacitance					5	10		10		10	pF
C_{PD}	Power Dissipation Capacitance (note 1)					32						pF

1) C_{PD} is defined as the value of the IC's internal equivalent capacitance which is calculated from the operating current consumption without load. (Refer to Test Circuit). Average operating current can be obtained by the following equation. $I_{CC(opr)} = C_{PD} \times V_{CC} \times f_{IN} + I_{CC}$

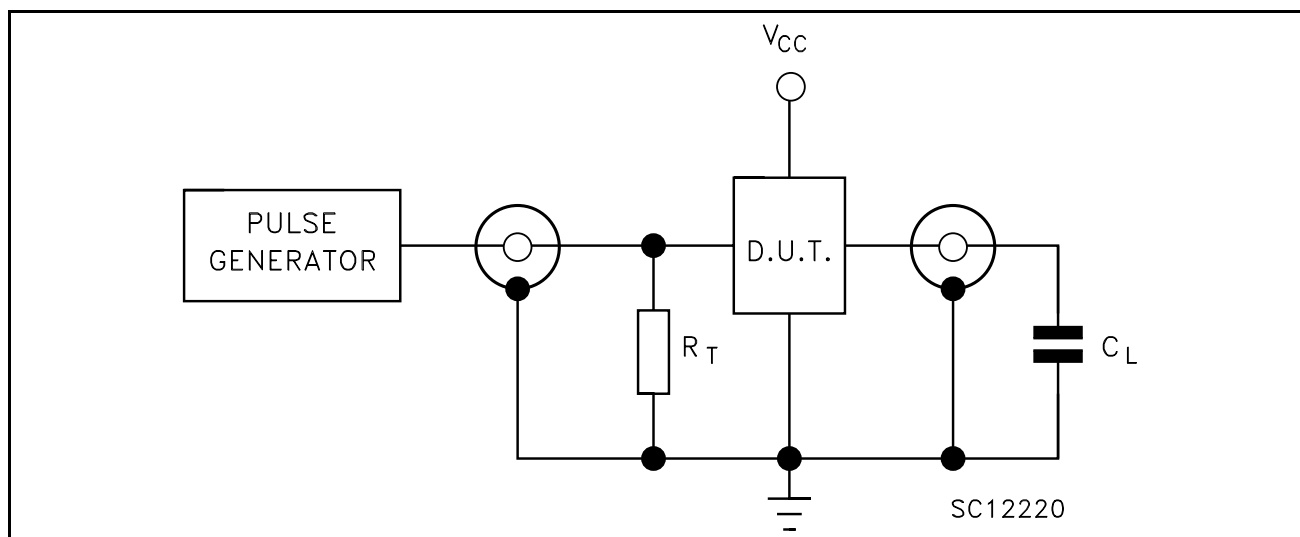
Figure 4: Test Circuit

$C_L = 50 \text{ pF}/150 \text{ pF}$ or equivalent (includes jig and probe capacitance)
 $R_T = Z_{OUT}$ of pulse generator (typically 50Ω)

Figure 5: Waveform - Propagation Delay Time (f=1MHz; 50% duty cycle)

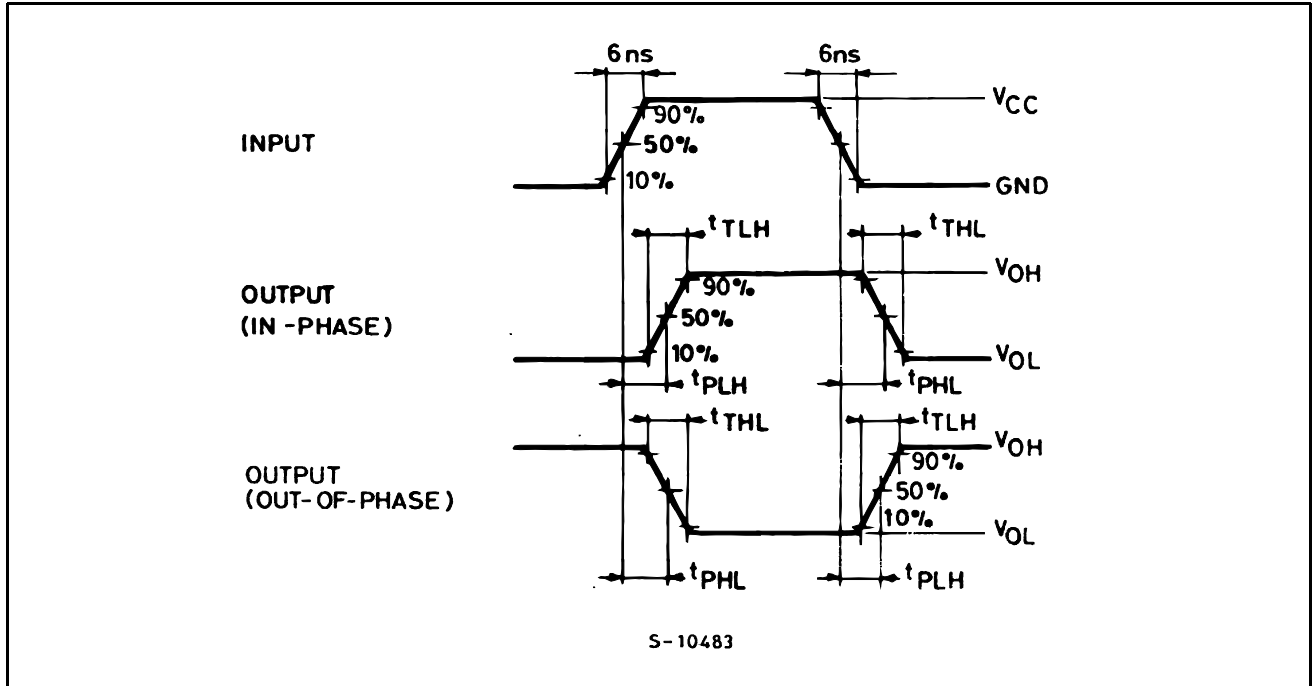

DILC-20 MECHANICAL DATA

DIM.	mm.			inch		
	MIN.	TYP	MAX.	MIN.	TYP.	MAX.
A	2.1		2.71	0.083		0.107
a1	3.00		3.70	0.118		0.146
a2	0.63	0.88	1.14	0.025	0.035	0.045
B	1.93	2.03	2.23	0.076	0.080	0.088
b	0.40	0.45	0.50	0.016	0.018	0.020
b1	0.20	0.254	0.30	0.008	0.010	0.012
D	25.14	25.40	25.65	0.990	1.000	1.010
E	7.36	7.62	7.87	0.290	0.300	0.310
e		2.54			0.100	
e1	22.73	22.86	22.99	0.895	0.900	0.905
e2	7.62	7.87	8.12	0.300	0.310	0.320
F	7.29	7.49	7.70	0.287	0.295	0.303
l			3.86			0.152
K	11.30		11.56	0.445		0.455
L	1.14	1.27	1.40	0.045	0.050	0.055

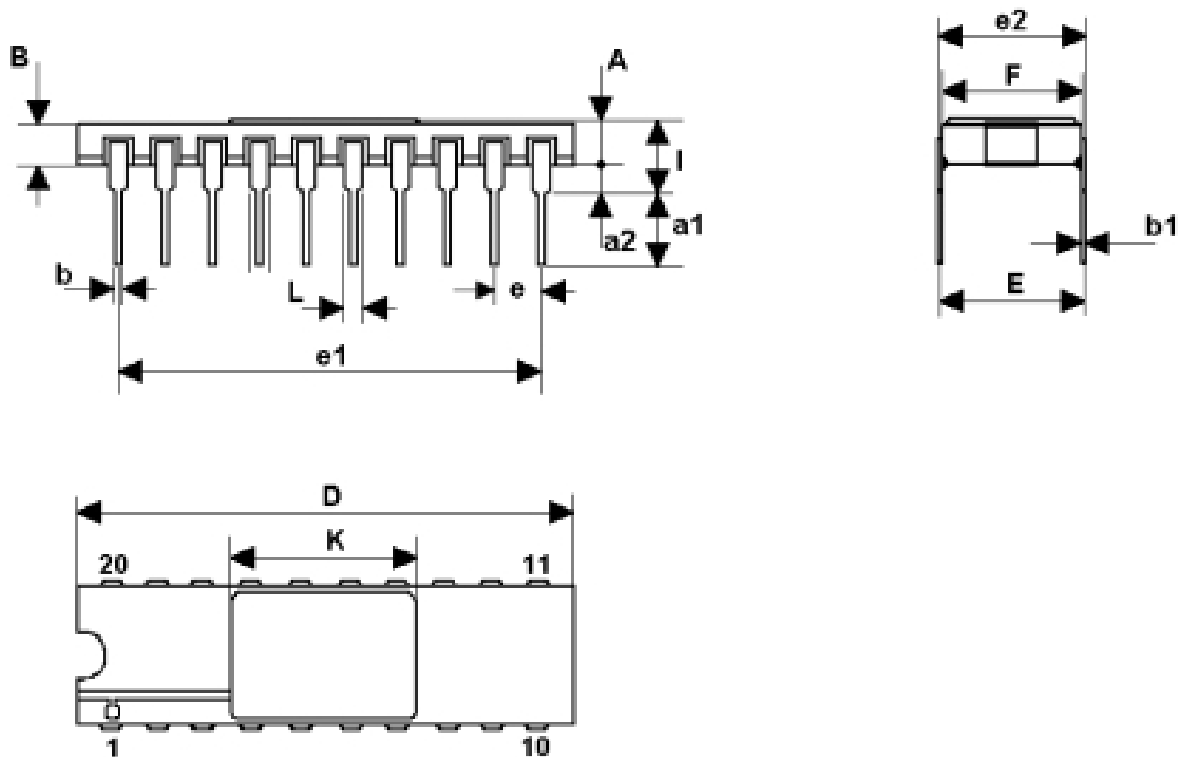

0016178J

FPC-20 MECHANICAL DATA

DIM.	mm.			inch		
	MIN.	TYP	MAX.	MIN.	TYP.	MAX.
A	9.98	10.16	10.34	0.393	0.400	0.407
B	9.98	10.16	10.34	0.393	0.400	0.407
C	1.45	1.61	1.78	0.57	0.63	0.070
D	0.10	0.127	0.18	0.004	0.005	0.007
E	11.30	11.43	11.56	0.445	0.450	0.455
F		1.27			0.050	
G	0.38	0.43	0.48	0.015	0.017	0.019
H	7.24		8.16	0.285		0.320
L	24.46		26.67	0.960		1.050
M	0.45	0.50	0.55	0.018	0.020	0.022
N		7.87			0.310	
O	1.14	1.27	1.40	0.045	0.050	0.055
P	0.10	0.18	0.25	0.004	0.007	0.010

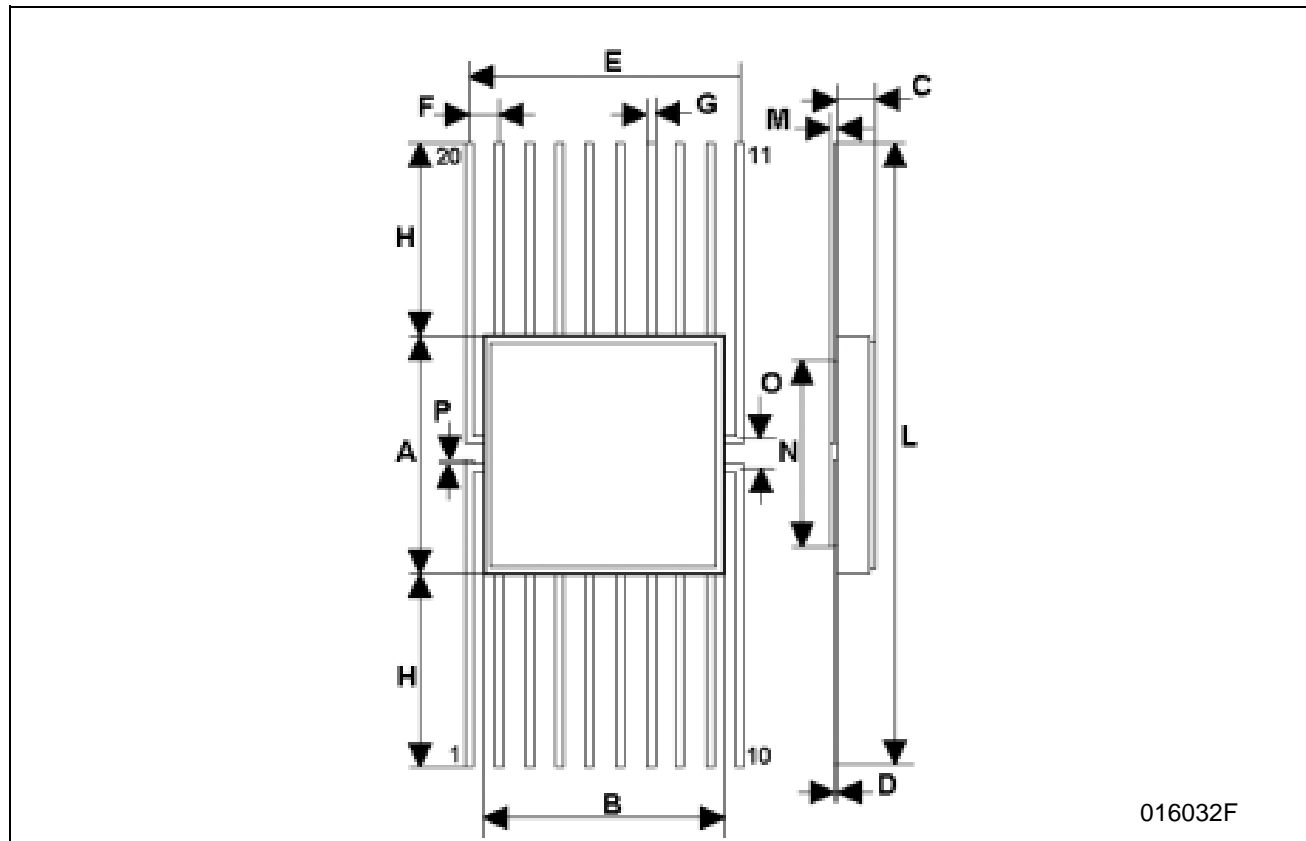

Table 8: Revision History

Date	Revision	Description of Changes
01-Jun-2004	1	First Release

Information furnished is believed to be accurate and reliable. However, STMicroelectronics assumes no responsibility for the consequences of use of such information nor for any infringement of patents or other rights of third parties which may result from its use. No license is granted by implication or otherwise under any patent or patent rights of STMicroelectronics. Specifications mentioned in this publication are subject to change without notice. This publication supersedes and replaces all information previously supplied. STMicroelectronics products are not authorized for use as critical components in life support devices or systems without express written approval of STMicroelectronics.

**The ST logo is a registered trademark of STMicroelectronics
All other names are the property of their respective owners**

**© 2004 STMicroelectronics - All Rights Reserved
STMicroelectronics GROUP OF COMPANIES**

**Australia - Belgium - Brazil - Canada - China - Czech Republic - Finland - France - Germany - Hong Kong - India - Israel - Italy - Japan -
Malaysia - Malta - Morocco - Singapore - Spain - Sweden - Switzerland - United Kingdom - United States.
<http://www.st.com>**