

commercial Switches and Sensors



Pressure

Mass airflow

Force

Humidity

Temperature

Position

Infrared

Current

Liquid level

Basic switches

Product solutions on the Interactive Catalogue



COMMERCIAL SWITCHES AND SENSORS

Honeywell's Commercial Switches and Sensors offer a wide selection of products and technology capability for applications in medical devices and equipment; heating, ventilation, air-conditioning and refrigeration; information technology; home appliances; motor control and automotive passenger cars. This catalogue contains a selection of our most popular, established product listings – all tried and tested in field applications. To view our complete range of products, visit our website at www.honeywell.com/sensing.

How to use this catalogue

For each referenced listing, key specification parameters, descriptions and mounting drawing information are presented. These listings illustrate our capabilities while the specifications included allow easy differentiation between similar products.

There are, of course, many more product options available. Full product specification information may be accessed on our website (www.honeywell.com/sensing). At the Home page enter the catalogue listing reference in the SEARCH box and click GO! This will take you directly to the interactive catalogue/specification search tables for this listing. Alternatively, select and click the interactive catalogue icon on the Home page and then choose a product category against which to do a specification search.

Also on the website you can access installation instructions, application notes, Frequently Asked Questions (FAQs), selection guides and additional technical information.

Mounting dimensions

Mounting dimensions shown in each product section are for reference only. For exacting layout work, request an engineering drawing from your nearest Honeywell sales office. Where dual dimensions are shown on mounting drawings, the first or upper one is millimetres (mm) and the second or lower is inches (in). Where single dimensions are shown, they are millimetres (mm), unless otherwise stated.

To order these products

Simply contact your local Honeywell Distributor or your local Honeywell office. More information on Honeywell products and how to contact us can be found at <http://locator.micro.honeywell.com/>



Interactive Catalog

www.honeywell.com/sensing

System critical sensing solutions

A system is critical if the quality, reliability, delivery and customer service associated with a component part is essential to the performance of the operation or end product. If a sensor or switch is critical to the performance, cost effectiveness, delivery or safety of a product or operation, then it is system critical. It is therefore a defining element in the performance of the system under whatever conditions apply. Failure of the component – or failure of delivery of the component – results in lost productivity, increased costs or a catastrophic event such as a shutdown. Therefore selecting the right product is essential. It can make the difference between success and failure.

Honeywell – delivering excellence

To deliver the right products for our customers' applications we listen to them to understand their needs. Using techniques such as "Voice of the Customer" and "Concept Engineering" we make sure that the products and solutions we deliver are the right ones. As part of Honeywell we can use local knowledge and understanding combined with global expertise and resources to achieve this. We can deploy many key technologies to bring innovative solutions to customers' problems.

Our products are manufactured to work well and to last. We use Six Sigma Plus productivity to ensure this is the case. We have award winning manufacturing facilities around the world and recognised world class business excellence in manufacturing and supply chain management to deliver on time, anywhere in the world.

Our e-business approach offers instant access to product information, technical support and application knowledge through our Internet site. Check out our powerful new interactive catalogue that can search and find the right products for customers' needs and deliver a drawing ready for incorporation in a CAD system direct to your desk.

And of course, we manage our whole business for the benefit of our customers, using an acknowledged world-class business excellence approach that incorporates Six Sigma principles.

CONTENTS***Pressure Sensors*** Page 4

Absolute, differential, gauge, and vacuum gauge pressure sensors for media that are compatible with a silicon diaphragm. These sensors are ideal for low-cost commercial grade applications, such as printed circuit boards. Small and reliable, they offer excellent repeatability and high accuracy under varying environmental conditions.

Mass Airflow Sensors Page 10

Amplified and unamplified microbridge mass airflow sensors provide a sensitive and fast response and high accuracy over a broad range of gas and air flows.

Force Sensors Page 12

Compact, extremely sensitive devices for precise, reliable performance in any application that requires precision force measurement.

Humidity Sensors Page 13

Relative humidity sensors with on-chip signal conditioning. Chemically resistant packaging to accommodate harsh environments. Sensor construction consists of a planar capacitor with a second polymer layer to protect against dirt, dust, oils and other hazards.

Temperature Sensors Page 14

Platinum and silicon-based thin film resistance temperature devices (RTDs) for applications that require small package size, accuracy and linear outputs.

Position Sensors Page 16

Hall effect and magnetoresistive sensors for all applications that require accurate, reliable outputs.

Infrared Products Page 20

Optoelectronic standard infrared emitting diodes (IREDs), sensors and assemblies for object presence, limit and motion sensing, position encoding and movement encoding.

Current Sensors Page 26

Adjustable linear null balance, digital and linear output current sensors for monitoring ac or dc current.

Liquid Level Sensors Page 30

Sensitive sensors in a variety of housing types for detecting the presence or absence of a wide range of liquids.

Basic Switches Page 31

Standard, miniature and subminiature switches, available in a range of enclosures and with a variety of actuators. They are ideal for use alone or built into assemblies.

⚠ WARNING**PERSONAL INJURY**

DO NOT USE these products as safety or emergency stop devices, or in any other application where failure of the product could result in personal injury

Failure to comply with these instructions could result in death or serious injury.

⚠ WARNING**MISUSE OF DOCUMENTATION**

- The information presented in this product sheet (or catalogue) is for reference only. DO NOT USE this document as product installation information.
- Complete installation, operation and maintenance information is provided in the instructions supplied with each product.

Failure to comply with these instructions could result in death or serious injury.

Pressure Sensors



24PC/26PC Series

Signal conditioning: Unamplified noncompensated- (24PC Series) compensated - (26PC Series)

Supply voltage: 10 Vdc typ. 12 Vdc max. (24PC Series) 16 Vdc max. (26PC Series)

Operating temperature: -40 °C to 85 °C -40 °F to 185 °F

Port style: Straight or Flow Through

Termination: PCB; 1 x 4; 0.600 in (Type 6) PCB; 2 x 2; (Type 2) 1 x 4 with connector (Type 5)

OPTIONS

Differential

MOUNTING DIMENSIONS (for reference only) mm/in
DIFFERENTIAL SENSOR
1 X 4 Termination (Style 6) Port Style A, Straight (Only)

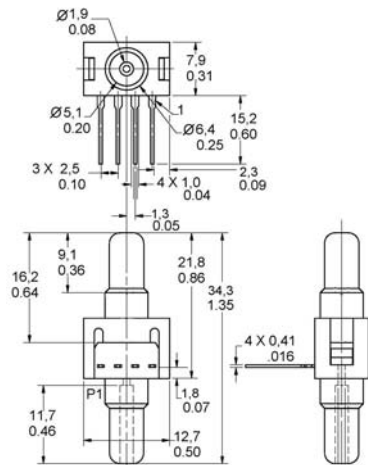

Gauge

MOUNTING DIMENSIONS (for reference only) mm/in
GAUGE SENSOR
1 x 4 Termination (Style 6) Port Style A, Straight
Pin 1 is notched, Pin 2 is next to Pin 1, etc.

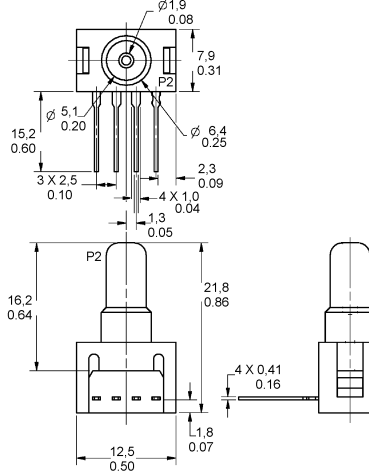

24PC Series

MEASUREMENT TYPE	PRESSURE RANGE	REFERENCE
Gauge/Vacuum Gauge	1.0 psi	24PCFA6G
Differential/Vacuum Gauge	5.0 psi	24PCBFA6D
Gauge/Vacuum Gauge	5.0 psi	24PCBFA6G
Differential/Vacuum Gauge	15.0 psi	24PCCFA6D
Gauge/Vacuum Gauge	15.0 psi	24PCCFA6G
Differential/Vacuum Gauge	30.0 psi	24PCDFA6D
Gauge/Vacuum Gauge	30.0 psi	24PCDFA6G
Differential Gauge	0.5 psi	24PCEFA6D
Gauge	0.5 psi	24PCEFA6G
Differential Gauge	100 psi	24PCFFA6D
Gauge	100 psi	24PCFFA6G

26PC Series

MEASUREMENT TYPE	PRESSURE RANGE	REFERENCE
Differential/Vacuum Gauge	1.0 psi	26PCFA6D
Gauge/Vacuum Gauge	1.0 psi	26PCFA6G
Differential Gauge	5.0 psi	26PCBFA6D
Gauge	5.0 psi	26PCBFA6G
Differential/Vacuum Gauge	15.0 psi	26PCCFA6D
Gauge/Vacuum Gauge	15.0 psi	26PCCFA6G
Differential Gauge	30.0 psi	26PCDFA6D
Gauge	30.0 psi	26PCDFA6G
Gauge	100 psi	26PCFFA6G
Differential	250 psi	26PCGFA6D

Flow Through Type 6

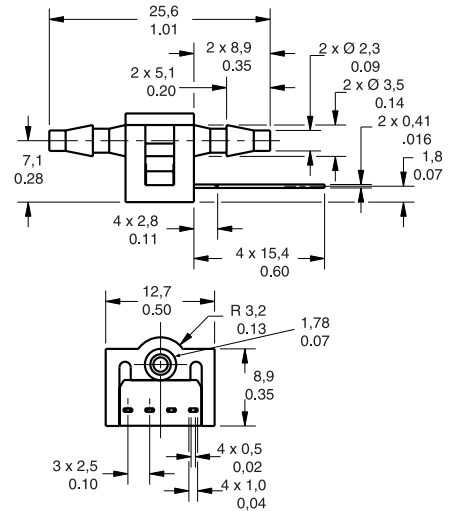

24PC Series

MEASUREMENT TYPE	PRESSURE RANGE	REFERENCE
Flow Through/Vacuum Gauge	15.0 psi	24PCCFG6G
Flow Through/Vacuum Gauge	30.0 psi	24PCDFG6G

26PC Series

MEASUREMENT TYPE	PRESSURE RANGE	REFERENCE
Flow Through/Vacuum Gauge	1.0 psi	26PCAFG6G
Flow Through	15.0 psi	26PCCFG6G
Gauge/Vacuum Gauge	100 psi	26PCFFG6G

24PC/26PC Series (Continued)

Type 2

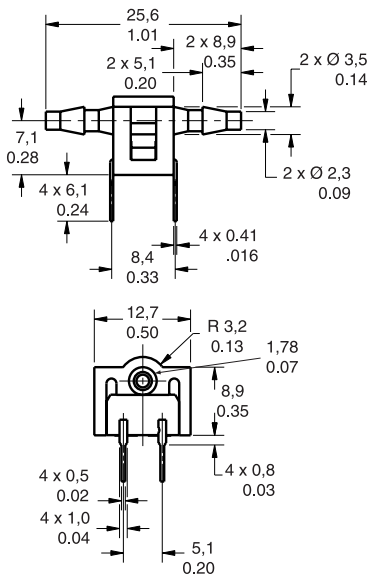

26PC Series

MEASUREMENT TYPE	PRESSURE RANGE	REFERENCE
Flow Through	30.0 psi	26PCDFG2G

Type 5

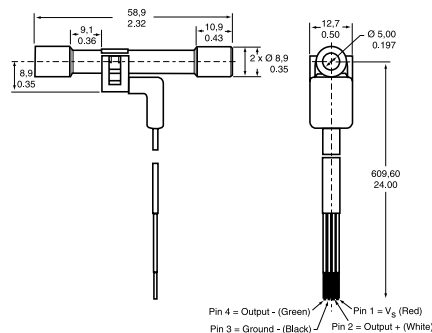

26PC Series

MEASUREMENT TYPE	PRESSURE RANGE	REFERENCE
Flow Through/Vacuum Gauge	100 psi	26PCFU5G

24PC/26PC SMT (Surface Mount Technology)

Signal conditioning: Unamplified noncompensated - (24PC SMT Series) compensated - (26PC SMT Series)

Supply voltage: 10 Vdc typ. 12 Vdc max. (24PC SMT Series) 16 Vdc max. (26PC SMT Series)

Operating temperature: -40 °C to 85 °C -40 °F to 185 °F

Port style: Straight, 1.88 mm Ø (0.74 in)

Termination: SMT solder

Measurement type: Gauge, Vacuum Gauge, Differential, Wet/Wet Differential

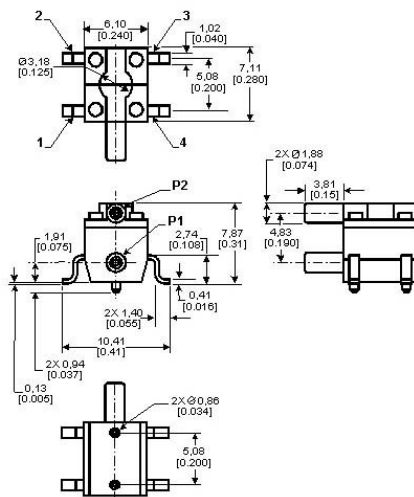

OPTIONS

24PC SMT Series

PRESSURE RANGE	REFERENCE
0 psi to 1.0 psi	24PC01SMT
0 psi to 5.0 psi	24PC05SMT
0 psi to 15.0 psi	24PC15SMT

26PC SMT Series

PRESSURE RANGE	REFERENCE
0 psi to 1.0 psi	26PC01SMT
0 psi to 5.0 psi	26PC05SMT
0 psi to 15.0 psi	26PC15SMT

CPC/CPX Series Low Pressure

Signal conditioning: Unamplified compensated - (CPC Series) noncompensated - (CPX Series)

Supply voltage: 12 Vdc typ. 16 Vdc max.

Operating temperature: -25 °C to 85 °C -13 °F to 185 °F

Port style: Barbed

Termination: PCB

Accuracy grade: Commercial (1.0 %)

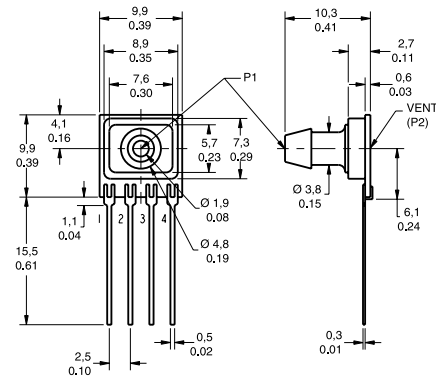

OPTIONS

CPC Series

MEASUREMENT TYPE	PRESSURE RANGE	REFERENCE
Differential	(1.0 psi) 4.0 in H ₂ O	CPCL04DFC
Gauge	(1.0 psi) 4.0 in H ₂ O	CPCL04GFC
Differential	(1.0 psi) 10.0 in H ₂ O	CPCL10DFC

CPX Series

MEASUREMENT TYPE	PRESSURE RANGE	REFERENCE
Differential	4.0 in H ₂ O	CPXL04DF
Differential	10.0 in H ₂ O	CPXL10DF

DC Series, Low Pressure

Signal conditioning: Amplified compensated unregulated (DC001NDC4) regulated (DC005NDR4)

Supply voltage: 5 Vdc typ., 5.1 Vdc max. (DC001NDC4)
7 Vdc to 35 Vdc (DC005NDR4)

Operating temperature: -25 °C to 85 °C
-13 °F to 185 °F

Port style: Barbed

Termination: PCB

OPTIONS

DC001NDC4

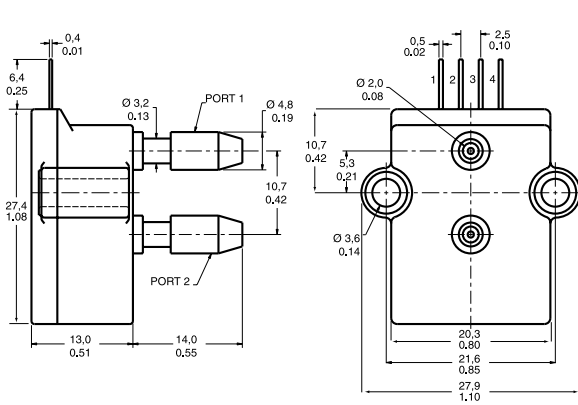

MEASUREMENT TYPE	PRESSURE RANGE	REFERENCE
Differential	1.0 in H ₂ O	DC001NDC4

DC005NDR4

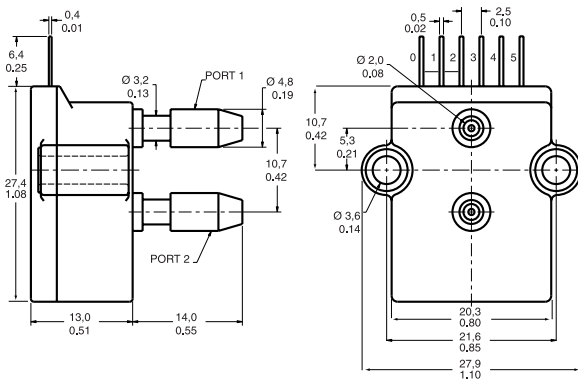

MEASUREMENT TYPE	PRESSURE RANGE	REFERENCE
Differential	5.0 in H ₂ O	DC005NDR4

DCXL/DUXL Series, Low Pressure

Signal conditioning: Unamplified compensated (DCXL) noncompensated (DUXL)

Supply voltage: 12 Vdc typ., 16 Vdc max. (DCXL)
4.5 Vdc min., 8 Vdc max. (DUXL)

Operating temperature: -25 °C to 85 °C
-13 °F to 185 °F

Port style: Barbed

Termination: PCB

OPTIONS

DCXL Series

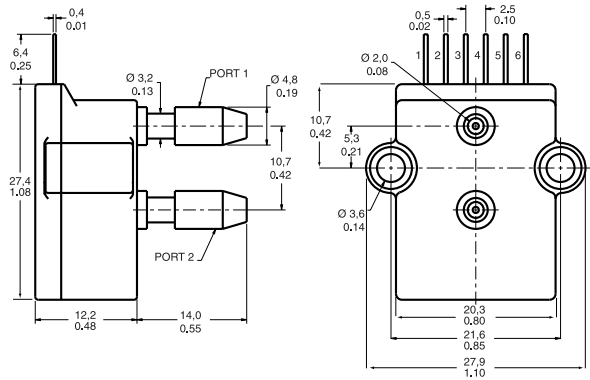

MEASUREMENT TYPE	PRESSURE RANGE	REFERENCE
Differential	1.0 in H ₂ O	DCXL01DN
Differential	10.0 in H ₂ O	DCXL10DN

DUXL Series

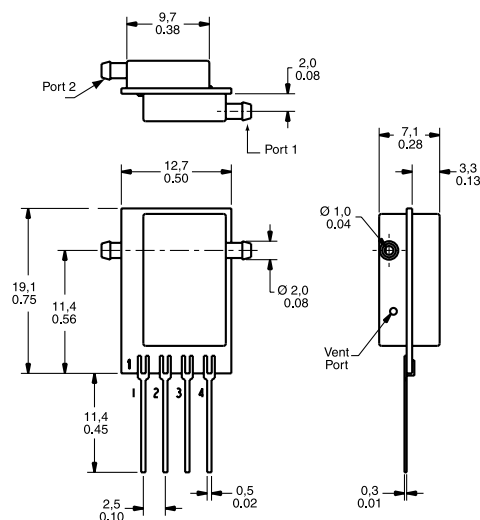

MEASUREMENT TYPE	PRESSURE RANGE	REFERENCE
Differential	1.0 in H ₂ O	DUXL01D
Differential	10.0 in H ₂ O	DUXL10D

XCA Series

Signal conditioning: Unamplified compensated
Supply voltage: 5 Vdc typ., 16 Vdc max.
Operating temperature: -25 °C to 85 °C
 -13 °F to 185 °F
Port style: Barbed
Termination: PCB

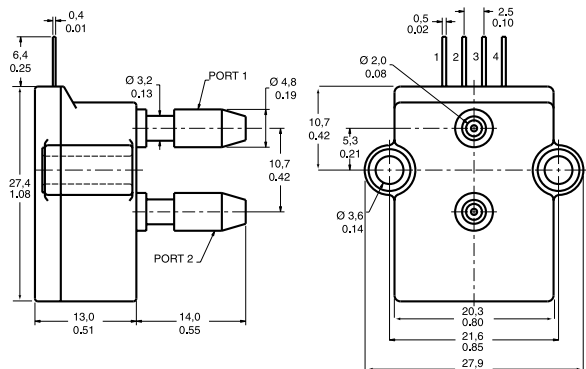

MEASUREMENT TYPE	PRESSURE RANGE	REFERENCE
Absolute	15.0 psia	XCA415AN

XCX Series

Signal conditioning: Unamplified compensated
Supply voltage: 12 Vdc typ., 16 Vdc max.
Operating temperature: -25 °C to 85 °C
 -13 °F to 185 °F
Port style: Barbed
Termination: PCB
Accuracy grade: Commercial (1.0 %)

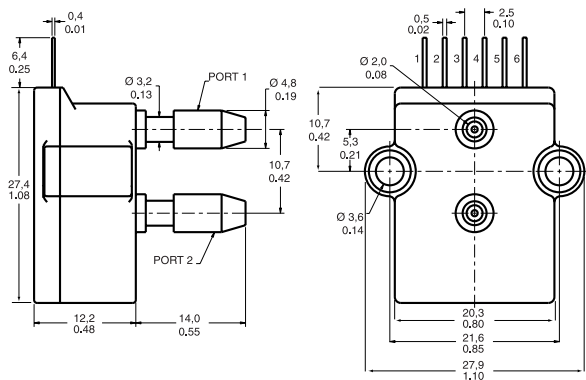

MEASUREMENT TYPE	PRESSURE RANGE	ACCURACY GRADE	REFERENCE
Differential	1.0 psi		XCX01DNC
Differential	1.0 psi	High (0.50 %)	XCX01DNH
Differential	15.0 psi		XCX15DNC

XPC Series

Signal conditioning: Unamplified compensated
Supply voltage: 12 Vdc typ., 16 Vdc max.
Operating temperature: -25 °C to 85 °C
 -13 °F to 185 °F
Port style: Barbed
Termination: PCB
Accuracy grade: Commercial (1.0 %)

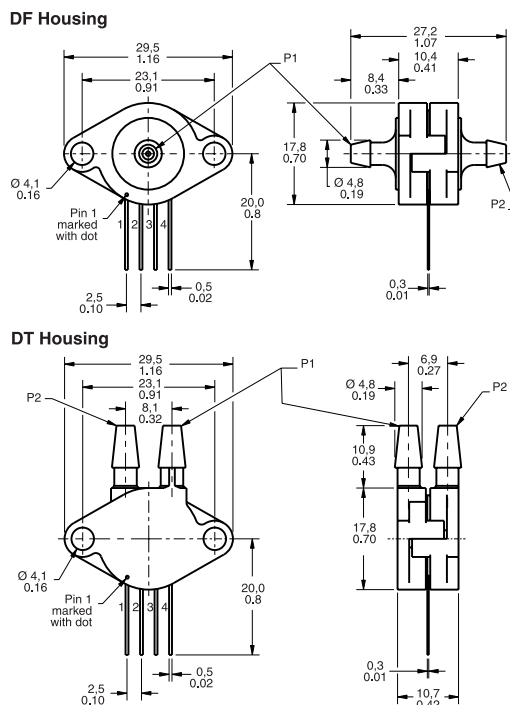

MEASUREMENT TYPE	PRESSURE RANGE	PORT STYLE	REFERENCE
Differential	1.0 psi	Axial	XPC01DFC
Differential	15.0 psi	Radial	XPC15DTC

XSX Series, Low pressure

Signal conditioning:

Unamplified
uncompensated
12 Vdc typ., 16 Vdc max.
-25 °C to 85 °C
-13 °F to 185 °F
Button
PCB
Commercial (1.0 %)

Supply voltage:

Operating temperature:

Port style:

Termination:

Accuracy grade:

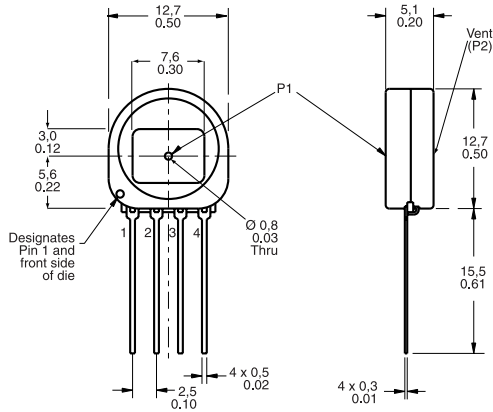

MEASUREMENT TYPE	PRESSURE RANGE	REFERENCE
Gauge	4.0 in H ₂ O	XSXL04GF

40PC Series, Miniature Signal Conditioned

Signal conditioning:

Supply voltage:

Operating temperature:

Port style:

Termination:

Amplified
5 Vdc ± 0.25 Vdc
-45 °C to 125 °C
-49 °F to 257 °F
Straight for O-ring interface
PCB, unformed

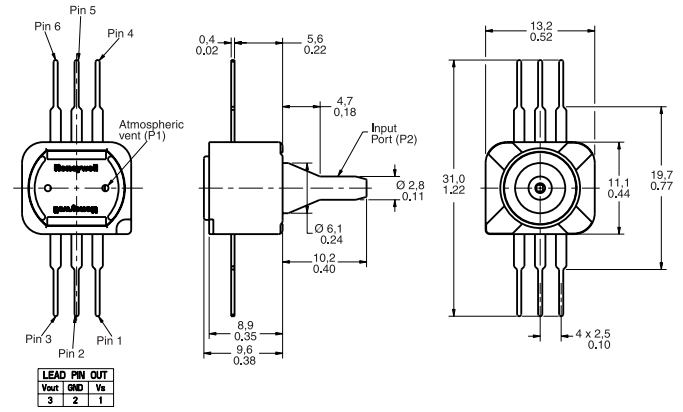

MEASUREMENT TYPE	PRESSURE RANGE	REFERENCE
Bi-Directional Gauge/Vacuum Gauge	± 50 mm Hg	40PC001B1A
Gauge	0 to 300 mm HG	40PC006G1A
Vacuum	0 to -15.0 psi	40PC015V1A
Gauge	15.0 psi	40PC015G1A
Gauge	30.0 psi	40PC030G1A
Gauge	100 psi	40PC100G1A
Gauge	150 psi	40PC150G1A
Gauge	250 psi	40PC250G1A
Gauge	500 psi	40PC500G1A

140PC Series

Signal conditioning:
Supply voltage:
Operating temperature:

Amplified
 8 Vdc typ., 16 Vdc max.
 -40 °C to 85 °C
 -40 °F to 185 °F
 Straight
 PCB

Port style:
Termination:

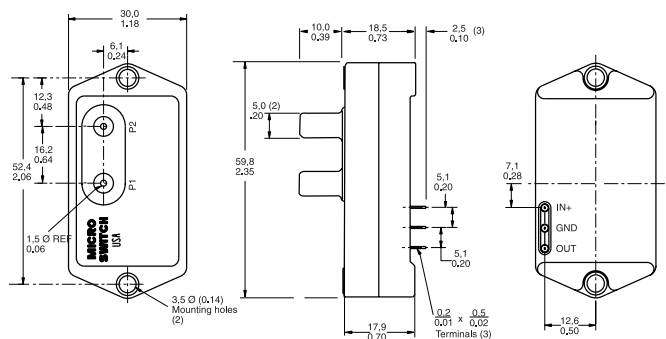

Note: Dimensions shown apply to Differential and Absolute versions. Gauge units are identical, except the P1 port is absent.

MEASUREMENT TYPE	PRESSURE RANGE	TERMINATION	REFERENCE
Gauge/Vacuum Gauge	-15 psi		141PC15G
Differential/Vacuum Gauge	1.0 psi		142PC01D
Gauge	1.0 psi		142PC01G
Gauge	2.0 psi		142PC02G
Differential/Vacuum Gauge	5.0 psi		142PC05D
Differential/Vacuum Gauge	-39 in H ₂ O to 55 in H ₂ O		142PC05D97
Gauge	5.0 psi		142PC05G
Absolute	15 psia		142PC15A
Absolute	15 psia	Leadwire	142PC15AW95
Gauge	15 psi		142PC15G
Differential/Vacuum Gauge	± 2.5 psi		143PC03D
Differential/Vacuum Gauge	± 5.0 psi	Leadwire	143PC05DW

160PC Series, Low Pressure

Signal conditioning:
Supply voltage:
Operating temperature:

Amplified
 8 Vdc typ., 16 Vdc max.
 -40 °C to 85 °C
 -40 °F to 185 °F
 Straight
 PCB

Port style:
Termination:

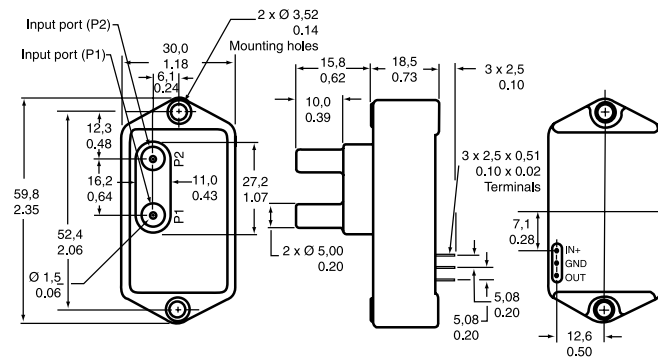

Note: Dimensions shown apply to Differential and Absolute versions. Gauge units are identical, except the P1 port is absent.

MEASUREMENT TYPE	PRESSURE RANGE	SUPPLY VOLTAGE	REFERENCE
Differential/Vacuum Gauge	0 to 27.68 in H ₂ O		162PC01D
Differential/Vacuum Gauge	± 5.0 in H ₂ O		163PC01D36
Differential/Vacuum Gauge	-20 cm to 120 cm H ₂ O	5 Vdc	163PC01D48
Differential/Vacuum Gauge	-20 cm to 120 cm H ₂ O		163PC01D61
Differential/Vacuum Gauge	± 2.5 in H ₂ O		163PC01D75
Differential/Vacuum Gauge	10.0 in H ₂ O		164PC01D37
Differential/Vacuum Gauge	5,0 in H ₂ O		164PC01D76

Mass Airflow Sensors



AWM2000 Series

The AWM2000 Series microbridge mass airflow sensor is a passive device comprised of two Wheatstone bridges and has bidirectional sensing capability. The heater control circuit is required for operation per specifications. The sensing bridge supply circuit is also required for operation per specifications. These two circuits are not on board the package and must be supplied in the application. The differential amplifier is a useful interface for the sensing bridge. It can be used to introduce gain and to voltage offsets to the sensor output.

Signal conditioning: Unamplified (-44,5 mVdc to 44,5 mVdc)

Port style: Straight

Sensor resistance: 5 kOhm

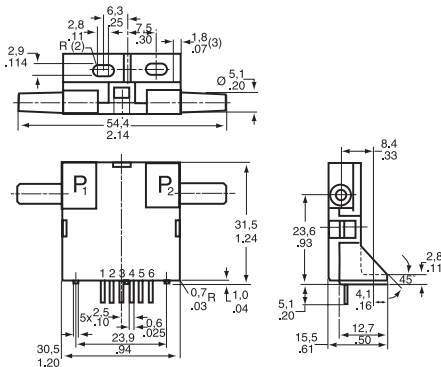

FLOW/PRESSURE RANGE	REFERENCE
± 200 sccm	AWM2100V
± 4.0 in H ₂ O (10 mBar)	AWM2200V
± 1000 sccm (1 SLPM)	AWM2300V

Mass Airflow sensors contain a thin-film, thermally isolated bridge structure containing heater and temperature sensing elements. The bridge structure provides a sensitive and fast response to the flow of air or other gas over the chip.

State-of-the-art chip design and manufacturing techniques allow the microbridge to be remarkably sensitive, fast, small. Used wherever airflow needs to be measured.

Supply voltage:

Operating temperature:

Media compatibility:

8 Vdc to 15 Vdc

-25 °C to 85 °C (-13 °F to 185 °F)

Dry gas only

AWM3000 Series

Like the AWM2000 Series, the dual Wheatstone bridges control airflow measurement. The AWM3000 Series is amplified; therefore, it can be used to increase the gain and to introduce voltage offsets to the sensor output. The heater control circuit and the sensing bridge supply circuit are on board the package.

Signal conditioning:

Amplified (1 Vdc to 5 Vdc)

Port style:

Straight

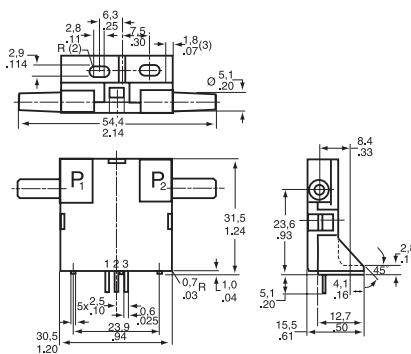

FLOW/PRESSURE RANGE	REFERENCE
± 200 sccm	AWM3100V
+ 2.0 in H ₂ O (5 mBar)	AWM3200V
± 1000 sccm (1 SLPM)	AWM3300V

AWM4000 Series

The microbridge mass airflow sensor operates on the theory of heat transfer. Mass airflow is directed across the surface of the sensing elements. Output voltage varies in proportion to the mass air or other gas flow through the inlet and outlet ports of the package. The specially designed housing precisely directs and controls the airflow across the microstructure sensing element. Mechanical design of the package allows it to be easily mounted to printed circuit boards.

The microbridge mass airflow sensor has a unique silicon chip based on advanced microstructure technology. It consists of a thin-film, thermally isolated bridge structure containing heater and temperature sensing elements. The bridge structure provides a sensitive and fast response to the flow of air or other gas over the chip. Dual sensing elements positioned on both sides of a central heating element indicate flow direction as well as flow rate. Laser trimmed thick film and thin film resistors provide consistent interchangeability from one device to the next.

Port style:

Manifold

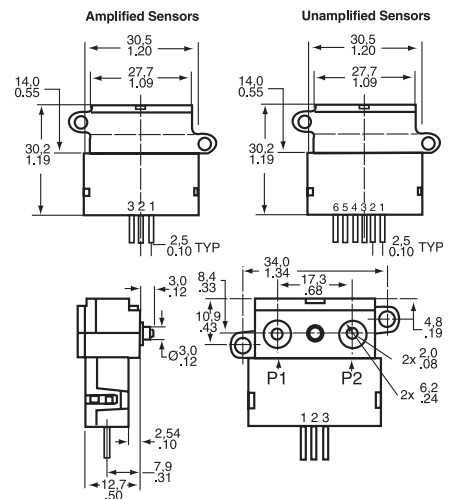

SIGNAL CONDITIONING	FLOW/PRESSURE RANGE	REFERENCE
Unamplified (8.5 mV)	± 25 sccm	AWM42150VH
Unamplified (54.7 mV)	± 1000 sccm (1 SLPM)	AWM42300V
Amplified (1 Vdc to 5 Vdc)	± 1000 sccm (1 SLPM)	AWM43300V
Amplified (1 Vdc to 5 Vdc)	+ 6 SLPM	AWM43600V

AWM5000 Series - High flow

AWM5000 Series Microbridge Mass Airflow Sensors feature a Venturi type flow housing. They measure flow as high as 20 standard liters per minute (SLPM) while inducing a maximum pressure drop of 2.25 inches H₂O. The microbridge chip is in direct contact with the flow stream, greatly reducing error possibilities due to orifice or bypass channel clogging.

The rugged plastic package has been designed to withstand common mode pressures up to 50 psi, and the small sensing element allows 100 g of shock without compromising performance. The included "AMP" compatible connector provides reliable connection in demanding applications.

Each AWM5000 sensor contains circuitry which performs amplification, linearization, temperature compensation, and gas calibration. A 1 to 5 Vdc linear output is possible for all listings regardless of flow range (5, 10, 15, or 20 SLPM) or calibration gas (nitrogen, carbon dioxide, nitrous oxide, or argon). All calibration is performed by active laser.

Signal conditioning:

Amplified (1 Vdc to 5 Vdc)

Port style:

Threaded, 1/4" NPT

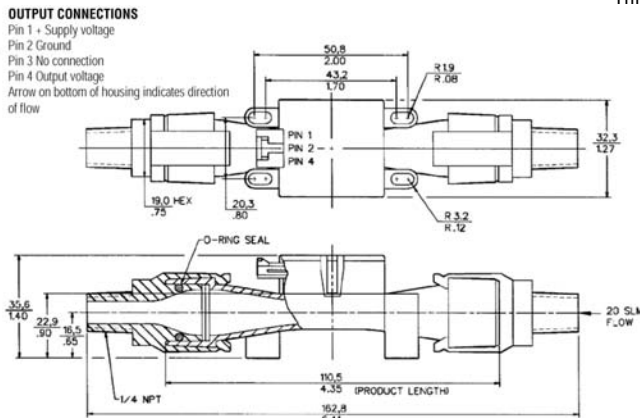

FLOW/PRESSURE RANGE

- 0 SLPM to 5 SLPM (N₂ calibration)
- 0 SLPM TO 10 SLPM (N₂ calibration)
- 0 SLPM to 20 SLPM (CO₂ calibration)
- 0 SLPM to 20 SLPM (N₂ calibration)

REFERENCE

- AWM5101VN
- AWM5102VN
- AWM5104VC
- AWM5104VN

AWM700 Series

AWM700 Series microbridge mass airflow sensors provide in-line flow measurement with a specially designed bypass flow housing. The sensors measure flow as high as 200 standard liters per minute (SLPM) while inducing a pressure drop of 1 inch H₂O, typically. The AWM700 has a high flow range capability in a small package.

Signal conditioning:

Amplified (1 Vdc to 5 Vdc)

Port style:

Tapered, 22 mm

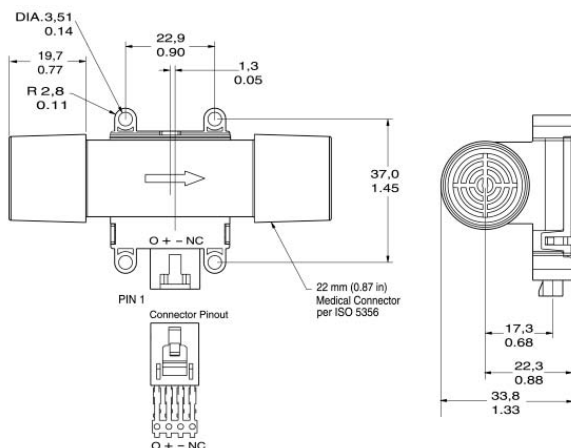

FLOW/PRESSURE RANGE

+ 200 SLPM

REFERENCE

AWM720P1

CAUTION
PRODUCT DAMAGE

AWM Series Microbridge Mass Airflow Sensors are not designed to sense liquid flow and will be damaged by liquid flow through the sensor.

Failure to comply with these instructions could result in product damage.

Force Sensors

Force sensors operate on the principle that the resistance of silicon implanted piezoresistors will increase when the resistors flex under any applied force. The sensor concentrates force from the application, through the stainless steel plunger, directly to the silicon sensing element. The amount of resistance changes in proportion to the amount of force being applied. This change in circuit resistance results in a corresponding mV output level.

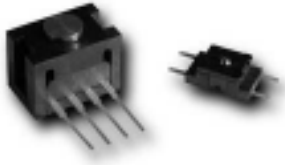

FSG Series

Plunger actuator - Force range 1500 g

Supply voltage: 360 mV span @ 10 Vdc
Operating temperature: -40 °C to 85 °C
 -40 °F to 185 °F
Sensitivity: 0.20 mV/g min., 0.24 mV/g typ., 0.28 mV/g max.
Overforce: 5500 g

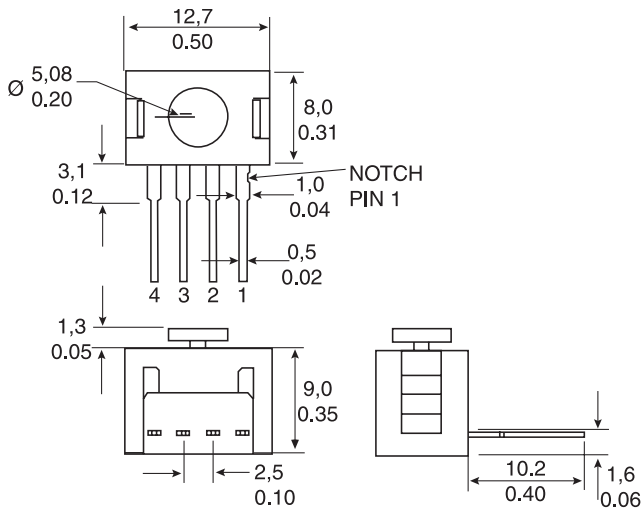

Non-compensated **REFERENCE** FSG15N1A

FSL Series

Ball bearing actuator - Force range 500 g

Supply voltage: 60 mV span @ 5 Vdc
Operating temperature: -40 °C to 85 °C
 -40 °F to 185 °F
Sensitivity: 0.10 mV/g min., 0.12 mV/g typ., 0.14 mV/g max.
Overforce: 4500 g

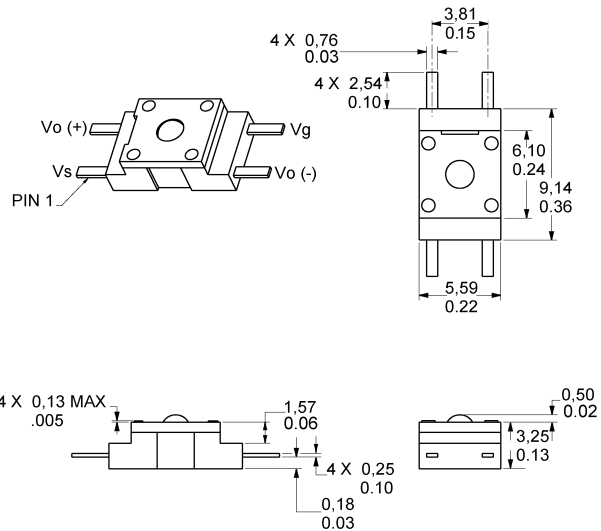

Non-compensated **REFERENCE** FSL05N2C

Humidity Sensors



Relative Humidity/Temperature and Relative Humidity sensors are configured with integrated circuitry to provide on-chip signal conditioning. These sensors contain a capacitive sensing die set in thermoset polymers that interacts with platinum electrodes. The laser trimmed sensors have an interchangeability of + 5%RH, with stable, low drift performance.

Absorption based humidity sensors provide both temperature and %RH (Relative Humidity) outputs. On-chip signal processing ensures linear voltage output versus %RH. Sensor laser trimming offers + 5%RH accuracy, and achieves 2%RH accuracy with calibration. Packages are chemically resistant and operate in ranges of -40 °C to 85 °C (-40 °F to 185 °F) to accommodate harsh environments.

Supply voltage: 4.0 Vdc to 5.8 Vdc
Operating humidity range: 0 to 100% RH, non-condensing
Operating temperature range: -40 °C to 85 °C (-40 °F to 185 °F)

HIH Series

OPTIONS

HIH-3610 Monolithic integrated circuit

The HIH-3610 humidity sensor is designed specifically for high volume OEM (Original Equipment Manufacturer) users. Direct input to a controller or other device is made possible by this sensor's linear voltage output. With a typical current draw of only 200 µA, the HIH-3610 is ideally suited for low drain, battery powered systems. Tight sensor interchangeability reduces or eliminates OEM production calibration costs. Individual sensor calibration data is available.

The HIH-3610 delivers instrumentation quality RH sensing performance in a low cost, solderable SIP (Single In-line Package). Available in two lead spacing configurations, the RH sensor is a laser trimmed thermoset polymer capacitive sensing element with on-chip integrated signal conditioning.

Package style:

Solderable SIP

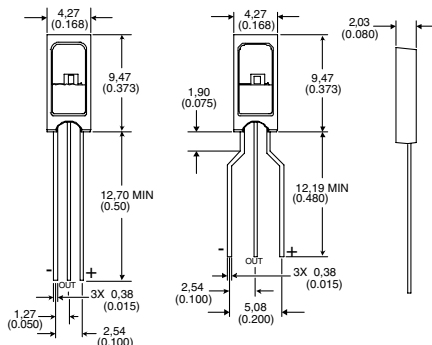

TERMINATION	NIST CERTIFICATION	REFERENCE
2.54 mm (0.100 in) Lead Pitch	None	HIH-3610-001
1.27 mm (0.050 in) Lead Pitch	None	HIH-3610-002
2.54 mm (0.100 in) Lead Pitch	NIST Calibration sensor-specific printout	HIH-3610-003
1.27 mm (0.050 in) Lead Pitch	NIST Calibration sensor-specific printout	HIH-3610-004

CAUTION PRODUCT DAMAGE

The inherent design of this component causes it to be sensitive to the electrostatic discharge (ESD). To prevent ESD-induced damage and/or degradation, take normal ESD precautions when handling this product.

Failure to comply with these instructions could result in product damage

HIH-3602 Monolithic integrated circuit

HIH-3602-A and HIH-3602-C Relative Humidity (RH) sensors combine both relative humidity and temperature sensing in a TO-5 housing with a hydrophobic sintered stainless steel filter.

The temperature sensor is thermally connected with the RH sensor making the HIH-3602-A/C ideal for measuring dew point and other absolute moisture terms.

Package style:

TO-5 can

Termination:

0.46 mm (0.18 in)

NIST Certification:

NIST Calibration sensor-specific printout

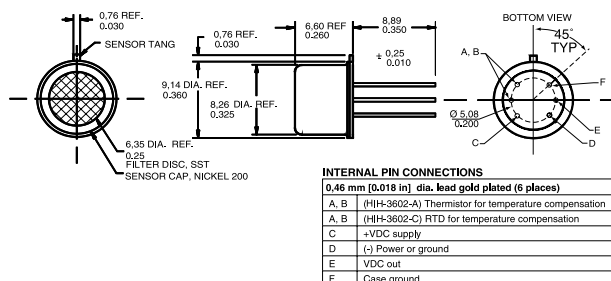

INTERNAL PIN CONNECTIONS
 0.46 mm [0.018 in] dia. lead gold plated (6 places)

A, B	(HIH-3602-A) Thermistor for temperature compensation
A, B	(HIH-3602-C) RTD for temperature compensation
C	+VDC supply
D	(-) Power or ground
E	VDC out
F	Case ground

TEMPERATURE SENSOR	REFERENCE
100 kOhm ± 5 % @ 25 °C, NTC 0-50 C	HIH-3602-A
1000 Ohm ± 0.2 % @ 0 °C, platinum RTD	HIH-3602-C

HIH-3602-L Integrated circuit

The HIH-3602-L Relative Humidity (RH) sensor delivers instrumentation quality RH sensing performance in a rugged, low cost, slotted TO-39 housing.

On-board signal conditioning reduces product development times while a typical current draw of only 200 mA makes the HIH-3602-L perfect for battery powered systems. This sensor should be shielded from bright light.

Package style:

TO-39 can

Termination:

0.46 mm (0.18 in)

NIST Certification:

None

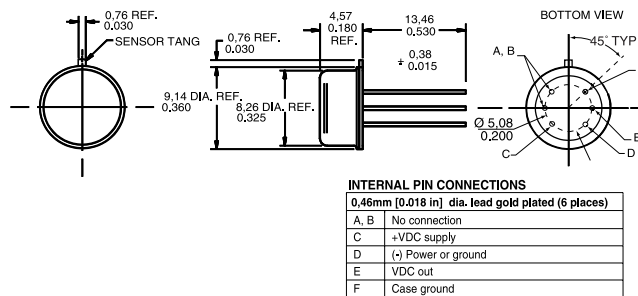

INTERNAL PIN CONNECTIONS
 0.46mm [0.018 in] dia. lead gold plated (6 places)

A, B	No connection
C	+VDC supply
D	(-) Power or ground
E	VDC out
F	Case ground

REFERENCE
HIH-3602-L

Temperature Sensors



Honeywell temperature sensors feature two distinct series. These sensors are thin film RTDs (Resistance Temperature Detectors) and are laser trimmed for accuracy and interchangeability. Linear outputs are stable and fast.

The TD Series Temperature Sensors are silicon-based RTDs. They offer 2000 Ohm nominal resistance at 20 °C. Temperature range of -40 °C to 150 °C.

The HEL Series Temperature Sensors are platinum RTDs, offering 100 Ohm or 1000 Ohm versions and temperature ranges of -200 °C to 540 °C.

HEL-700 Series 100/1000 Ohm platinum RTD

Supply voltage: 4 Vdc to 9 Vdc
 Base resistance and interchangeability: 1000 ± 2 Ohm (± 0.2 %) @ 0 °C (Standard)
 1000 ± 1 Ohm (± 0.1 %) @ 0 °C (Optional)

OPTIONS

HEL-700

Temperature range: -200 °C to 540 °C
 -300 °F to 1000 °F

Packaging style/Termination: Radial chip/ribbon leads (Type A)
 Radial chip/no leads (Type B)
 SMT (Axial) flip chip/no leads (Type C)

Type A

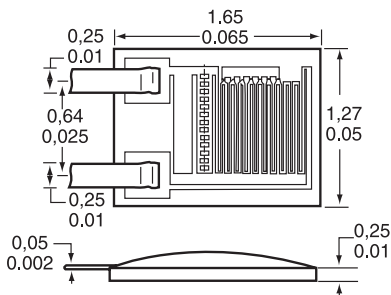

Type B

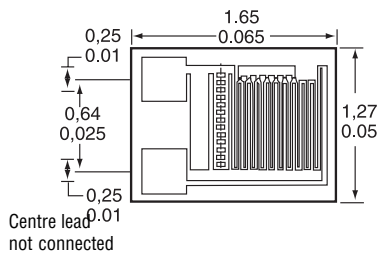

Type C

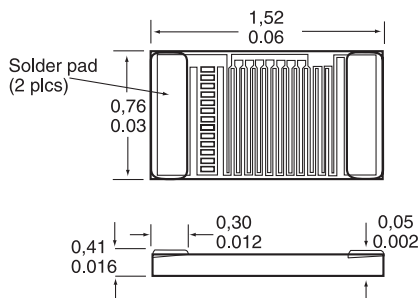

100 Ohm (0.00385 Ohm/Ohm/°C DIN standard)

PACKAGING STYLE	BASE RESISTANCE AND INTERCHANGEABILITY	REFERENCE
Type A	Standard	HEL-700-T-0-A
Type A	Optional	HEL-700-T-1-A
Type B	Standard	HEL-700-T-0-B
Type B	Optional	HEL-700-T-1-B

1000 Ohm (0.00375 Ohm/Ohm/°C)

PACKAGING STYLE	BASE RESISTANCE AND INTERCHANGEABILITY	REFERENCE
Type A	Standard	HEL-700-U-0-A
Type A	Optional	HEL-700-U-1-A
Type B	Standard	HEL-700-U-0-B
Type B	Optional	HEL-700-U-1-B
Type C	Standard	HEL-700-U-0-C
Type C	Optional	HEL-700-U-1-C

CAUTION

PRODUCT DAMAGE

The inherent design of this component causes it to be sensitive to the electrostatic discharge (ESD). To prevent ESD-induced damage and/or degradation, take normal ESD precautions when handling this product.

Failure to comply with these instructions could result in product damage

HEL-700 Series 100/1000 Ohm platinum RTD (Continued)

HEL-705/707/711/712/716/717

Temperature range:	HEL-705/711/716	-200 °C to 260 °C -320 °F to 500 °F
	HEL-707/712/717	-75 °C to 540 °C -100 °F to 1000 °F

Packaging style: Ceramic case
Termination: 12 in leadwires
NIST calibration: None

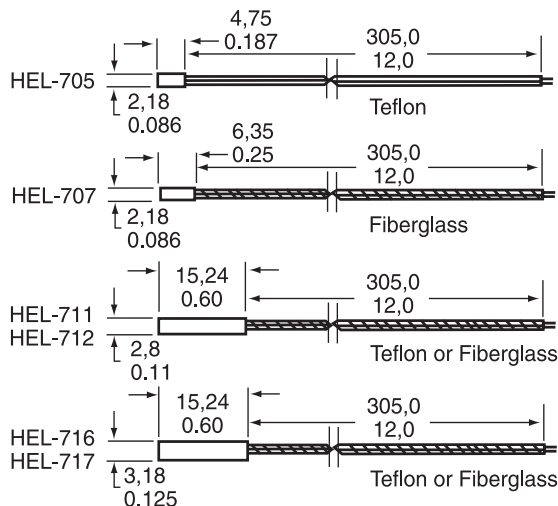

100 Ohm (0.00385 Ohm/Ohm/°C DIN standard)

BASE RESISTANCE AND INTERCHANGEABILITY	REFERENCE
Standard	HEL-705-T-0-12-00
Optional	HEL-705-T-1-12-00
Standard	HEL-707-T-0-12-00
Optional	HEL-707-T-1-12-00
Standard	HEL-711-T-0-12-00
Optional	HEL-711-T-1-12-00
Standard	HEL-712-T-0-12-00
Optional	HEL-712-T-1-12-00
Standard	HEL-716-T-0-12-00
Optional	HEL-716-T-1-12-00
Standard	HEL-717-T-0-12-00
Optional	HEL-717-T-1-12-00

1000 Ohm (0.00375 Ohm/Ohm/°C)

BASE RESISTANCE AND INTERCHANGEABILITY	NIST CALIBRATION	REFERENCE
Standard		HEL-705-U-0-12-00
Optional		HEL-705-U-1-12-00
Standard		HEL-707-U-0-12-00
Optional		HEL-707-U-1-12-00
Standard		HEL-711-U-0-12-00
Optional		HEL-711-U-1-12-00
Standard		HEL-712-U-0-12-00
Optional		HEL-712-U-1-12-00
Standard		HEL-716-U-0-12-00
Optional		HEL-716-U-1-12-00
Optional	NIST @ 0 and 100 °C	HEL-716-U-1-12-C2
Standard		HEL-717-U-0-12-00
Optional		HEL-717-U-1-12-00

TD Series 2000 Ohm silicon RTD

Supply voltage: 10 Vdc
Temperature range: -40 °C to 150 °C
-40 °F to 302 °F

OPTIONS

TD4A Liquid temperature sensor

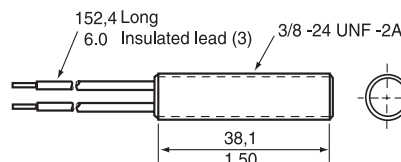

PACKAGING STYLE	TERMINATION	REFERENCE
Threaded aluminium case	Leadwires	TD4A

TD5A Subminiature temperature sensor

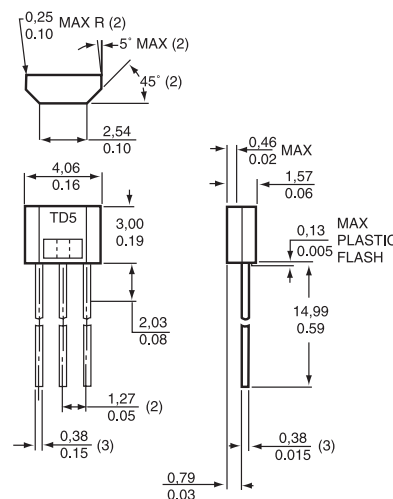

PACKAGING STYLE	TERMINATION	REFERENCE
Plastic case	SIP	TD5A

Position Sensors



SS40/400 Series Hall effect digital position sensor

SS400 Series position sensors have a thermally balanced integrated circuit over full temperature range. The negative compensation slope is optimized to match the negative temperature coefficient of lower cost magnets. Bipolar, latching and unipolar magnetics are available.

Band gap regulation provides extremely stable operation over 3.8 Vdc to 30 Vdc supply voltage range.

Package style: Radial lead IC
Supply voltage: 3.8 Vdc to 30 Vdc
Operating temperature: -40 °C to 150 °C
 -40 °F to 302 °F

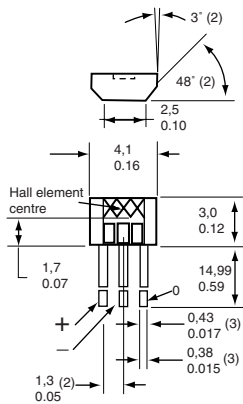

OPTIONS

MAXIMUM Operating Point and MINIMUM Release Point are specified @ 25 °C

Bipolar - temperature compensated

OPERATING POINT (MAXIMUM)	RELEASE POINT (MINIMUM)	REFERENCE
60 Gauss	-60 Gauss	SS411A
140 Gauss	-140 Gauss	SS413A

Bipolar - non temperature compensated

Supply voltage: 4.5 to 24 Vdc
Operating temperature: -55 °C to 150 °C
 -67 °F to 302 °F

OPERATING POINT (MAXIMUM)	RELEASE POINT (MINIMUM)	REFERENCE
150 Gauss	-140 Gauss	SS41

Unipolar - temperature compensated

OPERATING POINT (MAXIMUM)	RELEASE POINT (MINIMUM)	REFERENCE
115 Gauss	20 Gauss	SS441A
180 Gauss	75 Gauss	SS443A
390 Gauss	235 Gauss	SS449A

Bipolar latching- temperature compensated

OPERATING POINT (MAXIMUM)	RELEASE POINT (MINIMUM)	REFERENCE
85 Gauss	-85 Gauss	SS461A
180 Gauss	-180 Gauss	SS466A

SS49/490 Series Ratiometric hall effect linear position sensor

Package style: Radial lead IC
Supply voltage: 4.5 to 10.5 Vdc
Operating temperature: -40 °C to 150 °C
 -40 °F to 302 °F
Magnetic range: -670 to 670 Gauss

OPTIONS

Temperature compensated

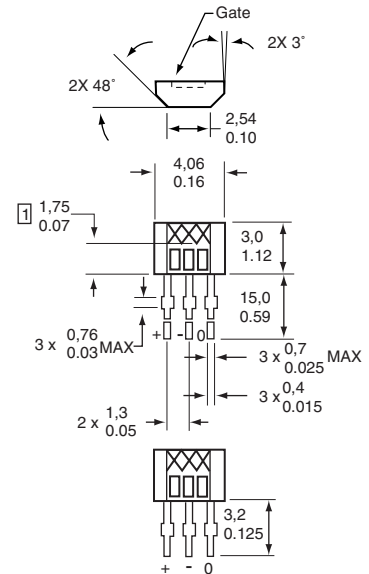

	PACKAGE STYLE	REFERENCE
		SS495A
High accuracy		SS495A1
High accuracy	Surface mount	SS495A1-S
	Surface mount reel	SS495A-SP

SS49/490 Series Ratiometric hall effect linear position sensor (Continued)

Non temperature compensated

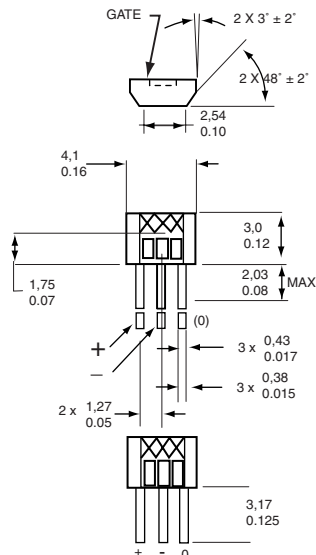

Supply voltage: 4 to 10 Vdc
Operating temperature: -25 °C to 85 °C
 -13 °F to 185 °F
Magnetic range: -1000 to 1000 Gauss

REFERENCE
SS49

Miniature Ratiometric hall effect linear position sensor

SS490 Series MRL (Miniature Ratiometric Linear) sensors have a ratiometric output voltage, set by the supply voltage. It varies in proportion to the strength of the magnetic field.

Temperature compensated

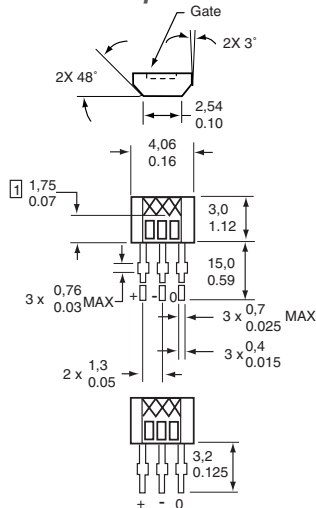

MAGNETIC RANGE REFERENCE
 -670 to 670 Gauss SS495B
 -840 to 840 Gauss SS496B

SS500 Series Hall effect digital position sensor

Package style: Surface mount
Supply voltage: 3.8 to 30 Vdc
Operating temperature: -40 °C to 150 °C
 -40 °F to 302 °F

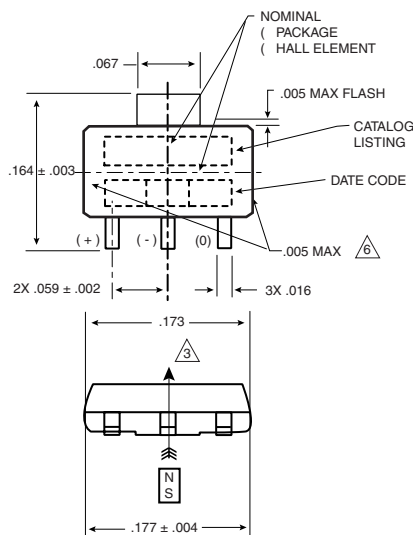

OPTIONS

MAXIMUM Operating Point and MINIMUM Release Point are specified @ 25 °C

Bipolar - temperature compensated

OPERATING POINT (MAXIMUM)	RELEASE POINT (MINIMUM)	REFERENCE
60 Gauss	-60 Gauss	SS511AT
140 Gauss	-140 Gauss	SS513AT

Bipolar - non temperature compensated

Supply voltage: 4.5 to 24 Vdc

OPERATING POINT (MAXIMUM)	RELEASE POINT (MINIMUM)	REFERENCE
140 Gauss	-140 Gauss	SS51T

Unipolar - temperature compensated

OPERATING POINT (MAXIMUM)	RELEASE POINT (MINIMUM)	REFERENCE
115 Gauss	20 Gauss	SS541AT
180 Gauss	75 Gauss	SS543AT
390 Gauss	235 Gauss	SS549AT

Bipolar latching- temperature compensated

OPERATING POINT (MAXIMUM)	RELEASE POINT (MINIMUM)	REFERENCE
85 Gauss	-85 Gauss	SS561AT
180 Gauss	-180 Gauss	SS566AT

SS94 Series Ratiometric hall effect linear position sensor

The SS9 utilizes a Hall effect integrated circuit chip which provides increased temperature stability and performance. Laser trimmed thick film resistors on the ceramic substrate and thin film resistors on the integrated circuit reduce null and gain shifts over temperature which results in consistent sensitivity from one device to the next.

Package style: Ceramic
Supply voltage: 6.6 Vdc to 12.6 Vdc
Operating temperature: -40 °C to 125 °C
 -40 °F to 257 °F
Magnetic range: -500 to 500 Gauss
 SS94A1F -100 to 100 Gauss

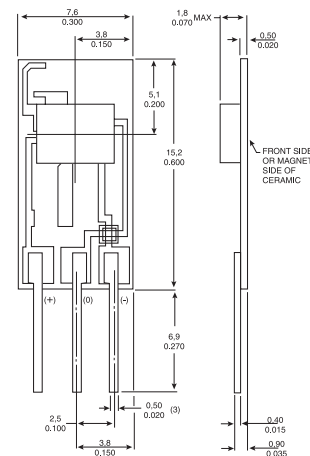

OPTIONS

Temperature compensated

MAIN FEATURE	REFERENCE
General purpose	SS94A1
High sensitivity (25 mV/Gauss output @ 8 Vdc supply)	SS94A1F
Noise shielded	SS94A2

2SS Series Magnetoresistive digital position sensor

2SS Series position sensors have magnetoresistive material integrated on silicon and encapsulated in a plastic package. The integrated circuit provides a digital output in response to very low magnetic fields. Though this signal is identical to our digital Hall effect sensors, it can be achieved by magnetoresistive sensors at much greater sensor-to-magnet distances.

Supply voltage: 3.8 Vdc to 30 Vdc
Operating temperature: -40 °C to 150 °C
-40 °F to 302 °F

Maximum operating point: 25 Gauss
Minimum release point: 5 Gauss

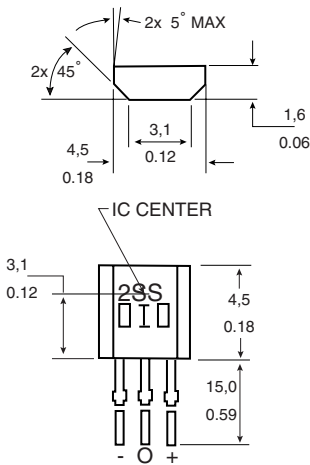

OPTIONS

Omnipolar

PACKAGE STYLE	REFERENCE
Radial lead IC	2SS52M
Surface Mount	2SS52M-S

SR13 Series Hall effect digital position sensor

SR13 series Hall-effect digital position sensors permit quick and easy sensor installation, with snap-in and flat mount sensor packages, and can house any of the present SS400 series sensors or any similarly sized sensing elements.

Package style: Plastic snap-in
Supply voltage: 3.8 Vdc to 30 Vdc
Operating temperature: -40 °C to 150 °C
-40 °F to 302 °F

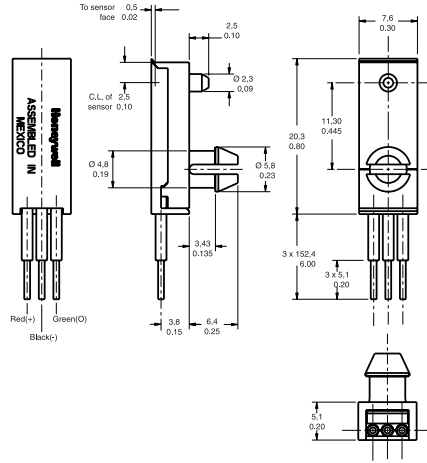

OPTIONS

MAXIMUM Operating Point and MINIMUM Release Point are specified @ 25 °C

Unipolar

OPERATING POINT (MAXIMUM)	RELEASE POINT (MINIMUM)	REFERENCE
180 Gauss	75 Gauss	SR13C-A1
115 Gauss	20 Gauss	SR13D-A1
390 Gauss	235 Gauss	SR13F-A1

Bipolar latching

OPERATING POINT (MAXIMUM)	RELEASE POINT (MINIMUM)	REFERENCE
85 Gauss	-85 Gauss	SR13R-A1

SR16 Series Cost effective digital vane sensor

SR16 series competitively priced Hall-effect digital vane sensors contain an internal magnet and Hall effect sensor mounted in a twin tower configuration.

Package style: Dual tower
Supply voltage: 3.8 Vdc to 30 Vdc
Operating temperature: -20 °C to 85 °C
-4 °F to 185 °F

OPTIONS

Type J4

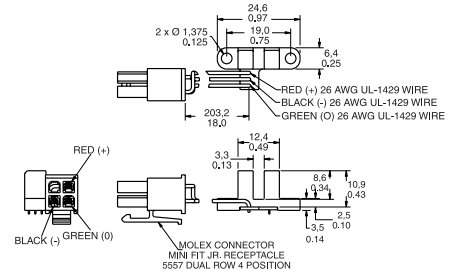

Type J6

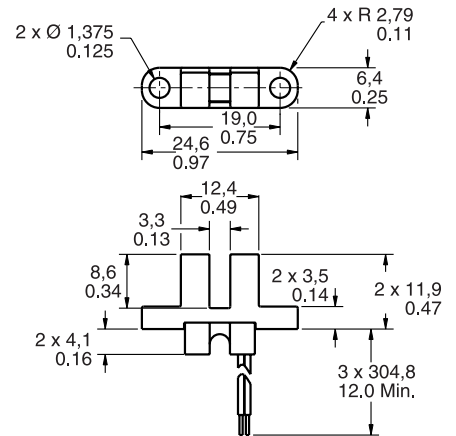

Type N

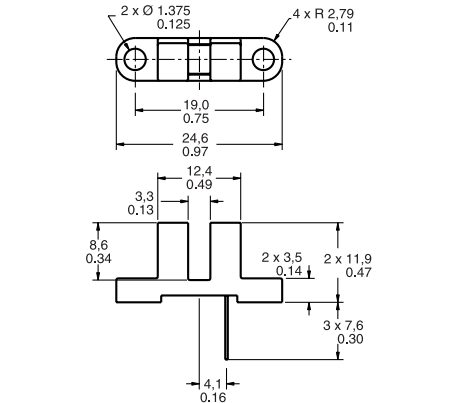

PACKAGE STYLE	REFERENCE
PCB/Molex 557 connector	SR16C-J4
Wire exit	SR16C-J6
PCB mount leads	SR16C-N

SR17 Series

Cost effective digital vane sensor

SR17 series competitively priced Hall-effect digital vane sensors are designed for position and speed sensing and are offered in a side-mount twin tower package.

Package style: Side looker mounting
Supply voltage: 3.8 Vdc to 30 Vdc
Operating temperature: -20 °C to 85 °C
 -4 °F to 185 °F

OPTIONS

Type J6

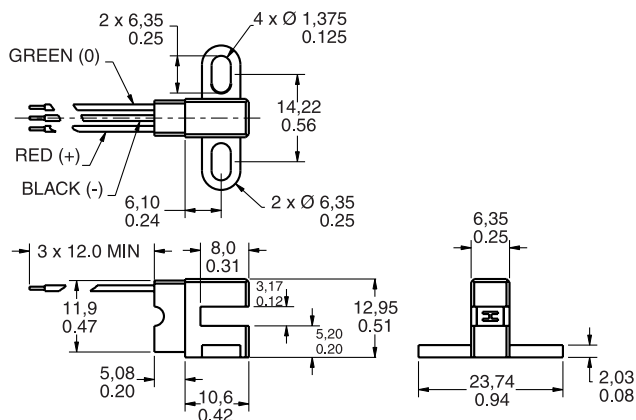

Type J7

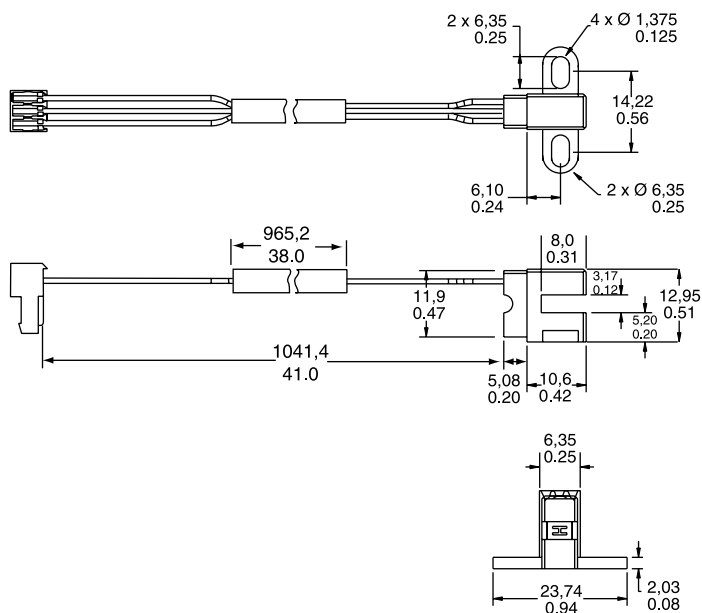

PACKAGE STYLE
 Side mount wire exit
 41 in wire leads and connector

REFERENCE
 SR17C-J6
 SR17C-J7

Infrared Products

Optoelectronics is the integration of optical principles and semi-conductor electronics. Optoelectronic components are reliable, cost effective sensors. Standard infrared emitting diodes (IREDs), sensors and assemblies are covered. Infrared sensors are used for presence sensing, motion sensing, position encoding, limit sensing, movement detection and counting.



Infrared emitting diodes

OPTIONS

Metal package, end-emitting

Coaxial, lead case - SE1450/1470(L)

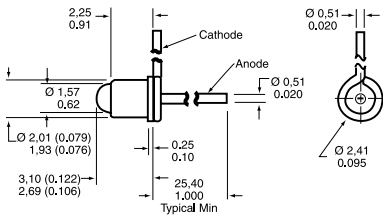

Miniature pill - SE2460/2470

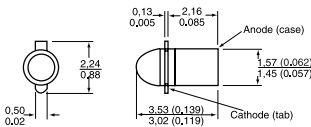

TO-46, flat window - SE3455/3470

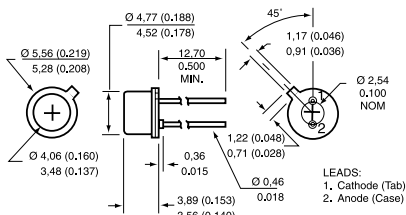

TO-46, dome lensed - SE5455/5470

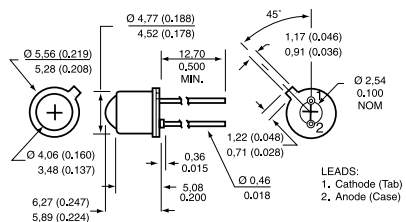

Operating temperature: -55 °C to 125 °C (-67 °F to 257 °F)

OUTPUT WAVELENGTH (nm)	BEAM ANGLE (°)	POWER OUTPUT	REFERENCE
935	24	0.70 mW min.	SE1450-003L
880	24	1.10 to 4.50 mW/cm ²	SE1470-003L
935	18	1.00 mW min.	SE2460-003
880	18	6.0 mW/sr min.	SE2470-002
935	90	5.4 mW min.	SE3455-004
880	90	10.5 mW min.	SE3470-003
935	20	4.8 mW min.	SE5455-003
880	20	3.5 mW/cm ² min.	SE5470-004

Plastic package

T1, end-emitting - SEP8505/8705

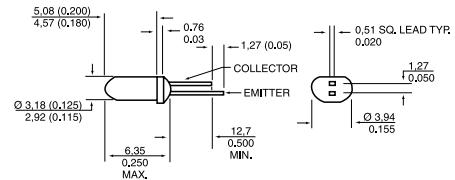

Side-emitting - SEP8506/8706

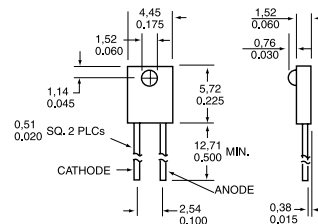

Side-emitting - SEP8736

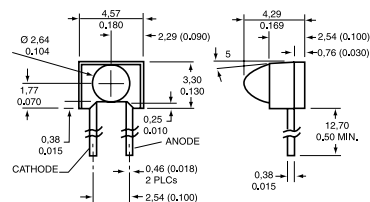

Operating temperature: -40 °C to 85 °C (-40 °F to 185 °F)

OUTPUT WAVELENGTH (nm)	BEAM ANGLE (°)	POWER OUTPUT	REFERENCE
935	15	2.0 to 4.0 mW/cm ²	SEP8505-003
935	50	0.33 to 0.52 mW/cm ²	SEP8506-002
880	15	2.7 to 7.8 mW/cm ²	SEP8705-003
880	10	1.7 to 3.0 mW/cm ²	SEP8736-003

Ceramic discrete surface mount - glass lens

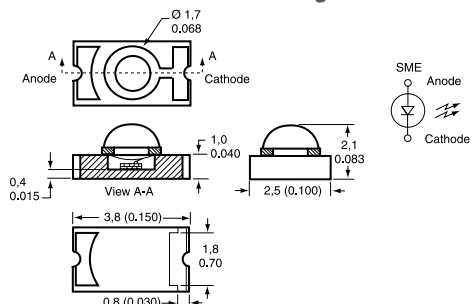

Note:

This device can be mounted with the lens up or down, looking through PCB.

Operating temperature: -55 °C to 125 °C (-67 °F to 257 °F)

OUTPUT WAVELENGTH (NM)	BEAM ANGLE (°)	POWER OUTPUT	REFERENCE
880	24	0.60 mW/cm ² min.	SME2470-021

Phototransistors

OPTIONS

Metal package

Coaxial, lead case - SD1440(L)

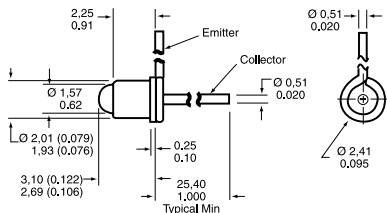

Miniature pill - SD2440

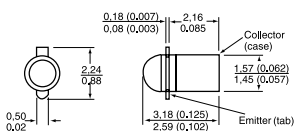

TO-46, flat window - SD3443

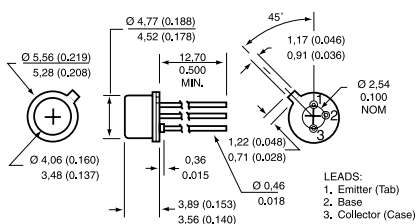

TO-46, dome lensed - SD5443

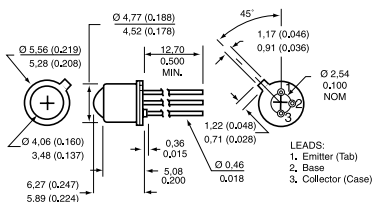

Operating temperature: -55 °C to 125 °C (-67 °F to 257 °F)

ANGULAR RESPONSE (°)	LIGHT CURRENT MINIMUM (mA)	REFERENCE
24	3.0	SD1440-003L
48	7.0	SD2440-004
90	2.0	SD3443-003
18	8.0	SD5443-003

Plastic package

T1, end-looking - SDP8405

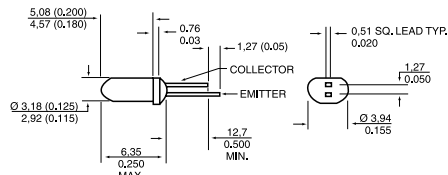

Side-looking - SDP8406

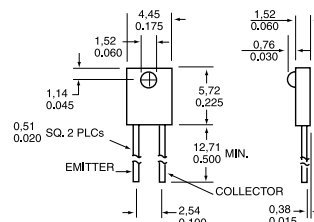

Side-looking - SDP8436

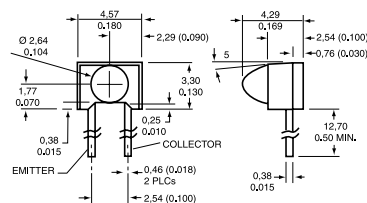

Operating temperature: -40 °C to 85 °C (-40 °F to 185 °F)

ANGULAR RESPONSE (°)	LIGHT CURRENT MINIMUM (mA)	REFERENCE
20	12.0	SDP8405-003
50	1.80	SDP8406-002
18	7.0	SDP8436-003

Ceramic discrete surface mount - glass lens

Top-looking - SMD2420/2440

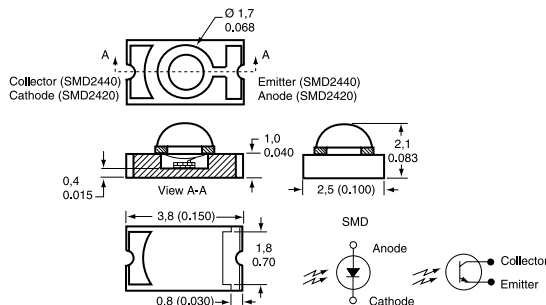

Note: This device can be mounted with the lens up or down, looking through PCB.

Operating temperature: -55 °C to 125 °C (-67 °F to 257 °F)

ANGULAR RESPONSE (°)	LIGHT CURRENT MINIMUM (mA)	REFERENCE
28	3.0	SMD2440-012

Optoschmitt detectors

OPTIONS

Metal package

TO-46, dome lensed

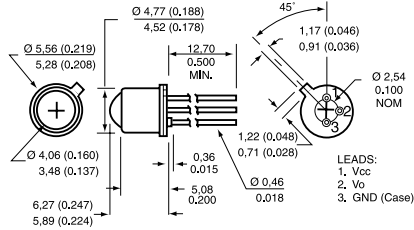

Operating temperature: -40 °C to 100 °C (-40 °F to 212 °F)
Supply voltage: 16.0 V
Output: 10 kOhm Pull-up
Angular response: 12°

OUTPUT LOGIC	TURN-ON THRESHOLD IRRADIANCE	REFERENCE
Buffer	2.5 mW/cm ² max.	SD5600-001
Inverter	2.5 mW/cm ² max.	SD5610-001
Buffer	0.25 mW/cm ²	SD5620-001
Inverter	0.25 mW/cm ²	SD5630-001

Plastic package

Side-looking

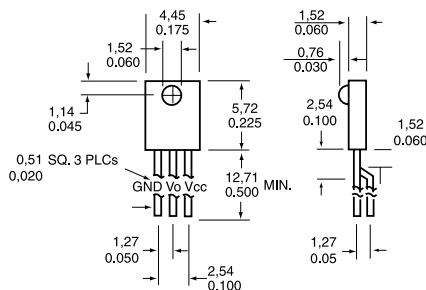

Operating temperature: -40 °C to 85 °C (-40 °F to 185 °F)
Supply voltage: 16.0 V
Output: 10 kOhm Pull-up
Angular response: 50°

OUTPUT LOGIC	TURN-ON THRESHOLD IRRADIANCE	REFERENCE
Buffer	2.5 mW/cm ² max.	SDP8600-001

Encoder sensors

Operating temperature: -40 °C to 85 °C (-40 °F to 185 °F)
Turn-on threshold irradiance: 0.05 mW/cm² to 2.0 mW/cm²
Supply voltage: 4.5 Vdc to 5.5 Vdc
Package style: Plastic, PC mount

OPTIONS

Side-looking - HLC2705

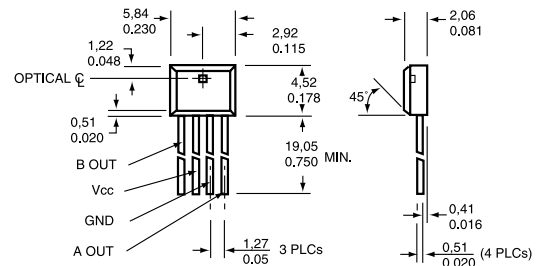

PC mount - HOA0901/0902

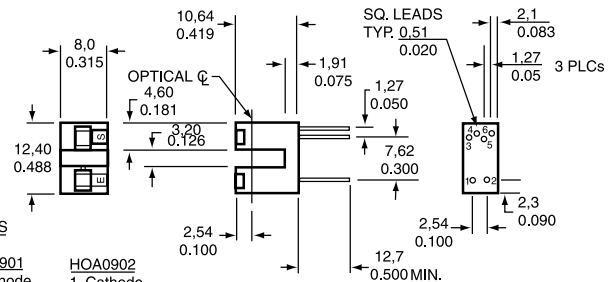

LEADS

- | | |
|----------------|----------------|
| HOA0901 | HOA0902 |
| 1. Cathode | 1. Cathode |
| 2. Anode | 2. Anode |
| 3. Output A | 3. Speed |
| 4. GND | 4. GND |
| 5. Vcc | 5. Vcc |
| 6. Output B | 6. Direction |

OUTPUT OPTION

- Speed and direction
- Direction, inverting logic
- Speed and direction, 2 tachometer

REFERENCE

- HLC2705-001
- HOA0901-011
- HOA0902-011

NOTICE

Housings are soluble in chlorinated hydrocarbons and ketones. Recommended cleaning agents are methanol and isopropanol.

Reflective sensors

OPTIONS

Metal components

Converging/focused optical axis - HOA1180

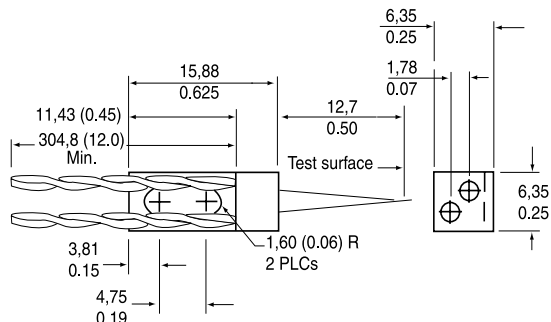

HOA Series

Converging/focused optical axis - HOA0149

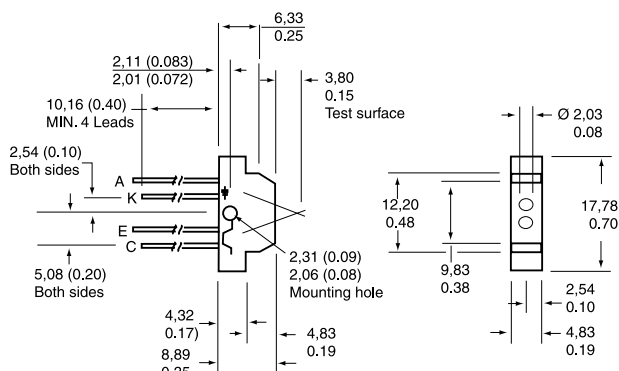

Converging/focused optical axis - HOA2498

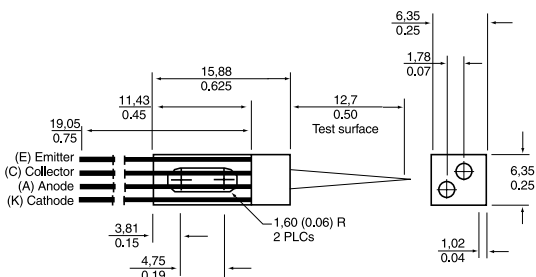

HOA1397

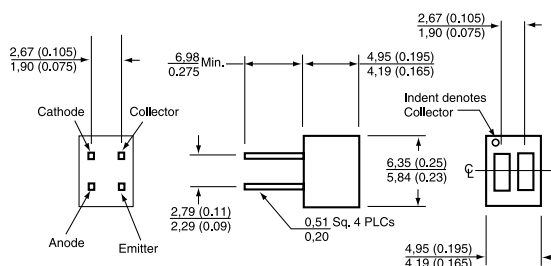

Operating temperature: -55 °C to 100 °C (-67 °F to 212 °F)
Output: Transistor

ON-STATE COLLECTOR CURRENT	REFERENCE
0.16 mA	HOA1180-002
0.16 mA	HOA2498-002

(1,27 mm/0.05 in) point of optimum response

Plastic package

HLC1395 Series, short distance detection

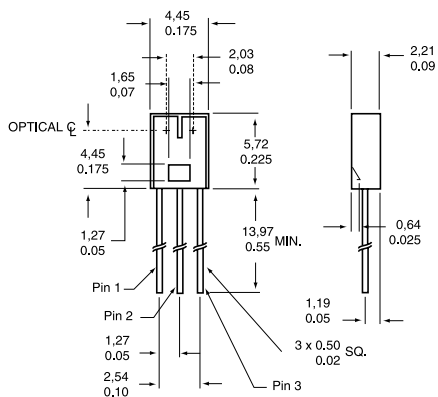

(1,0 mm/0.04 in) point of optimum response

Converging/focused optical axis - HOA1405

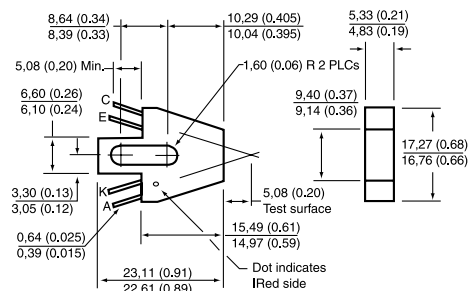

Operating temperature: -40 °C to 85 °C (-40 °F to 185 °F)
Output: Transistor

	ON-STATE COLLECTOR CURRENT	REFERENCE
Low profile	0.60 mA	HLC1395-002
	1.00 mA	HOA0149-001
	0.70 mA	HOA1397-002
	0.80 mA	HOA1405-002

NOTICE

Housings are soluble in chlorinated hydrocarbons and ketones. Recommended cleaning agents are methanol and isopropanol.

**Transmissive sensors,
Phototransistor output**

OPTIONS

Metal components

HOA1877

Aperture (emitter and detector): $\varnothing 1,27 \text{ mm}$ (0.050 in)

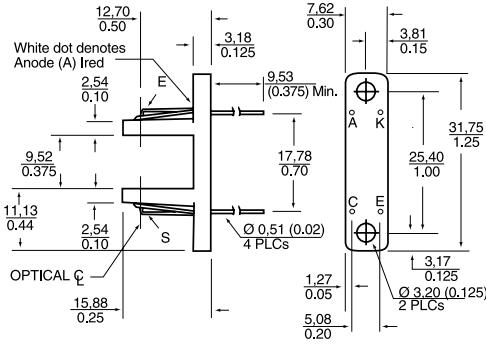

Operating temperature: $-55 \text{ }^{\circ}\text{C}$ to $100 \text{ }^{\circ}\text{C}$ ($-67 \text{ }^{\circ}\text{F}$ to $212 \text{ }^{\circ}\text{F}$)
Output: Transistor

ON-STATE COLLECTOR CURRENT	REFERENCE
0.1 mA	HOA1877-001

Plastic components

HOA086X/087X

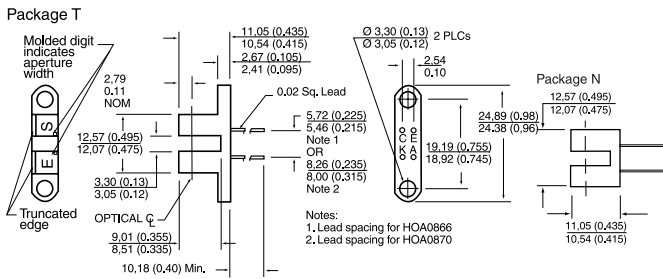

HOA1879

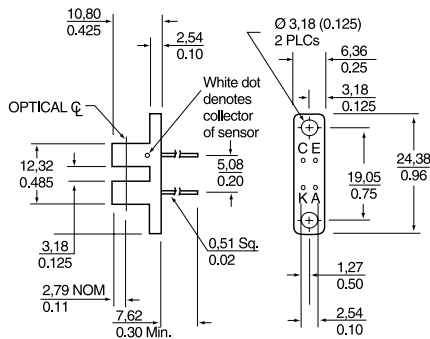

NOTICE
Housings are soluble in chlorinated hydrocarbons and ketones. Recommended cleaning agents are methanol and isopropanol.

HOA1882

Aperture (emitter and detector): $\varnothing 1,52 \text{ mm}$ (0.060 in)

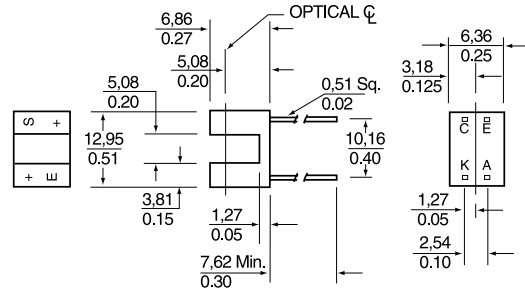

Plastic components, wire leads

HOA088X/089X

Wire colour code and functions

Red - IRED Anode
Black - IRED Cathode

White - Detector Collector
Green - Detector Emitter

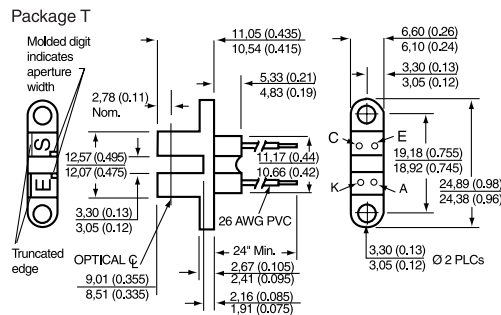

HOA1870

Wire colour code and functions:

Orange - IRED Anode
Green - IRED Cathode

White - Detector Collector
Blue - Detector Emitter

Aperture (emitter and detector): $0,15 \text{ mm}$ (0.006 in) wide

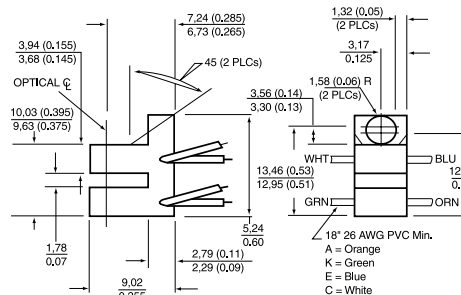

Operating temperature: $-40 \text{ }^{\circ}\text{C}$ to $85 \text{ }^{\circ}\text{C}$ ($-40 \text{ }^{\circ}\text{F}$ to $185 \text{ }^{\circ}\text{F}$)
Output: Transistor

	ON-STATE COLLECTOR CURRENT	REFERENCE
Opaque housing	1.00 mA	HOA0866-T55
	0.50 mA	HOA0870-N51
	0.50 mA	HOA0880-P51
Opaque housing	0.50 mA	HOA0890-L55
	0.30 mA	HOA1870-031
	0.50 mA	HOA1879-015
	1.80 mA	HOA1882-012

Transmissive sensors, Optoschmitt output

OPTIONS

Plastic components

HOA096X/097X
HOA696X/697X

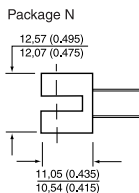
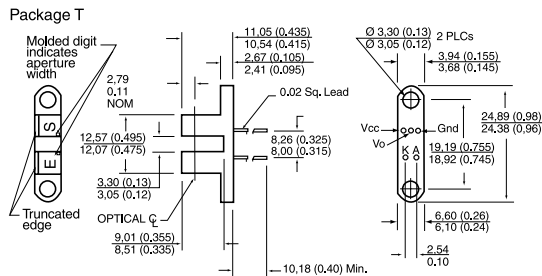

Plastic components, integral 3 pin connector HOA7720/30

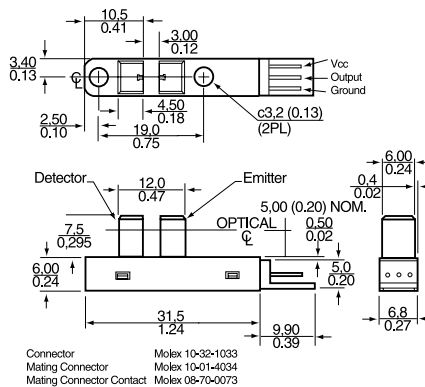

Operating temperature: -40 °C to 70 °C (-40 °F to 158 °F)

	OUTPUT	OUTPUT LOGIC	HYSTERESIS	REFERENCE
Opaque housing	10 kOhm Pull-up	Buffer	10 %	HOA0961-N51
	10 kOhm Pull-up	Buffer	10 %	HOA0971-N51
Opaque housing	Open-Collector	Inverter	5 %	HOA6963-N51
	Totem-Pole	Inverter	5 %	HOA6972-N55
Opaque housing	Open-Collector	Buffer	5 %	HOA6981-L51
	Totem-Pole	Buffer	5 %	HOA6990-T51
Opaque housing	Totem-Pole	Inverter	5 %	HOA7720-M22
	Open-Collector	Inverter	5 %	HOA7730-M22

Plastic components, wire leads

HOA698X/699X

Wire colour code and functions:

Red - IRED Anode
Black - IRED Cathode
Green - Detector Ground
White - Detector Vcc
Blue - Detector Output

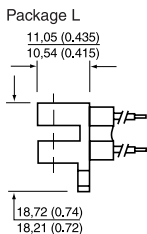
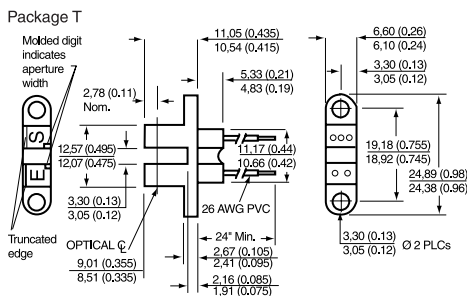

NOTICE
Housings are soluble in chlorinated hydrocarbons and ketones. Recommended cleaning agents are methanol and isopropanol.

Current Sensors

Current sensors monitor ac or dc current. Included are adjustable linear, null balance, digital, and linear current sensors.

Digital current sensors can sound an alarm, start a motor, open a valve or shut down a pump. The linear signal duplicates the waveform of the current being sensed, and can be used as a feedback element to control a motor or regulate the amount of work being done by a machine.

CSN Series Closed Loop Current Sensors



Closed loop current sensors measure ac, dc and impulse currents over 0-25, 0-50, 0-100, 0-600 and 0-1200 Amp ranges. The CSN series is based on the Hall effect principle and the null balance or zero magnetic flux method (feedback system). The magnetic flux in the sensor core is constantly controlled at zero. The amount of current required to balance zero flux is the measure of the primary current flowing through the conductor, multiplied by the ratio of the primary to secondary windings. This closed loop current is the output from the device and presents an image of the primary current reduced by the number of secondary turns at any time. This current can be expressed as a voltage by passing it through a resistor.

The CSN Series has a high overload capacity, a high level of electrical insulation between primary and secondary circuits and a rapid response rate. Lightweight and compact, and with no restriction on input current waveform, the sensors are ideal for variable speed drives, power supplies, feedback control systems, robotics/welding equipment and general overcurrent protection.

Sensed current type:	ac or dc
EMC:	EN 50082-2, EN 50081-2
Accuracy:	± 0.5 %

OPTIONS

Multi turn PCB mounted

Housing material:
Mounting:

Bayblend KU2-1468 (UL94-V0)
PCB on 13 pins

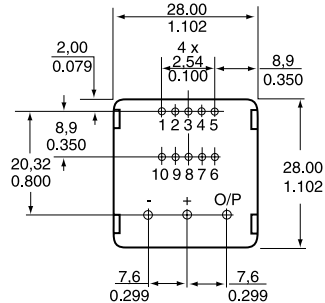

SENSED CURRENT RANGE	COIL TURNS	SUPPLY VOLTAGE	REFERENCE
± 36 A	1000 (110 Ohm coil)	± 15 Vdc	CSNE151

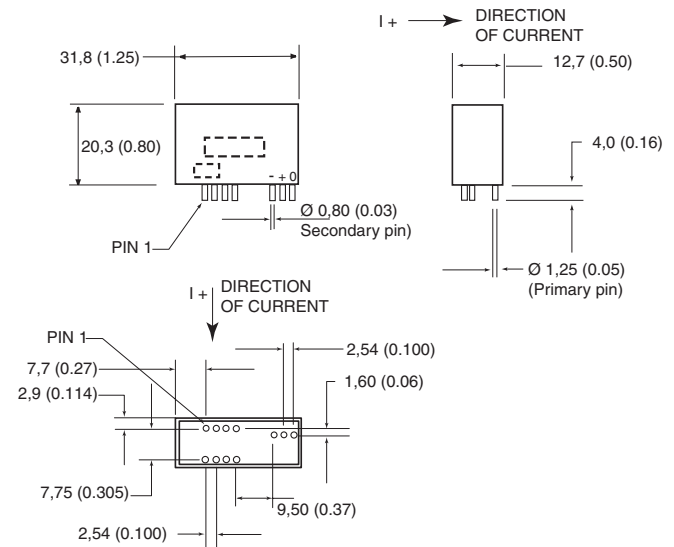

SENSED CURRENT RANGE	NOMINAL CURRENT	COIL TURNS	SUPPLY VOLTAGE	REFERENCE
± 90 A	25 A	1000 (66 Ohm coil)	± 12 Vdc to 15 Vdc	CSNE151-100
± 90 A	50 A	1000 (66 Ohm coil)	± 12 Vdc to 15 Vdc	CSNE151-200

Small housed style

Housing material:
Mounting:

Bayblend FR 1440 (UL94-V0)
PCB on 3 pins

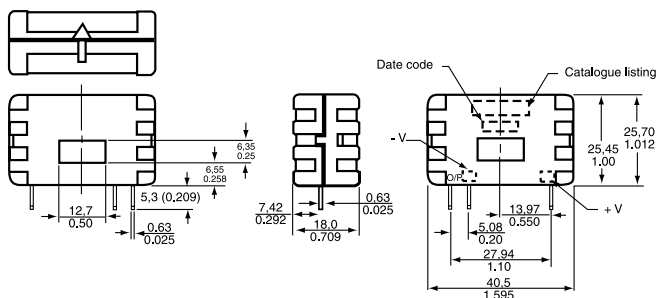

SENSED CURRENT RANGE	COIL TURNS	SUPPLY VOLTAGE	REFERENCE
± 70 A	1000 (90 Ohm coil)	± 15 Vdc	CSNA111
± 90 A	1000 (50 Ohm coil)	± 13 Vdc	CSNC241-500
± 100 A	2000 (160 Ohm coil)	± 15 Vdc	CSNB121
± 100 A	2000 (130 Ohm coil)	± 15 Vdc	CSNB131

Small housed family

Housing material:
Mounting:

Bayblend KU2-1468 (UL94-V0)
PCB on 3 pins

Pinout style 'A'

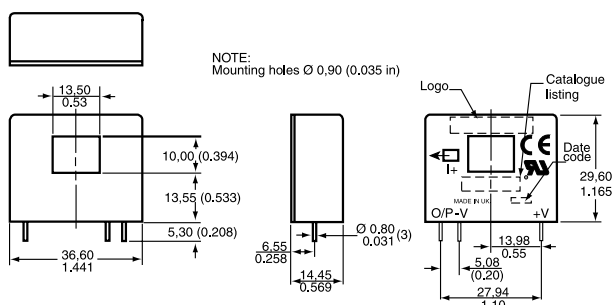

SENSED CURRENT RANGE	COIL TURNS	SUPPLY VOLTAGE	REFERENCE
± 90 A	1000 (30 Ohm coil)	± 12 to ± 15 Vdc	CSNP661
± 150 A	2000 (100 Ohm coil)	± 12 to ± 15 Vdc	CSNT651
± 180 A	2000 (100 Ohm coil)	± 15 Vdc	CSNG251

Pinout style 'B'

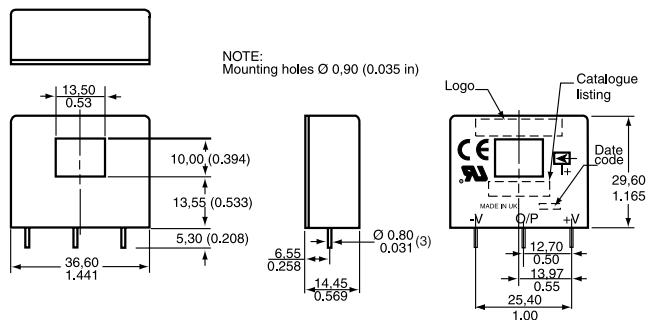

SENSED CURRENT RANGE	COIL TURNS	SUPPLY VOLTAGE	REFERENCE
± 150 A	1000 (30 Ohm coil)	± 12 to ± 15 Vdc	CSNF161
± 180 A	2000 (100 Ohm coil)	± 12 to ± 15 Vdc	CSNF151
± 200 A	2000 (100 Ohm coil)	± 12 to ± 15 Vdc	CSNR151
± 200 A	1000 (30 Ohm coil)	± 12 to ± 15 Vdc	CSNR161

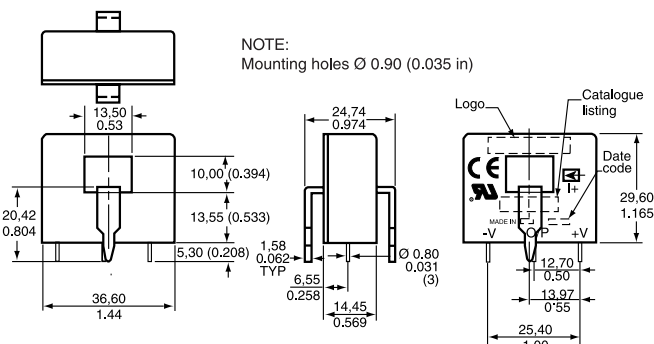

SENSED CURRENT RANGE	COIL TURNS	SUPPLY VOLTAGE	REFERENCE
± 150 A	1000 (30 Ohm coil)	± 12 to ± 15 Vdc	CSNF161-002
± 200 A	2000 (100 Ohm coil)	± 12 to ± 15 Vdc	CSNR151-002
± 200 A	1000 (30 Ohm coil)	± 12 to ± 15 Vdc	CSNR161-002

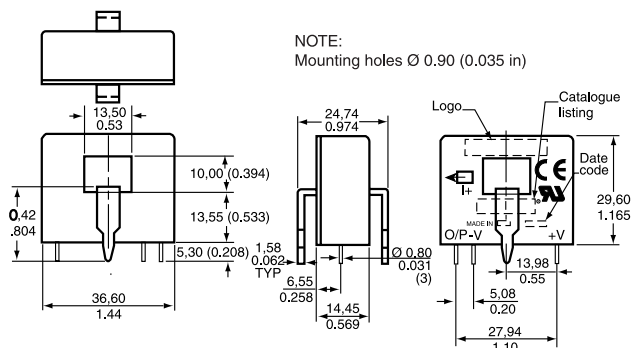

SENSED CURRENT RANGE	COIL TURNS	SUPPLY VOLTAGE	REFERENCE
± 90 A	1000 (30 Ohm coil)	± 12 to ± 15 Vdc	CSNP661-002
± 150 A	2000 (100 Ohm coil)	± 12 to ± 15 Vdc	CSNT651-001

CSN Series Closed Loop Current Sensors (Continued)

Mid range housed style

Housing material:
Mounting:

Bayblend KU2-1468 (UL94-V0)
Panel, spade terminals x 3

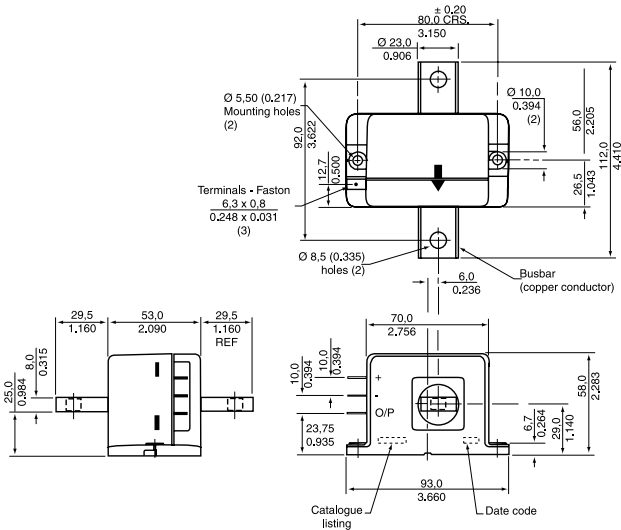

SENSED CURRENT RANGE	COIL TURNS	SUPPLY VOLTAGE	REFERENCE
± 600 A	2000 (25 Ohm coil)	± 12 to ± 18 Vdc	CSNJ481
± 600 A (fitted with busbar)	2000 (25 Ohm coil)	± 12 to ± 18 Vdc	CSNJ481-001

Large housed style

Housing material:
Mounting:

Bayblend KU2-1468 (UL94-V0)
Panel, spade terminals x 3

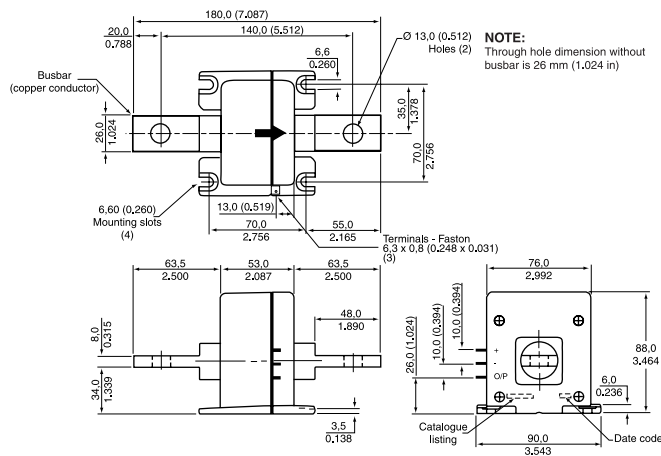

SENSED CURRENT RANGE	COIL TURNS	SUPPLY VOLTAGE	REFERENCE
± 1200 A	5000 (50 Ohm coil)	± 15 to ± 24 Vdc	CSNK591
± 1200 A (fitted with busbar)	5000 (50 Ohm coil)	± 15 to ± 24 Vdc	CSNK591-001

CSLA Series Open Loop Current Sensors

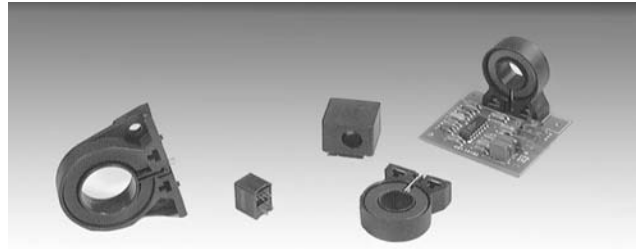

CS series linear current sensors incorporate our 91SS12-2 and SS94A1 linear output Hall effect transducer (LOHET™). These sensors cover measuring ranges from 0-950 Amps. The sensing element is assembled in a printed circuit board mountable housing. This housing is available in four configurations. Normal mounting is with 0.375 inch long 4-40 screw and square nut (not provided) inserted in the housing or a 6-20 self-tapping screw. The combination of the sensor, flux collector, and housing comprises the holder assembly. These sensors are ratiometric.

Sensed current type: ac or dc
Housing: PBT Polyester

OPTIONS

PCB bottom mount

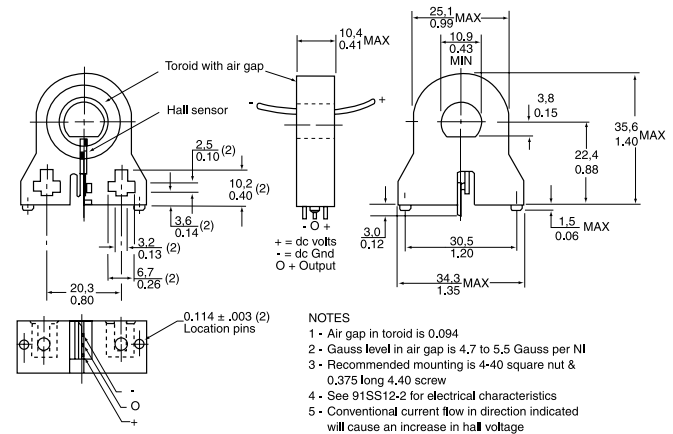

SENSED CURRENT RANGE	SUPPLY VOLTAGE	REFERENCE
0 to 75 A	8 to 16 Vdc	CSLA1DE
0 to 92 A	6 to 12 Vdc	CSLA2DE
0 to 150 A	6 to 12 Vdc	CSLA2DG
0 to 225 A	8 to 16 Vdc	CSLA1DJ
0 to 225 A	6 to 12 Vdc	CSLA2DJ
0 to 325 A	8 to 16 Vdc	CSLA1DK
0 to 400 A	6 to 12 Vdc	CSLA2DK

PCB bottom mount

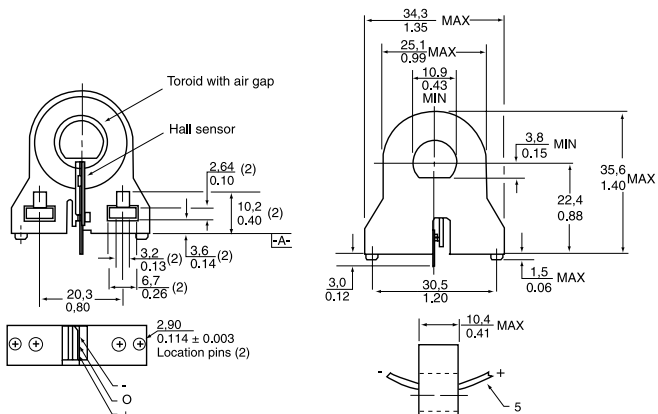

NOTES

- 1 - Air gap in toroid is 1.90 (0.075)
- 2 - Gauss level in air gap is 6.0 to 7.0 Gauss per NI
- 3 - Recommended mounting is 4-40 square nut & 0.375 long 4.40 screw
- 4 - See 91SS12-2 for electrical characteristics
- 5 - Conventional current flow in direction indicated will cause an increase in hall voltage

SENSED CURRENT RANGE	SUPPLY VOLTAGE	REFERENCE
0 to 57 A	8 to 16 Vdc	CSLA1CD
0 to 72 A	6 to 12 Vdc	CSLA2CD
0 to 100 A	8 to 16 Vdc	CSLA1CF
0 to 150 A	8 to 16 Vdc	CSLA1CH

PCB bottom mount

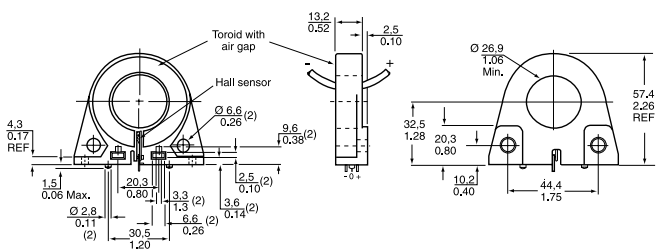

SENSED CURRENT RANGE	SUPPLY VOLTAGE	REFERENCE
0 to 310 A	6 to 12 Vdc	CSLA2EJ
0 to 550 A	6 to 12 Vdc	CSLA2EL
0 to 625 A	8 to 16 Vdc	CSLA1EL
0 to 765 A	6 to 12 Vdc	CSLA2EM
0 to 950 A	6 to 12 Vdc	CSLA2EN

PCB side mount

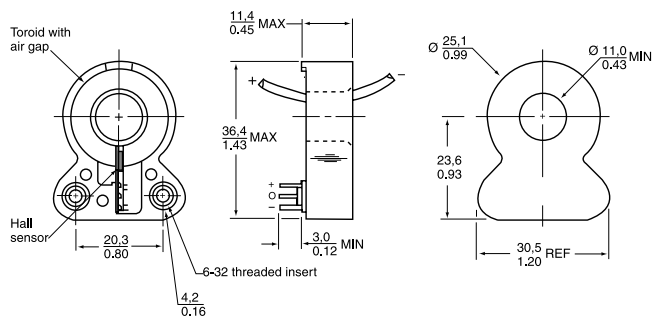

SENSED CURRENT RANGE	SUPPLY VOLTAGE	REFERENCE
0 to 57 A	8 to 16 Vdc	CSLA1GD
0 to 72 A	6 to 12 Vdc	CSLA2GD

PCB side mount

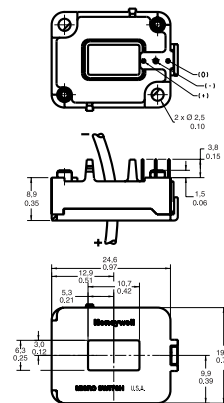

SENSED CURRENT RANGE	SUPPLY VOLTAGE	REFERENCE
± 45 A	4.5 to 10.5 Vdc	CSLH3A45

Digital current sensor

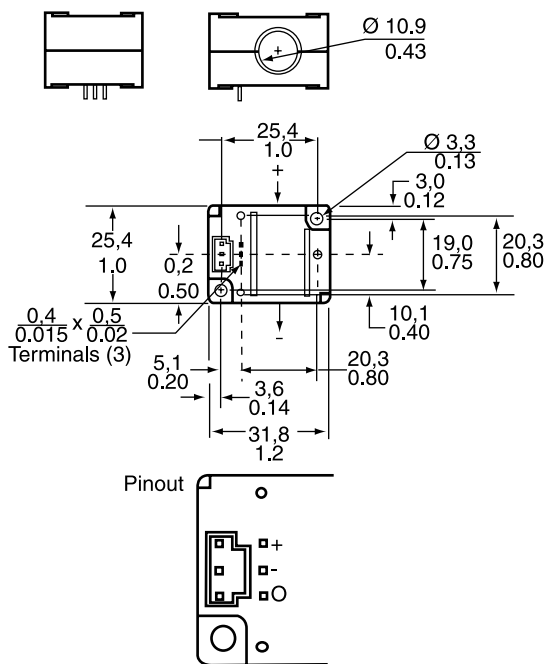

OPERATE CURRENT	SUPPLY VOLTAGE	REFERENCE
3.5 A.t Nominal	6 to 16 Vdc	CSDA1BC

Liquid Level Sensors



Honeywell liquid level sensor components incorporate a voltage level switch which provides a digital output that denotes the presence or absence of liquid.

The mode of operation is derived from the principle of total internal reflection. An LED and detector are housed within a plastic dome at the head of the device. When no liquid is present, all light from the LED is totally internally reflected from the dome boundary to the detector. When liquid covers the dome, the effective refractive index at the dome/liquid boundary changes, allowing some light from the LED to escape. Thus the amount of light received by the voltage level switch is reduced and the output switches, denoting the presence of liquid. This method of liquid level sensing is very fast, and instantaneous for water.

The LL Series is a basic component which requires external circuit protection; this protection is incorporated in the LLE Series.

Housing:
Termination:
Supply voltage:
Pressure range:

Polysulphone
 250 mm lead wires
 +5 Vdc
 0 to 5 bar

LL Series

Operating temperature:
 Standard -20 °C to 85 °C
 -4 °F to 185 °F
 High temperature -40 °C to 125 °C
 -40 °F to 257 °F

Storage temperature:
 Standard -40 °C to 100 °C
 -40 °F to 212 °F
 High temperature -50 °C to 150 °C
 -58 °F to 302 °F

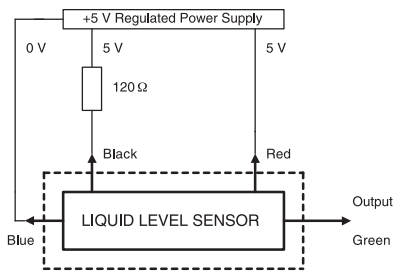

Liquid Level Sensor - LL Series

Type 5

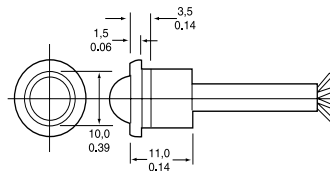

	SEAL WASHER	REFERENCE
High temperature	Nitrile rubber	LL105100

LLE Series

Operating temperature: -25 °C to 80 °C
 -13 °F to 176 °F

Storage temperature: -30 °C to 85 °C
 -22 °F to 185 °F

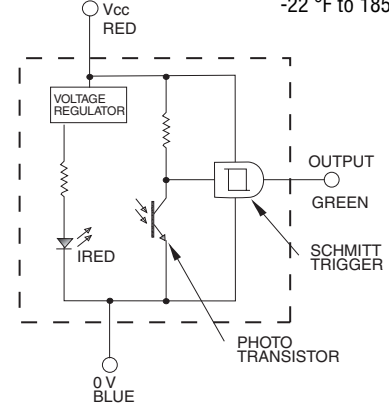

OPTIONS

Type 2

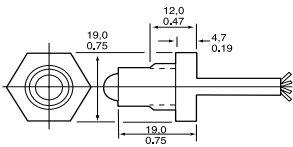

	SEAL WASHER	REFERENCE
High temperature	Vamac	LL102101

Type 3

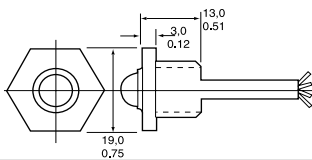

	SEAL WASHER	REFERENCE
Standard	Nitrile rubber	LL103000
High temperature	Vamac	LL103101

OPTIONS

Type 2

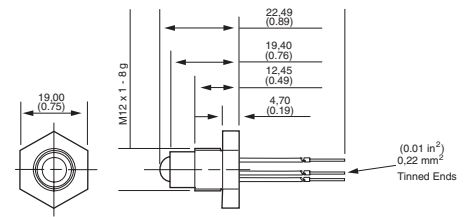

SEAL WASHER	REFERENCE
Nitrile rubber	LLE102000

Type 5

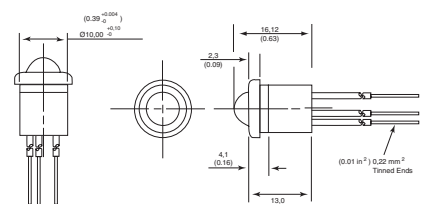

SEAL WASHER	REFERENCE
Nitrile rubber	LLE105000

Basic Switches



These listings include standard size basics, miniature, subminiature, switches. The precision snap-action mechanisms are offered with a wide variety of actuators and operating characteristics. Basic switches are ideal for applications requiring compactness, light weight, accurate repeatability and long life.

They are best used for presence/absence detection where physical contact with object is permissible. Very economical.

BA/BE/BZ Series Basic Switches

BA/BE/BZ Series Standard Basic Switches are used for simple or precision on/off application needs.

As well as the catalogue listings presented here, we offer other versions with higher temperature ratings, different termination options, different electrical ratings and Single Pole, Single Throw (SPST) circuitry. Refer to our website for details.

Voltage: 250 Vac
Electrical rating: 16 A
Operating temperature: -55 °C to 85 °C
 -67 ° F to 185 ° F

Termination: Screw
Contact type: Silver
Approvals: CE, CSA, UL
Switching options: SPDT

Single Pole, Double Throw



OPTIONS

Note: BA/BE plunger position distance from mounting hole = 19 mm (0.75 in)

Top pin plunger

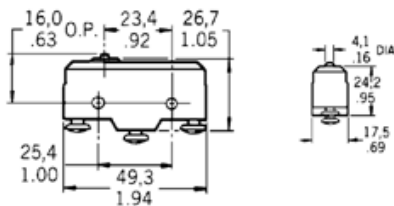

Approvals: BE-2R-A4 CSA, UL

ELECTRICAL RATING	TERMINATION	REFERENCE
25 A	Solder	BZ-R
	Screw	BZ-R-A2
	Solder	BZ-R169
	Screw	BZ-2R-A2
	Screw	BE-2R-A4

Overtravel plunger - standard

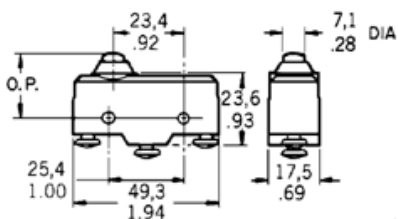

ELECTRICAL RATING	REFERENCE
20 A	BZ-2RD-A2 BA-2RB-A2

Panel mount overtravel plunger

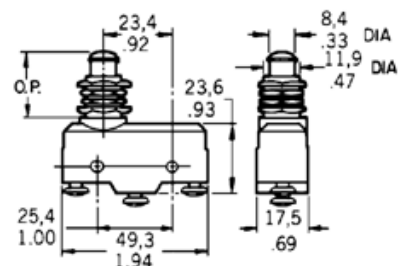

ELECTRICAL RATING	APPROVALS	REFERENCE
20 A	DEMKO	BZ-2RQ1-A2 BA-2RQ1-A2

Overtravel plunger (splash resistant)

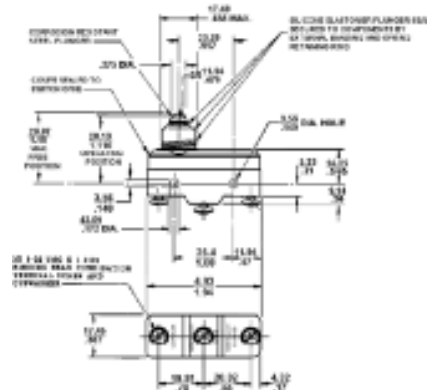

REFERENCE
BZ-2RDS-A2 BZ-2RDS-A2S

Stainless steel spring

Overtravel roller plunger

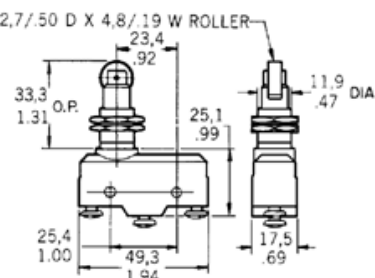

REFERENCE
BZ-2RQ18-A2

**BA/BE/BZ Series
Basic Switches
(Continued)**

*Overtravel roller plunger,
perpendicular*

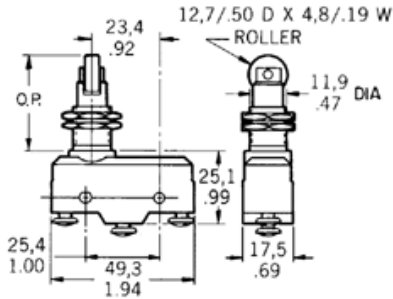

REFERENCE
BZ-2RQ181-A2

Straight lever

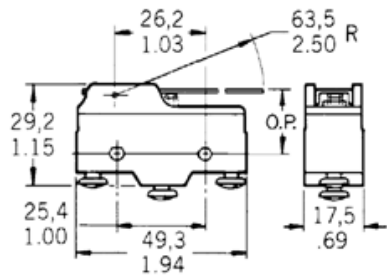

ELECTRICAL RATING	APPROVALS	LEVER RADIUS	REFERENCE
20 A	DEMKO	No return spring 152.4 mm	BA-2RV-A2 BZ-2RW80-A2 BZ-2RW84-A2 BZ-2RW863-A2

Roller lever

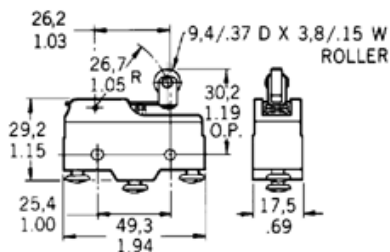

TERMINATION	LEVER RADIUS	REFERENCE
Solder		BZ-2RW822-A2 BZ-2RW822
Splash resistant	One way, 32.1 mm 48.3 mm	BZ-2RW8225551-A2 BZ-2RW826-A2 BZ-2RW82-A2

DT Series Basic Switch

DT Series Standard Basic Switches consist of two independent single-pole double throw circuits in one housing actuated by one actuator. The terminals are separated by a non-conductive shield to reduce shorting.

Voltage: 250 Vac
Electrical rating: 10 A
Operating temperature: -55 °C to 85 °C
-67 ° F to 185 °F

Termination: Screw
Contact type: Silver
Approvals: CSA, UL
Switching options: DPDT
Double Pole, Double Throw

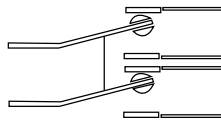

OPTIONS

Top pin plunger

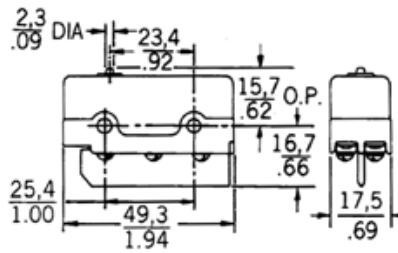

REFERENCE
DT-2R-A7

Basic Switch Accessories

A range of accessories is available for BA, BE, BZ and DT switches, such as the 5PA2 terminal enclosure. For more information please contact your local sales office.

REFERENCE
1TB1-2

**TB Series
Miniature Double-break
Basic Switch**

TB Series Miniature Double-break Basic Switches are basic double-break units that offer a means of controlling isolated circuits. Each circuit may be driven by an independent voltage source.

Voltage: 250 Vac
Electrical rating: 10 A
Operating temperature: -55 °C to 125 °C
-67 ° F to 257 °F

Termination: Solder
Contact type: Silver
Approvals: CSA, UL
Switching options: (SPDT DB)
Single Pole, Double Throw, Double Break

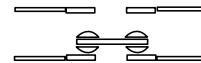

OPTIONS

Top pin plunger

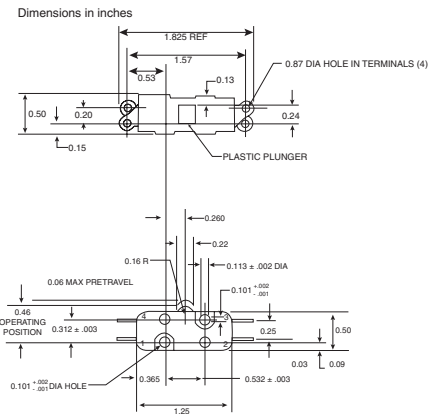

NOTE:
1 - TERMINALS 1 & 2 NORMALLY CLOSED CIRCUIT
2 - TERMINALS 3 & 4 NORMALLY OPEN CIRCUIT
3 - TERMINALS ARE PLATED FOR SOLDERING

SM and SX Series Subminiature Basic Switches

SM and SX Series Subminiature Basic Switches are used for simple or precision on/off application needs. These switches combine small size and light weight with ample electrical capacity, precision operation and long life. The SX Series are small, precision, snap-action switches that are ideal where savings in space and weight are important.

Voltage: 250 Vac
Operating temperature: -55 °C to 125 °C
-67 °F to 257 °F

Termination: Solder
Contact type: Silver
Switching options: SPDT
Single Pole, Double Throw

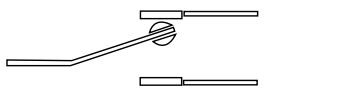

SM Series

Approvals: CE, CSA, UL
Ampere rating: 5 A

OPTIONS

Top pin plunger

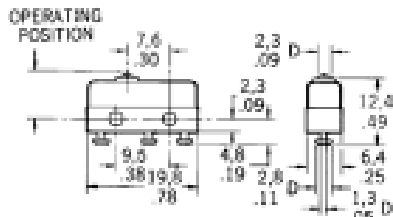

Approvals: 11SM601-H4 UL, CSA

TERMINATION	REFERENCE
Quick connect	11SM601-H4

Straight lever

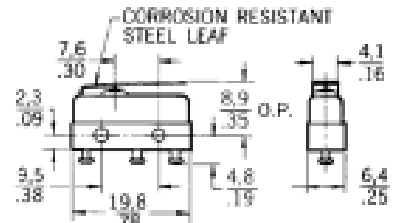

REFERENCE
111SM1
Lever length 4.83 mm

Roller lever

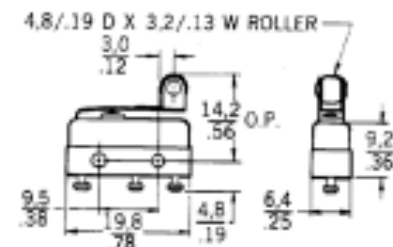

REFERENCE
111SM2-T

SX Series

Approvals: CE, CSA, UL
Ampere rating: 5 A

OPTIONS

Top pin plunger

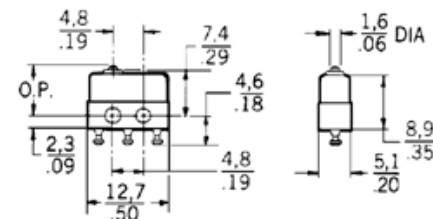

Approvals: 6SX7-T UL, CSA

CONTACTS	AMPERE RATING	REFERENCE
Silver	7 A	1SX1-T
Silver	3 A	11SX1-T
Gold	1 A	6SX7-T

Straight lever

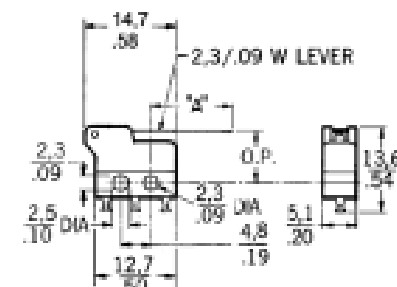

REFERENCE
311SX2-T
311SX3-T
Lever length 'A' 12.8 mm
Lever length 'A' 24.5 mm

Simulated roller

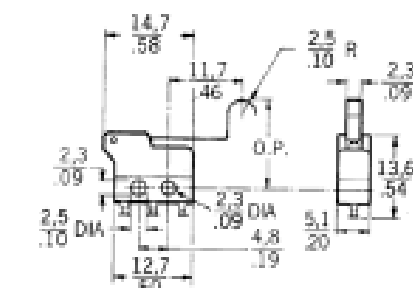

REFERENCE
311SX5-T

V5 Series Miniature Basic Switches

V5 Series Basic Switches are used for simple or precision on/off, end of limit, presence/absence, pressure, temperature and manual operator interface application needs.

Voltage:	250 Vac
Operating temperature:	Standard -55 °C to 85 °C -67 °F to 185 °F
High temperature	-55 °C to 150 °C -67 °F to 302 °F
Termination:	6,3 mm x 0,8 mm Quick connect (QC)
Contact type:	Silver/silver cadmium oxide
Electrical rating:	V5A 20 A V5B/P/R 16 A V5C/D 10 A V5S 22 A
Switching options:	SPDT Single Pole Double Throw

OPTIONS

Top pin plunger

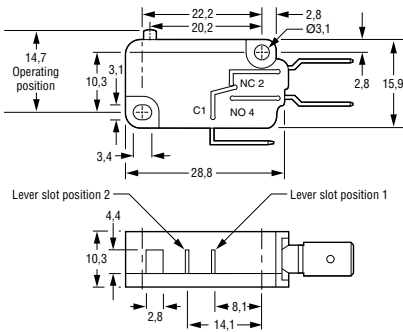

APPROVALS	REFERENCE
CE, ENEC	V5A010CB
CE, CSA, ENEC, UL	V5B010CB3
CE, CSA, UL	4,8 mm x 0,5 mm QC V5B010FB3
CE, ENEC	Solder terminals V5B010TB
CE, ENEC	High temperature V5B210CB
CE, ENEC	V5C010BB
CE, CSA, ENEC, UL	4,8 mm x 0,5 mm QC V5C010EB3
CE, CSA, ENEC, UL	Solder terminals V5C010TB3
CE, ENEC	V5P010CB

APPROVALS	SWITCHING OPTIONS	REFERENCE
CE, ENEC	SPNO	V5D030BB
CE, ENEC	SPNO	V5R030CB
CE, BEAB	SPNC	V5S020CB
CE, BEAB	SPNO	V5S030CB

Straight lever Type B

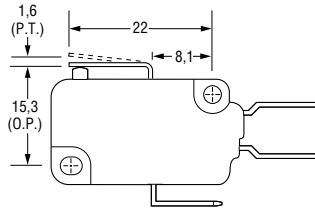

APPROVALS	REFERENCE
CE, CSA, ENEC, UL	V5C010BB3B

Type C

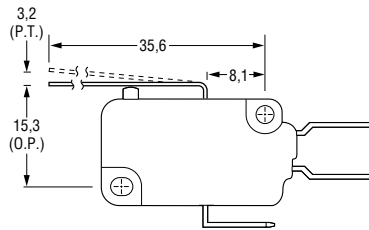

APPROVALS	REFERENCE
CE, ENEC	High temperature V5B210CB1C

Type G

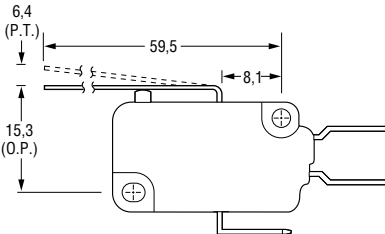

APPROVALS	REFERENCE
CE, ENEC	V5C010BB1G

Roller lever Type D

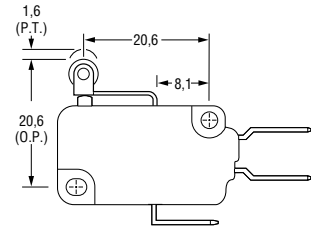

APPROVALS	REFERENCE
CE, CSA, ENEC, UL	High temperature V5B210CB3D
CE, CSA, ENEC, UL	V5C010BB3D

Type E

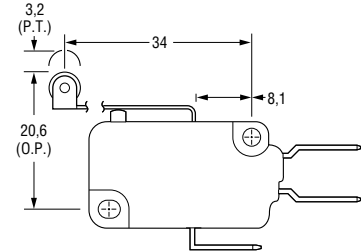

APPROVALS	REFERENCE
CE, CSA, ENEC, UL	Lever position 2 V5A010CB4E
CE, ENEC	High temperature V5B210CB1E

V7 Series Miniature Basic Switches

V5 and V7 Series Basic Switches are used for simple or precision on/off, end of limit, presence/absence, pressure, temperature and manual operator interface application needs.

The V7 Series also offers listings with Single Pole, Single Throw circuitry (available in either normally open (NO) or normally closed (NC) configurations). Refer to our website for details.

Operating temperature:

Standard -40 °C to 82 °C
 -40 °F to 180 °F
 High temperature -40 °C to 200 °C
 -40 °F to 350 °F

Termination: Quick connect (QC)
 D8, E8 - 4,8 mm (0.187 in) x 0.5 mm (0.02 in)
 E9 - 6,35 mm (0.25 in) x 0,80 mm (0.032 in)
 Printed circuit board (PCB)

Electrical rating	Contact Type
V7-*A 5 A	Silver
V7-*B 11 A	Silver
V7-*C/W 15 A	Silver
V7-*D 1 A	Gold alloy
V7-*E 10 A	Silver
V7-*S 100 mA	Gold alloy
V7-*V 21 A	Silver alloy
V7-*Z 25 A	Silver cadmium oxide

Approvals: CSA, UL, ENEC
 V7-*C/D/W CSA, UL
Switching options: SPDT

Single Pole Double Throw

AVAILABLE TERMINALS

Quick Connect (QC)

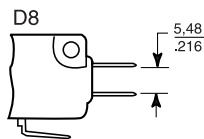

D8 terminals are European approved when used with electrical ratings A, B, D, E or S. International approving agencies require that switches with these terminals have insulated receptacles or connector.

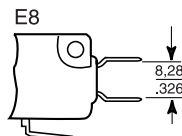

E8 terminals are European approved when used with electrical ratings A, B, D, E or S.

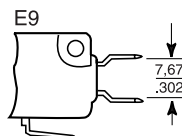

E9 terminals are European approved when used with electrical ratings A, B, D, E, S, V or Z.

Printed circuit board (P02)

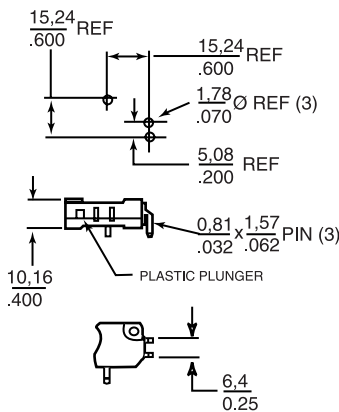

These terminals interface with snap-on receptacles and other components from AMPNODU interconnection system.

PCB terminals are European approved when used with electrical ratings A, B, D, E, S.

OPTIONS

Top pin plunger

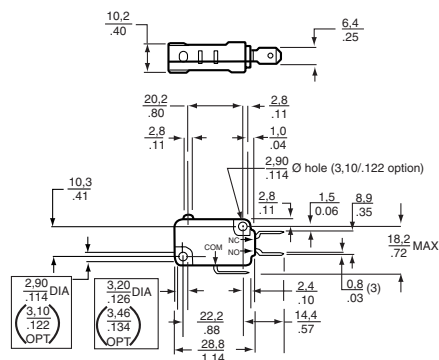

Note: The optional mounting hole dimensions shown above are standard on V5/V7 International Series switches.

VOLTAGE	TERMINATION	REFERENCE
250 Vac		V7-1A17D8
250 Vac	PCB	V7-1A17P02
250 Vac		V7-1B17D8
250 Vac		V7-1B19E9
250 Vac		V7-1C17D8
277 Vac		V7-1C17E9
277 Vac		V7-1C18E9
125 Vac		V7-1D10D8
277 Vac		V7-1E10D8
277 Vac	PCB	V7-1E17P02
277 Vac		V7-1E19E9
125 Vac		V7-1S17D8
277 Vac		V7-1V19E9
250 Vac		V7-1Z19E9
250 Vac		V7-2A17E9
250 Vac		V7-2B17D8
277 Vac	PCB	V7-2B17P02
125 Vac		V7-2S17D8
250 Vac		V7-3A17D8
277 Vac		V7-3E10E8
277 Vac		V7-3E10E9
277 Vac		V7-3E17D8
277 Vac		V7-3E17E9
125 Vac		V7-3E19E9
250 Vac		V7-3S17E9
250 Vac		V7-4A17D8
125 Vac		V7-4A18E9
125 Vac		V7-4S17D8
125 Vac		V7-5D17E9
277 Vac		V7-6B19D8
277 Vac		V7-6C17D8
277 Vac		V7-7A19D8

Straight lever

Type -002

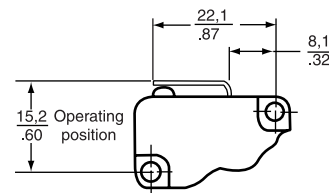

VOLTAGE	REFERENCE
277 Vac	V7-1C17D8-002
277 Vac	V7-1C17E9-002
277 Vac	V7-2B17E9-002
277 Vac	V7-6C18D8-002

**V7 Series
Miniature Basic Switches
(Continued)**

**Straight lever
Type -022**

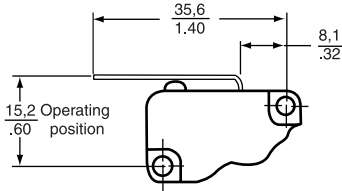

VOLTAGE	REFERENCE
250 Vac	V7-1A17D8-022
277 Vac	V7-1B19D8-022
277 Vac	V7-1C17D8-022
277 Vac	V7-1C18E9-022
125 Vac	V7-1S17D8-022
250 Vac	V7-2A17D8-022
277 Vac	V7-2B17D8-022
125 Vac	V7-2S17D8-022
277 Vac	V7-3E17E9-022
125 Vac	V7-3S17D8-022
125 Vac	V7-3S17E9-022

Type -048

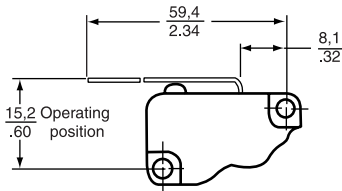

VOLTAGE	REFERENCE
277 Vac	V7-1B17D8-048
277 Vac	V7-1C17D8-048
277 Vac	V7-1V19E9-048
277 Vac	V7-2B17D8-048
277 Vac	V7-2B19E9-048
125 Vac	V7-3S17D8-048
277 Vac	V7-6C18D8-048
250 Vac	High temperature V7-9W1AE9-048

**Roller lever
Type -201**

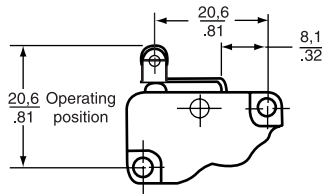

VOLTAGE	REFERENCE
277 Vac	V7-1C17D8-201
277 Vac	V7-1C17E9-201
125 Vac	V7-1S17D8-201
277 Vac	V7-2B17D8-201
125 Vac	V7-2S17D8-201
277 Vac	V7-7B17D8-201

Type -207

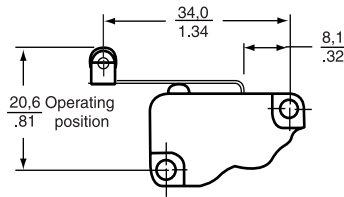

VOLTAGE	REFERENCE
277 Vac	V7-1B10E9-207
277 Vac	V7-1C17D8-207
277 Vac	V7-1C17E9-207
125 Vac	V7-1S17D8-207
277 Vac	V7-1V19E9-207
250 Vac	V7-2A17D8-207
277 Vac	V7-2B17D8-207
125 Vac	V7-7D17D8-207

**Simulated roller lever
Type -263**

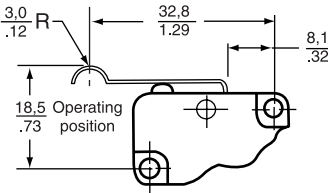

VOLTAGE	REFERENCE
277 Vac	V7-1B17D8-263
277 Vac	V7-1C17D8-263
125 Vac	V7-1S17D8-263
125 Vac	V7-2S17D8-263
125 Vac	V7-3S17E9-263
277 Vac	V7-6C17D8-263
277 Vac	V7-7B19D8-263

Index

111SM1	33	26PCCFA6D	4	BZ-2RW80-A2	32	CSNK591-001	28
111SM2-T	33	26PCCFA6G	4	BZ-2RW822	32	CSNP661	27
11SM1	33	26PCCFG6G	4	BZ-2RW8225551-A2	32	CSNP661-002	27
11SM601-H4	33	26PCDFA6D	4	BZ-2RW822-A2	32	CSNR151	27
11SX1-T	33	26PCDFA6G	4	BZ-2RW826-A2	32	CSNR151-002	27
141PC15G	9	26PCDFG2G	5	BZ-2RW82-A2	32	CSNR161	27
142PC01D	9	26PCFFA6G	4	BZ-2RW84-A2	32	CSNR161-002	27
142PC01G	9	26PCFFG6G	4	BZ-2RW863-A2	32	CSNT651	27
142PC02G	9	26PCFFU5G	5	BZ-R	31	CSNT651-001	27
142PC05D	9	26PCGFA6D	4	BZ-R169	31	DC001NDC4	6
142PC05D97	9	2SS52M	18	BZ-R-A2	31	DC005NDR4	6
142PC05G	9	2SS52M-S	18	CPCL04DFC	5	DCXL01DN	6
142PC15A	9	311SX2-T	33	CPCL04GFC	5	DCXL10DN	6
142PC15AW95	9	311SX5-T	33	CPCL10DF	5	DT-2R-A7	32
142PC15G	9	40PC001B1A	8	CPCL10DFC	5	DUXL01D	6
143PC03D	9	40PC006G1A	8	CPXL04DF	5	DUXL10D	6
143PC05DW	9	40PC015G1A	8	CSDA1BC	29	FSG15N1A	12
162PC01D	9	40PC015V1A	8	CSLA1CD	29	FSL05N2C	12
163PC01D36	9	40PC030G1A	8	CSLA1CF	29	HEL-700-T-0-A	14
163PC01D48	9	40PC100G1A	8	CSLA1CH	29	HEL-700-T-0-B	14
163PC01D61	9	40PC150G1A	8	CSLA1DE	28	HEL-700-T-1-A	14
163PC01D75	9	40PC250G1A	8	CSLA1DJ	28	HEL-700-T-1-B	14
164PC01D37	9	40PC500G1A	8	CSLA1DK	28	HEL-700-U-0-A	14
164PC01D76	9	6SX7-T	33	CSLA1EL	29	HEL-700-U-0-B	14
1SX1-T	33	AWM2100V	10	CSLA1GD	29	HEL-700-U-0-C	14
1TB1-2	32	AWM2200V	10	CSLA2CD	29	HEL-700-U-1-A	14
24PC01SMT	5	AWM2300V	10	CSLA2DE	28	HEL-700-U-1-B	14
24PC05SMT	5	AWM3100V	10	CSLA2DG	28	HEL-700-U-1-C	14
24PC15SMT	5	AWM3200V	10	CSLA2DJ	28	HEL-705-T-0-12-00	15
24PCAF6G	4	AWM3300V	10	CSLA2DK	28	HEL-705-T-1-12-00	15
24PCBFA6D	4	AWM42150VH	10	CSLA2EJ	29	HEL-705-U-0-12-00	15
24PCBFA6G	4	AWM42300V	10	CSLA2EL	29	HEL-705-U-1-12-00	15
24PCCFA6D	4	AWM43300V	10	CSLA2EM	29	HEL-707-T-0-12-00	15
24PCCFA6G	4	AWM43600V	10	CSLA2EN	29	HEL-707-T-1-12-00	15
24PCCFG6G	4	AWM5101VN	11	CSLA2GD	29	HEL-707-U-0-12-00	15
24PCDFA6D	4	AWM5102VN	11	CSLH3A45	29	HEL-707-U-1-12-00	15
24PCDFA6G	4	AWM5104VC	11	CSNA111	27	HEL-711-T-0-12-00	15
24PCDFG6G	4	AWM5104VN	11	CSNB121	27	HEL-711-T-1-12-00	15
24PCEFA6D	4	AWM720P1	11	CSNB131	27	HEL-711-U-0-12-00	15
24PCEFA6G	4	BA-2RB-A2	31	CSNC241-500	27	HEL-711-U-1-12-00	15
24PCFFA6D	4	BA-2RQ1-A2	31	CSNE151	26	HEL-712-T-0-12-00	15
24PCFFA6G	4	BA-2RV-A2	32	CSNE151-100	26	HEL-712-T-1-12-00	15
26PC01SMT	5	BE-2R-A4	31	CSNE151-200	26	HEL-712-U-0-12-00	15
26PC05SMT	5	BZ-2R-A2	31	CSNF151	27	HEL-712-U-1-12-00	15
26PC15SMT	5	BZ-2RD-A2	31	CSNF161	27	HEL-716-T-0-12-00	15
26PCAF6D	4	BZ-2RDS-A2	31	CSNF161-002	27	HEL-716-T-1-12-00	15
26PCAF6G	4	BZ-2RDS-A2S	31	CSNG251	27	HEL-716-U-0-12-00	15
26PCAFG6G	4	BZ-2RQ181-A2	32	CSNJ481	28	HEL-716-U-1-12-00	15
26PCBFA6D	4	BZ-2RQ18-A2	31	CSNJ481-001	28	HEL-716-U-1-12-C2	15
26PCBFA6G	4	BZ-2RQ1-A2	31	CSNK591	28	HEL-717-T-0-12-00	15

HEL-717-T-1-12-00 15	SE1450-003L 20	V5A010CB4E 34	V7-1Z19E9 35
HEL-717-U-0-12-00 15	SE1470-003L 20	V5B010CB3 34	V7-2A17D8-022 36
HEL-717-U-1-12-00 15	SE2460-003 20	V5B010FB3 34	V7-2A17D8-207 36
HIH-3602-A 13	SE2470-002 20	V5B010TB 34	V7-2A17E9 35
HIH-3602-C 13	SE3455-004 20	V5B210CB 34	V7-2B17D8 35
HIH-3602-L 13	SE3470-003 20	V5B210CB1C 34	V7-2B17D8-022 36
HIH-3610-001 13	SE5455-003 20	V5B210CB1E 34	V7-2B17D8-048 36
HIH-3610-002 13	SE5470-004 20	V5B210CB3D 34	V7-2B17D8-201 36
HIH-3610-003 13	SEP8505-003 20	V5C010BB 34	V7-2B17D8-207 36
HIH-3610-004 13	SEP8506-002 20	V5C010BB1G 34	V7-2B17E9 35
HLC1395-002 23	SEP8705-003 20	V5C010BB3B 34	V7-2B17E9-002 35
HLC2705-001 22	SEP8736-003 20	V5C010BB3D 34	V7-2B17P02 35
HOA0149-001 23	SMD2440-012 21	V5C010EB3 34	V7-2B19E9-048 36
HOA0866-T55 24	SME2470-021 20	V5C010TB3 34	V7-2S17D8 35
HOA0870-N51 24	SR13C-A1 18	V5D030BB 34	V7-2S17D8-022 36
HOA0880-P51 24	SR13D-A1 18	V5P010CB 34	V7-2S17D8-201 36
HOA0890-L55 24	SR13F-A1 18	V5R030CB 34	V7-2S17D8-263 36
HOA0901-011 22	SR13R-A1 18	V5S020CB 34	V7-3A17D8 35
HOA0902-011 22	SR16C-J4 18	V5S030CB 34	V7-3E10E8 35
HOA0961-N51 25	SR16C-J6 18	V7-1A17D8 35	V7-3E10E9 35
HOA0971-N51 25	SR16C-N 18	V7-1A17D8-022 36	V7-3E17D8 35
HOA1180-002 23	SR17C-J6 19	V7-1A17P02 35	V7-3E17E9 35
HOA1397-002 23	SR17C-J7 19	V7-1B10E9-207 36	V7-3E17E9-022 36
HOA1405-002 23	SS41 16	V7-1B17D8 35	V7-3E19E9 35
HOA1870-031 24	SS411A 16	V7-1B17D8-048 36	V7-3S17D8-022 36
HOA1877-001 24	SS413A 16	V7-1B17D8-263 36	V7-3S17D8-048 36
HOA1879-015 24	SS441A 16	V7-1B19D8-022 36	V7-3S17E9 35
HOA1882-012 24	SS443A 16	V7-1B19E9 35	V7-3S17E9-022 36
HOA2498-002 23	SS449A 16	V7-1C17D8 35	V7-3S17E9-263 36
HOA6963-N51 25	SS461A 16	V7-1C17D8-002 35	V7-4A17D8 35
HOA6972-N55 25	SS466A 16	V7-1C17D8-022 36	V7-4A18E9 35
HOA6981-L51 25	SS49 17	V7-1C17D8-048 36	V7-4S17D8 35
HOA6990-T51 25	SS495A 16	V7-1C17D8-201 36	V7-5D17E9 35
HOA7720-M22 25	SS495A1 16	V7-1C17D8-207 36	V7-6B19D8 35
HOA7730-M22 25	SS495A1-S 16	V7-1C17D8-263 36	V7-6C17D8 35
LL102101 30	SS495A-SP 16	V7-1C17E9 35	V7-6C17D8-263 36
LL103000 30	SS495B 17	V7-1C17E9-002 35	V7-6C18D8-002 35
LL103101 30	SS496B 17	V7-1C17E9-201 36	V7-6C18D8-048 36
LL105100 30	SS511AT 17	V7-1C17E9-207 36	V7-7A19D8 35
LLE102000 30	SS513AT 17	V7-1C18E9 35	V7-7B17D8-201 36
LLE105000 30	SS51T 17	V7-1C18E9-022 36	V7-7B19D8-263 36
SD1440-003L 21	SS541AT 17	V7-1D10D8 35	V7-7D17D8-207 36
SD2440-004 21	SS543AT 17	V7-1E10D8 35	V7-9W1AE9-048 36
SD3443-003 21	SS549AT 17	V7-1E17P02 35	XCA415AN 7
SD5443-003 21	SS561AT 17	V7-1E19E9 35	XCX01DNC 7
SD5600-001 22	SS566AT 17	V7-1S17D8 35	XCX01DNH 7
SD5610-001 22	SS94A1 17	V7-1S17D8-022 36	XCX15DNC 7
SD5620-001 22	SS94A1F 17	V7-1S17D8-201 36	XPC01DFC 7
SD5630-001 22	SS94A2 17	V7-1S17D8-207 36	XPC15DTC 7
SDP8405-003 21	SX3-T 33	V7-1S17D8-263 36	XSLX04GF 8
SDP8406-002 21	TD4A 15	V7-1V19E9 35	
SDP8436-003 21	TD5A 15	V7-1V19E9-048 36	
SDP8600-001 22	V5A010CB 34	V7-1V19E9-207 36	

**Inside back
cover - blank**

Warranty/Remedy

Honeywell warrants goods of its manufacture as being free of defective material and faulty workmanship. Contact your local sales office for warranty information. If warranted goods are returned to Honeywell during that period of coverage, Honeywell will repair or replace without charge those items it finds defective. The foregoing is Buyer's sole remedy and **is in lieu of all other warranties, expressed or implied, including those of merchantability and fitness for a particular purpose.**

While we provide application assistance, personally, through our literature and the Honeywell web site, it is up to the customer to determine the suitability of the product in the application.

Specifications may change at any time without notice. The information we supply is believed to be accurate and reliable as of this printing. However, we assume no responsibility for its use.

ASIA PACIFIC

Control Products

Asia Pacific Headquarters

Phone: +(65) 6355-2828
Fax: +(65) 6445-3033

Australia

Honeywell Limited
Phone: +(61) 2-9370-4500
FAX: +(61) 2-9370-4525
Toll Free 1300-36-39-36
Toll Free Fax: 1300-36-04-70

China - PRC - Beijing

Honeywell China Inc.
Phone: +(86-10) 8458-3280
Fax: +(86-10) 8458-3102

China - PRC - Shanghai

Honeywell China Inc.
Phone: +(86-21) 6237-0237
Fax: +(86-21) 6237-1237

China - Hong Kong S.A.R.

Honeywell Ltd.
Phone: +(852) 2953-6412
Fax: +(852) 2953-6767

Indonesia

Honeywell Indonesia Pte Ltd.
Phone: +(62) 21-535-8833
FAX: +(62) 21-5367 1008

India

TATA Honeywell Ltd.
Phone: +(91) 20 6870 445/
446
Fax: +(91) 20 681 2243/ 687
5992

Japan

Honeywell Inc
Phone: +(81) 3 5440 1425
Fax: +(81) 3 5440 1368

South Korea

Honeywell Korea Co Ltd
Phone: +(822) 799-6167
Fax: +(822) 792-9013

Malaysia

Honeywell Engineering Sdn
Bhd
Phone: +(60-3) 7958-4988
Fax: +(60-3) 7958-8922

New Zealand

Honeywell Limited
Phone: +(64-9) 623-5050
Fax: +(64-9) 623-5060
Toll Free (0800) 202-088

Philippines

Honeywell Systems
(Philippines) Inc.
Phone: +(63-2) 636-1661 /
1662
Fax: +(63-2) 638-4013

Singapore

Honeywell South East Asia
Phone: +(65) 6355-2828
Fax: +(65) 6445-3033

Thailand

Honeywell Systems (Thailand)
Ltd.
Phone: +(662) 693-3099
FAX: +(662) 693-3085

Taiwan R.O.C.

Honeywell Taiwan Ltd.
Phone: +(886-2) 2245-1000
FAX: +(886-2) 2245-3242

EUROPE

Austria

Honeywell Austria GmbH
Phone: +(43) 1 727 80 366/
246
Fax: +(43) 1 727 80 337

Belgium

Honeywell SA/NV
Phone: +(32) 2 728 2522
FAX: +(32) 2 728 2502

Bulgaria

Honeywell EOOD
Phone: +(359) 2 79 40 27
FAX: +(359) 2 79 40 90

Czech Republic

Honeywell spol. s.r.o.
Phone: +(420) 2 6112 3469/
3424
FAX: +(420) 2 6112 3461

Denmark

Honeywell A/S
Phone: +(45) 39 55 55 55
FAX: +(45) 39 55 55 58

Finland

Honeywell OY
Phone: +(358) 9 3480101
FAX: +(358) 9 34801375

France

Honeywell SA
Phone: +(33) 1 60 19 80 40
FAX: +(33) 1 60 19 81 73

Germany

Honeywell AG
Phone: +(49) 69 8064 444
FAX: +(49) 69 8064 442

Hungary

Honeywell Kft.
Phone: +(36 1) 451 4300
FAX: +(36 1) 451 4343

Italy

Honeywell S.p.A.
Phone: +(39) 02 92146 450/
456
FAX: +(39) 02 92146 490

The Netherlands

Honeywell B.V.
Phone: +(31) 20 565 69 11
FAX: +(31) 20 565 66 00

Sales and Service

Honeywell serves its customers through a worldwide network of sales offices and distributors. For application assistance, current specifications, pricing or name of the nearest Authorised Distributor, contact your local sales office or: INTERNET: www.honeywell.com/sensing

E-mail: info.sc@honeywell.com

Norway

Honeywell A/S
Phone: +(47) 66 76 20 00
FAX: +(47) 66 76 20 90

Poland

Honeywell Sp. z o.o
Phone: +(48) 22 606 0900
FAX: +(48) 22 606 0901

Portugal

Honeywell Portugal Lda
Phone: +(351 21) 424 50 00
FAX: +(351 21) 424 50 99

Romania

Honeywell Bucharest
Phone: +(40) 1 2110076
FAX: +(40) 1 2103375

Commonwealth of Independent States (CIS)

Z.A.O. Honeywell
Phone: +(7 095) 796 98 36
FAX: +(7 095) 796 98 93

Slovak Republic

Honeywell s.r.o.
Phone: +(421 7) 58247 403/
400
FAX: +(421 7) 58247 415

South Africa (Republic of)

Honeywell Southern Africa
Honeywell S.A. Pty. Ltd
Phone: +(27) 11 805 1201
FAX: +(27) 11 805 1504

Spain

Honeywell S.A.
Phone: +(34) 91 313 6100
FAX: +(34) 91 313 6129

Sweden

Honeywell AB
Phone: +(46) 8 775 55 00
FAX: +(46) 8 775 56 00

Switzerland

Honeywell AG
Phone: +(41) 1 855 24 40
FAX: +(41) 1 855 24 45

Turkey

Honeywell Turkey A.S.
Phone: +(90) 216 5756620
FAX: +(90) 216 5756637

United Kingdom

Honeywell Control Systems Ltd
Phone: +(44) 1698 481481
FAX: +(44) 1698 481276

Mediterranean & African Distributors

Honeywell SpA
Phone: +(39) 2 921 46 232
FAX: +(39) 2 921 46 233

Middle East Headquarters

Honeywell Middle East Ltd.
Phone: +(9712) 443 2119
FAX: +(9712) 443 2536

NORTH AMERICA

Canada

Honeywell LTD
Phone: 1-800-737-3360
FAX: 1-800-565-4130

USA

Honeywell
Control Products,
International Headquarters
Phone: 1-800-537-6945
1-815-235-6847
FAX: 1-815-235-6545
E-mail:
info.sc@honeywell.com

LATIN AMERICA

Argentina

Honeywell S.A.I.C.
Phone: +(54-11) 4383-3637
FAX: +(54-11) 4325-6470

Brazil

Honeywell do Brasil & Cia
Phone: +(55-11) 7266-1900
FAX: +(55-11) 7266-1905

Chile

Honeywell Chile, S.A.
Phone: +(56-2) 233-0688
FAX: +(56-2) 231-6679

Columbia

Honeywell Columbia, S.A.
Phone: +(57-1) 623-3239/
3051
FAX: +(57-1) 623-3395

Ecuador

Honeywell S.A.
Phone: +(593-2) 981-560/1
FAX: +(593-2) 981-562

Mexico

Honeywell S.A. de C.V.
Phone: +(52) 55 5259-1966
FAX: +(52) 55 5570-2985

Puerto Rico

Honeywell Inc.
Phone: +(809) 792-7075
FAX: +(809) 792-0053

Venezuela

Honeywell CA
Phone: +(58-2) 238-0211
FAX: +(58-2) 238-3391

This publication does not constitute a contract between Honeywell and its customers. The contents may be changed at any time without notice. It is the customer's responsibility to ensure safe installation and operation of the products. Detailed mounting drawings of all products illustrated are available on request. © Honeywell 2002. All rights reserved.

Honeywell

Honeywell Automation & Control Products

Newhouse Industrial Estate

Motherwell ML1 5SB

Scotland, UK

www.honeywell.com/sensing