

MC9S12DP512

Device Guide

V01.25

Covers also

**MC9S12DT512, MC9S12DJ512,
MC9S12A512**

**Original Release Date: 27 Nov 2001
Revised: 05 Jul 2005**

Freescale Semiconductor, Inc.

Revision History

Version Number	Revision Date	Effective Date	Author	Description of Changes
V01.00	27 Nov 2001	11 Feb 2002		- Initial version based on DP256 V2.09.
V01.01	13 Mar 2002	13 Mar 2002		<ul style="list-style-type: none"> - Updated document formats. - Removed reference to SIM in overview. - Changed XCLKS to PE7 in signal description. - Removed "Oscillator start-up time from POR or STOP" from Oscillator Characteristics. - Changed VDD and VDDPLL to 2.35V. - Updated C_{INS}. - Updated I_{OL}/I_{OH} values. - Updated input capacitance. - Updated NVM timing characteristics.
V01.02	02 Apr 2002	02 Apr 2002		- Updated document reference (SPI, SCI).
V01.03	15 Apr 2002	15 Apr 2002		<ul style="list-style-type: none"> - Corrected values in device memory map (RAM start, flash protected sector sizes). - Updated document reference (SCI).
V01.04	06 Jun 2002	06 Jun 2002		- Changed all operating frequency references to 50MHz XTAL and removed references to 80 pin LQFP.
V01.05	05 Jul 2002	05 Jul 2002		<ul style="list-style-type: none"> - Preface Table "Document References": Changed to full naming for each block. - Table "Interrupt Vector Locations", Column "Local Enable": Corrected several register and bit names. - Table "Signal Properties": Added column "Internal Pull Resistor". - Table "PLL Characteristics": Updated parameters K1 and f1 - Figure "Basic PLL functional diagram": Inserted XFC pin in diagram - Enhanced section "XFC Component Selection" - Added to Sections ATD, ECT and PWM: freeze mode = active BDM mode.

Freescale reserves the right to make changes without further notice to any products herein to improve reliability, function or design. Freescale does not assume any liability arising out of the application or use of any product or circuit described herein; neither does it convey any license under its patent rights nor the rights of others. Freescale products are not designed, intended, or authorized for use as components in systems intended for surgical implant into the body, or other applications intended to support or sustain life, or for any other application in which the failure of the Freescale product could create a situation where personal injury or death may occur. Should Buyer purchase or use Freescale products for any such unintended or unauthorized application, Buyer shall indemnify and hold Freescale and its officers, employees, subsidiaries, affiliates, and distributors harmless against all claims, costs, damages, and expenses, and reasonable attorney fees arising out of, directly or indirectly, any claim of personal injury or death associated with such unintended or unauthorized use, even if such claim alleges that Freescale was negligent regarding the design or manufacture of the part.

Version Number	Revision Date	Effective Date	Author	Description of Changes
V01.06	24 Jul 2002	24 Jul 2002		<ul style="list-style-type: none"> - Updated SPI electrical characteristics. - Updated Derivative Differences table. - Added ordering number example. - Added Detailed Register Map. - Changed Internal Pull Resistor column of signal table. - Added pull device description for MODC pin. - Corrected XCLKS figure titles. Moved table to section Modes of Operation. - Removed '1/2' from BDM in Figure Clock Connections. - Completely reworked section Modes of Operation. Added Chip Configuration Summary and Low Power Mode description. - Changed classification to C for internal pull currents in Table 5V I/O Characteristics. - Changed input leakage to 1uA for all pins. - Updated VREG section and layout recommendation. - Moved Power and Ground Connection Summary table to start of Power Supply Pins section. - Added ROMONE to pinout
V01.07	29 Jul 2002	05 Aug 2002		<ul style="list-style-type: none"> - Corrected mem map: 'MEBI map x of 3' - Corrected mem map: KEYEN bits in FSEC. - Added section Printed Circuit Board Layout Proposal. - Corrected addresses in Reserved, CAN and EEP buffer map. - Updated NVM electricals.
V01.08	21 Aug 2002	21 Aug 2002		<ul style="list-style-type: none"> - Updated table 'Document References' - Added section 'Oscillator (OSC) Block Description'
V01.09	24 Sep 2002	24 Sep 2002		<ul style="list-style-type: none"> - Section HCS12 Core Block Description: mentioned alternate clock of BDM to be equivalent to oscillator clock - Corrected tables 0-1 and 0-2
V01.10	18 Oct 2002	18 Oct 2002		<ul style="list-style-type: none"> - Added derivatives to cover sheet. - Added part ID for 1L00M maskset. - Corrected in footnote of Table "PLL Characteristics": $f_{OSC} = 4\text{MHz}$.
V01.11	29 Oct 2002	29 Oct 2002		<ul style="list-style-type: none"> - Renamed Preface section to Derivative Differences and Document references. - Added A512 derivative. - Updated module set of DJ512 in Table 0-1. - Added details for derivatives without CAN and/or BDLC modules.
V01.12	03 Dec 2002	03 Dec 2002		<ul style="list-style-type: none"> - Corrected several entries in 'Detailed Memory Map'. - Removed footnote on input leakage current from table '5V I/O Characteristics'.
V01.13	08 Jan 2003	08 Jan 2003		<ul style="list-style-type: none"> - Updated section 'Unsecuring the Microcontroller'. - Updated footnote 1 in table 'Operating Conditions'.
V01.14	23 Jan 2003	23 Jan 2003		<ul style="list-style-type: none"> - Renamed ROMONE pin to ROMCTL.
V01.15	28 Feb 2003	28 Feb 2003		<ul style="list-style-type: none"> - Corrected PE[1,0] pull specification in Signal Properties Summary Table.

MC9S12DP512 Device Guide V01.25

Version Number	Revision Date	Effective Date	Author	Description of Changes
V01.16	31 Mar 2003	31 Mar 2003		<ul style="list-style-type: none"> - Corrections in App. A 'NVM, Flash and EEPROM': - Number of words per flash row = 64 - Replaced 'burst programming' with 'row programming' - Sector erase size = 1024 bytes - Corrected feature description ECT - Corrected min. bus freq. in table 'Operating Conditions'
V01.17	30 May 2003	30 May 2003		<ul style="list-style-type: none"> - Replaced references to HCS12 Core Guide with the individual HCS12 Block guides throughout document - Table 'Absolute Maximum Ratings' corrected footnote on clamp of TEST pin
V01.18	23 Jul 2003	23 Jul 2003		<ul style="list-style-type: none"> - Mentioned 'S12 LRAE' bootloader in Flash section - Document References: corrected S12 CPU document reference
V01.19	24 Jul 2003	24 Jul 2003		<ul style="list-style-type: none"> - Added part ID for 2L00M maskset.
V01.20	01 Sep 2003	01 Sep 2003		<ul style="list-style-type: none"> - Added part ID for 3L00M maskset. - Added cycle definition to 'CPU 12 Block Description'. - Diagram 'Clock Connections': Connected Bus Clock to HCS12 Core. - Corrected 'Background Debug Module' to 'HCS12 Breakpoint' at address \$0028 - \$002F in table 1-1. - Corrected 'Blank Check Time Flash' value in table 'NVM Timing Characteristics' - Added EXTAL pin VIH, VIL and EXTAL pin hysteresis value to 'Oscillator Characteristics'. Updated oscillator description and table note.
V01.21	08 Mar 2004	08 Mar 2004		<ul style="list-style-type: none"> - Added part ID for 4L00M maskset. - Corrected pin name KWP5 in device pinout.
V01.22	23 Aug 2004	23 Aug 2004		<ul style="list-style-type: none"> - Updated $V_{IH,EXTAL}$ and $V_{IL,EXTAL}$ in table 'Oscillator Characteristics' - Removed item 'Oscillator' from table 'Operating Conditions' as already covered in table 'Oscillator Characteristics'
V01.23	09 Feb 2005	09 Feb 2005		<ul style="list-style-type: none"> - Corrected Flash Row Programming Time in NVM Timing Characteristics
V01.24	01 Apr 2005	01 Apr 2005		<ul style="list-style-type: none"> - Changed T_{Javg} and added footnote to data retention time in NVM Reliability Characteristics
V01.25	05 Jul 2005	05 Jul 2005		<ul style="list-style-type: none"> - Updated NVM Reliability Characteristics

Table of Contents

Section 1 Introduction

1.1	Overview	19
1.2	Features	19
1.3	Modes of Operation	21
1.4	Block Diagram	22
1.5	Device Memory Map	24
1.5.1	Detailed Register Map	27
1.6	Part ID Assignments	49
1.7	Memory Size Assignments	49

Section 2 Signal Description

2.1	Device Pinout	52
2.2	Signal Properties Summary	53
2.3	Detailed Signal Descriptions	55
2.3.1	EXTAL, XTAL — Oscillator Pins	55
2.3.2	RESET — External Reset Pin	55
2.3.3	TEST — Test Pin	55
2.3.4	VREGEN — Voltage Regulator Enable Pin	55
2.3.5	XFC — PLL Loop Filter Pin	56
2.3.6	BKGD / TAGHI / MODC — Background Debug, Tag High, and Mode Pin	56
2.3.7	PAD15 / AN15 / ETRIG1 — Port AD Input Pin of ATD1	56
2.3.8	PAD[14:08] / AN[14:08] — Port AD Input Pins of ATD1	56
2.3.9	PAD7 / AN07 / ETRIG0 — Port AD Input Pin of ATD0	56
2.3.10	PAD[06:00] / AN[06:00] — Port AD Input Pins of ATD0	56
2.3.11	PA[7:0] / ADDR[15:8] / DATA[15:8] — Port A I/O Pins	57
2.3.12	PB[7:0] / ADDR[7:0] / DATA[7:0] — Port B I/O Pins	57
2.3.13	PE7 / NOACC / XCLKS — Port E I/O Pin 7	57
2.3.14	PE6 / MODB / IPIPE1 — Port E I/O Pin 6	58
2.3.15	PE5 / MODA / IPIPE0 — Port E I/O Pin 5	58
2.3.16	PE4 / ECLK — Port E I/O Pin 4	58
2.3.17	PE3 / LSTRB / TAGLO — Port E I/O Pin 3	59
2.3.18	PE2 / R/W — Port E I/O Pin 2	59
2.3.19	PE1 / IRQ — Port E Input Pin 1	59

2.3.20	PE0 / XIRQ — Port E Input Pin 0	59
2.3.21	PH7 / KWH7 / SS2 — Port H I/O Pin 7	59
2.3.22	PH6 / KWH6 / SCK2 — Port H I/O Pin 6	59
2.3.23	PH5 / KWH5 / MOSI2 — Port H I/O Pin 5	59
2.3.24	PH4 / KWH4 / MISO2 — Port H I/O Pin 2	59
2.3.25	PH3 / KWH3 / SS1 — Port H I/O Pin 3	60
2.3.26	PH2 / KWH2 / SCK1 — Port H I/O Pin 2	60
2.3.27	PH1 / KWH1 / MOSI1 — Port H I/O Pin 1	60
2.3.28	PH0 / KWH0 / MISO1 — Port H I/O Pin 0	60
2.3.29	PJ7 / KWJ7 / TXCAN4 / SCL / TXCAN0 — PORT J I/O Pin 7	60
2.3.30	PJ6 / KWJ6 / RXCAN4 / SDA / RXCAN0 — PORT J I/O Pin 6	60
2.3.31	PJ[1:0] / KWJ[1:0] — Port J I/O Pins [1:0]	60
2.3.32	PK7 / ECS / ROMCTL — Port K I/O Pin 7	60
2.3.33	PK[5:0] / XADDR[19:14] — Port K I/O Pins [5:0]	61
2.3.34	PM7 / TXCAN3 / TXCAN4 — Port M I/O Pin 7	61
2.3.35	PM6 / RXCAN3 / RXCAN4 — Port M I/O Pin 6	61
2.3.36	PM5 / TXCAN2 / TXCAN0 / TXCAN4 / SCK0 — Port M I/O Pin 5	61
2.3.37	PM4 / RXCAN2 / RXCAN0 / RXCAN4/ MOSI0 — Port M I/O Pin 4	61
2.3.38	PM3 / TXCAN1 / TXCAN0 / SS0 — Port M I/O Pin 3	61
2.3.39	PM2 / RXCAN1 / RXCAN0 / MISO0 — Port M I/O Pin 2	61
2.3.40	PM1 / TXCAN0 / TXB — Port M I/O Pin 1	62
2.3.41	PM0 / RXCAN0 / RXB — Port M I/O Pin 0	62
2.3.42	PP7 / KWP7 / PWM7 / SCK2 — Port P I/O Pin 7	62
2.3.43	PP6 / KWP6 / PWM6 / SS2 — Port P I/O Pin 6	62
2.3.44	PP5 / KWP5 / PWM5 / MOSI2 — Port P I/O Pin 5	62
2.3.45	PP4 / KWP4 / PWM4 / MISO2 — Port P I/O Pin 4	62
2.3.46	PP3 / KWP3 / PWM3 / SS1 — Port P I/O Pin 3	62
2.3.47	PP2 / KWP2 / PWM2 / SCK1 — Port P I/O Pin 2	63
2.3.48	PP1 / KWP1 / PWM1 / MOSI1 — Port P I/O Pin 1	63
2.3.49	PP0 / KWP0 / PWM0 / MISO1 — Port P I/O Pin 0	63
2.3.50	PS7 / SS0 — Port S I/O Pin 7	63
2.3.51	PS6 / SCK0 — Port S I/O Pin 6	63
2.3.52	PS5 / MOSI0 — Port S I/O Pin 5	63
2.3.53	PS4 / MISO0 — Port S I/O Pin 4	63
2.3.54	PS3 / TXD1 — Port S I/O Pin 3	63
2.3.55	PS2 / RXD1 — Port S I/O Pin 2	64

2.3.56	PS1 / TXD0 — Port S I/O Pin 1	64
2.3.57	PS0 / RXD0 — Port S I/O Pin 0	64
2.3.58	PT[7:0] / IOC[7:0] — Port T I/O Pins [7:0]	64
2.4	Power Supply Pins	64
2.4.1	VDDX, VSSX — Power & Ground Pins for I/O Drivers	65
2.4.2	VDDR, VSSR — Power & Ground Pins for I/O Drivers & Internal Voltage Regulator	65
2.4.3	VDD1, VDD2, VSS1, VSS2 — Internal Logic Power Supply Pins	65
2.4.4	VDDA, VSSA — Power Supply Pins for ATD and VREG	65
2.4.5	VRH, VRL — ATD Reference Voltage Input Pins	65
2.4.6	VDDPLL, VSSPLL — Power Supply Pins for PLL	65
2.4.7	VREGEN — On Chip Voltage Regulator Enable	66

Section 3 System Clock Description

3.1	Overview.	67
-----	-------------------	----

Section 4 Modes of Operation

4.1	Overview.	69
4.2	Chip Configuration Summary	69
4.3	Security.	70
4.3.1	Securing the Microcontroller	70
4.3.2	Operation of the Secured Microcontroller	70
4.3.3	Unsecuring the Microcontroller	71
4.4	Low Power Modes	71
4.4.1	Stop	71
4.4.2	Pseudo Stop.	71
4.4.3	Wait	71
4.4.4	Run.	72

Section 5 Resets and Interrupts

5.1	Overview.	73
5.2	Vectors	73
5.2.1	Vector Table.	73
5.3	Effects of Reset	74
5.3.1	I/O pins.	74
5.3.2	Memory	75

Section 6 HCS12 Core Block Description

6.1	CPU12 Block Description	77
6.1.1	Device-specific information	77
6.2	HCS12 Module Mapping Control (MMC) Block Description	77
6.2.1	Device-specific information	77
6.3	HCS12 Multiplexed External Bus Interface (MEBI) Block Description	77
6.3.1	Device-specific information	77
6.4	HCS12 Interrupt (INT) Block Description	77
6.5	HCS12 Background Debug (BDM) Block Description	78
6.5.1	Device-specific information	78
6.6	HCS12 Breakpoint (BKP) Block Description	78

Section 7 Clock and Reset Generator (CRG) Block Description

7.1	Device-specific information.	78
-----	--------------------------------------	----

Section 8 Oscillator (OSC) Block Description

8.1	Device-specific information.	78
-----	--------------------------------------	----

Section 9 Enhanced Capture Timer (ECT) Block Description

Section 10 Analog to Digital Converter (ATD) Block Description

Section 11 Inter-IC Bus (IIC) Block Description

Section 12 Serial Communications Interface (SCI) Block Description

Section 13 Serial Peripheral Interface (SPI) Block Description

Section 14 J1850 (BDLC) Block Description

Section 15 Pulse Width Modulator (PWM) Block Description

Section 16 Flash EEPROM 512K Block Description

Section 17 EEPROM 4K Block Description

Section 18 RAM Block Description

Section 19 MSCAN Block Description



Section 20 Port Integration Module (PIM) Block Description

Section 21 Voltage Regulator (VREG) Block Description

Section 22 Printed Circuit Board Layout Proposal

Appendix A Electrical Characteristics

A.1	General	85
A.1.1	Parameter Classification	85
A.1.2	Power Supply	85
A.1.3	Pins	86
A.1.4	Current Injection	87
A.1.5	Absolute Maximum Ratings	87
A.1.6	ESD Protection and Latch-up Immunity	88
A.1.7	Operating Conditions	89
A.1.8	Power Dissipation and Thermal Characteristics	89
A.1.9	I/O Characteristics	91
A.1.10	Supply Currents	92
A.2	ATD Characteristics	95
A.2.1	ATD Operating Characteristics	95
A.2.2	Factors influencing accuracy	95
A.2.3	ATD accuracy	97
A.3	NVM, Flash and EEPROM	99
A.3.1	NVM timing	99
A.3.2	NVM Reliability	101
A.4	Voltage Regulator	103
A.5	Reset, Oscillator and PLL	105
A.5.1	Startup	105
A.5.2	Oscillator	106
A.5.3	Phase Locked Loop	107
A.6	MSCAN	111
A.7	SPI	113
A.7.1	Master Mode	113
A.7.2	Slave Mode	115
A.8	External Bus Timing	117
A.8.1	General Muxed Bus Timing	117

Appendix B Package Information

B.1	General.....	121
B.2	112-pin LQFP package.....	122

List of Figures

Figure 0-1	Order Part Number Example	15
Figure 1-1	MC9S12DP512 Block Diagram	23
Figure 1-2	MC9S12DP512 Memory Map	26
Figure 2-1	Pin Assignments in 112-pin LQFP	52
Figure 2-2	PLL Loop Filter Connections	56
Figure 2-3	Colpitts Oscillator Connections (PE7=1)	57
Figure 2-4	Pierce Oscillator Connections (PE7=0)	58
Figure 2-5	External Clock Connections (PE7=0)	58
Figure 3-1	Clock Connections.	67
Figure 22-1	Recommended PCB Layout for 112LQFP Colpitts Oscillator	82
Figure 22-2	Recommended PCB Layout for 112LQFP Pierce Oscillator	83
Figure A-1	ATD Accuracy Definitions	98
Figure A-2	Typical Endurance vs Temperature.	102
Figure A-3	Basic PLL functional diagram	107
Figure A-4	Jitter Definitions	109
Figure A-5	Maximum bus clock jitter approximation	109
Figure A-6	SPI Master Timing (CPHA=0)	113
Figure A-7	SPI Master Timing (CPHA=1)	114
Figure A-8	SPI Slave Timing (CPHA=0)	115
Figure A-9	SPI Slave Timing (CPHA=1)	116
Figure A-10	General External Bus Timing.	118
Figure B-1	112-pin LQFP mechanical dimensions (case no. 987)	122



List of Tables

Table 0-1	Derivative Differences	15
Table 0-2	Document References	17
Table 1-1	Device Memory Map	24
\$0000 - \$000F	MEBI map 1 of 3 (HCS12 Multiplexed External Bus Interface)	27
\$0010 - \$0014	MMC map 1 of 4 (HCS12 Module Mapping Control)	27
\$0015 - \$0016	INT map 1 of 2 (HCS12 Interrupt)	28
\$0017 - \$0019	Reserved	28
\$001A - \$001B	Device ID Register (Table 1-3)	28
\$001C - \$001D	MMC map 3 of 4 (HCS12 Module Mapping Control, Table 1-4)	28
\$001E - \$001E	MEBI map 2 of 3 (HCS12 Multiplexed External Bus Interface)	28
\$001F - \$001F	INT map 2 of 2 (HCS12 Interrupt)	28
\$0020 - \$0027	Reserved	28
\$0028 - \$002F	BKP (HCS12 Breakpoint)	29
\$0030 - \$0031	MMC map 4 of 4 (HCS12 Module Mapping Control)	29
\$0032 - \$0033	MEBI map 3 of 3 (HCS12 Multiplexed External Bus Interface)	29
\$0034 - \$003F	CRG (Clock and Reset Generator)	29
\$0040 - \$007F	ECT (Enhanced Capture Timer 16 Bit 8 Channels)	30
\$0080 - \$009F	ATD0 (Analog to Digital Converter 10 Bit 8 Channel)	33
\$00A0 - \$00C7	PWM (Pulse Width Modulator 8 Bit 8 Channel)	34
\$00C8 - \$00CF	SCI0 (Asynchronous Serial Interface)	36
\$00D0 - \$00D7	SCI1 (Asynchronous Serial Interface)	36
\$00D8 - \$00DF	SPI0 (Serial Peripheral Interface)	36
\$00E0 - \$00E7	IIC (Inter IC Bus)	37
\$00E8 - \$00EF	BDLC (Bytelevel Data Link Controller J1850)	37
\$00F0 - \$00F7	SPI1 (Serial Peripheral Interface)	38
\$00F8 - \$00FF	SPI2 (Serial Peripheral Interface)	38
\$0100 - \$010F	Flash Control Register (fts512k4)	38
\$0110 - \$011B	EEPROM Control Register (eets4k)	39
\$011C - \$011F	Reserved for RAM Control Register	39
\$0120 - \$013F	ATD1 (Analog to Digital Converter 10 Bit 8 Channel)	40
\$0140 - \$017F	CAN0 (Freescale Scalable CAN - FSCAN)	41
Table 1-2	Detailed MSCAN Foreground Receive and Transmit Buffer Layout	42
\$0180 - \$01BF	CAN1 (Freescale Scalable CAN - FSCAN)	43

\$01C0 - \$01FF	CAN2 (Freescale Scalable CAN - FSCAN)	44
\$0200 - \$023F	CAN3 (Freescale Scalable CAN - FSCAN)	45
\$0240 - \$027F	PIM (Port Integration Module PIM_9DP256)	46
\$0280 - \$02BF	CAN4 (Freescale Scalable CAN - FSCAN)	48
\$02C0 - \$03FF	Reserved	49
Table 1-3	Assigned Part ID Numbers	49
Table 1-4	Memory size registers	49
Table 2-1	Signal Properties	53
Table 2-2	MC9S12DP512 Power and Ground Connection Summary	64
Table 4-1	Mode Selection	69
Table 4-2	Clock Selection Based on PE7	70
Table 4-3	Voltage Regulator VREGEN	70
Table 5-1	Interrupt Vector Locations	73
Table 22-1	Suggested External Component Values	81
Table A-1	Absolute Maximum Ratings	87
Table A-2	ESD and Latch-up Test Conditions	88
Table A-3	ESD and Latch-up Protection Characteristics	88
Table A-4	Operating Conditions	89
Table A-5	Thermal Package Characteristics	91
Table A-6	5V I/O Characteristics	92
Table A-7	Supply Current Characteristics	93
Table A-8	ATD Operating Characteristics	95
Table A-9	ATD Electrical Characteristics	96
Table A-10	ATD Conversion Performance	97
Table A-11	NVM Timing Characteristics	100
Table A-12	NVM Reliability Characteristics	101
Table A-13	Voltage Regulator Recommended Load Capacitances	103
Table A-14	Startup Characteristics	105
Table A-15	Oscillator Characteristics	106
Table A-16	PLL Characteristics	110
Table A-17	MSCAN Wake-up Pulse Characteristics	111
Table A-18	Measurement Conditions	113
Table A-19	SPI Master Mode Timing Characteristics	114
Table A-20	SPI Slave Mode Timing Characteristics	116
Table A-21	Expanded Bus Timing Characteristics	119

Derivative Differences and Document References

Derivative Differences

Table 0-1 shows the availability of peripheral modules on the various derivatives. For details about the compatibility within the MC9S12D-Family refer also to engineering bulletin EB386.

Table 0-1 Derivative Differences¹

Modules	MC9S12DP512	MC9S12DT512	MC9S12DJ512	MC9S12A512
# of CANs	5	3	2	0
CAN0	✓	✓	✓	—
CAN1	✓	✓	—	—
CAN2	✓	—	—	—
CAN3	✓	—	—	—
CAN4	✓	✓	✓	—
J1850/BDLC	✓	—	✓	—
Package	112 LQFP	112 LQFP	112 LQFP	112 LQFP
Package Code	PV	PV	PV	PV
Mask set	L00M	L00M	L00M	L00M
Temp Options	M, V, C	M, V, C	M, V, C	C
Notes	An errata exists contact Sales Office	An errata exists contact Sales Office	An errata exists contact Sales Office	An errata exists contact Sales Office

NOTES:

1. ✓: Available for this device, —: Not available for this device

The following figure provides an ordering number example for the MC9S12D-Family devices.

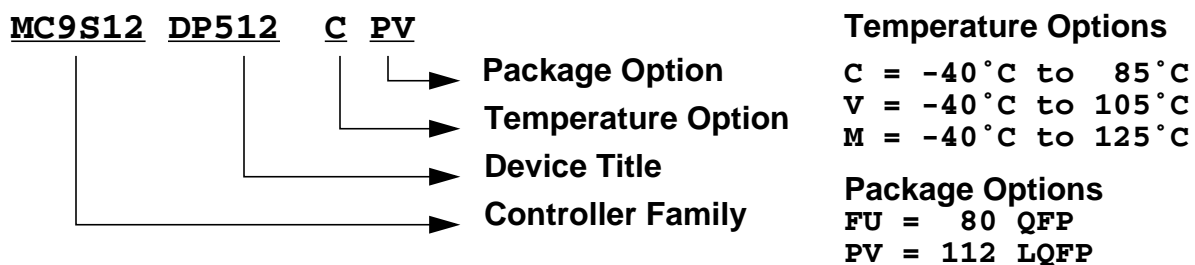

Figure 0-1 Order Part Number Example

The following items should be considered when using a derivative (**Table 0-1**):

- **Registers**

- Do not write or read CAN0 registers (after reset: address range \$0140 - \$017F), if using a derivative without CAN0.
- Do not write or read CAN1 registers (after reset: address range \$0180 - \$01BF), if using a derivative without CAN1.
- Do not write or read CAN2 registers (after reset: address range \$01C0 - \$01FF), if using a derivative without CAN2.
- Do not write or read CAN3 registers (after reset: address range \$0200 - \$023F), if using a derivative without CAN3.
- Do not write or read CAN4 registers (after reset: address range \$0280 - \$02BF), if using a derivative without CAN4.
- Do not write or read BDLC registers (after reset: address range \$00E8 - \$00EF), if using a derivative without BDLC.

- **Interrupts**

- Fill the four CAN0 interrupt vectors (\$FFB0 - \$FFB7) according to your coding policies for unused interrupts, if using a derivative without CAN0.
- Fill the four CAN1 interrupt vectors (\$FFA8 - \$FFAF) according to your coding policies for unused interrupts, if using a derivative without CAN1.
- Fill the four CAN2 interrupt vectors (\$FFA0 - \$FFA7) according to your coding policies for unused interrupts, if using a derivative without CAN2.
- Fill the four CAN3 interrupt vectors (\$FF98 - \$FF9F) according to your coding policies for unused interrupts, if using a derivative without CAN3.
- Fill the four CAN4 interrupt vectors (\$FF90 - \$FF97) according to your coding policies for unused interrupts, if using a derivative without CAN4.
- Fill the BDLC interrupt vector (\$FFC2, \$FFC3) according to your coding policies for unused interrupts, if using a derivative without BDLC.

- **Ports**

- The CAN0 pin functionality (TXCAN0, RXCAN0) is not available on port PJ7, PJ6, PM5, PM4, PM3, PM2, PM1 and PM0, if using a derivative without CAN0.
 - The CAN1 pin functionality (TXCAN1, RXCAN1) is not available on port PM3 and PM2, if using a derivative without CAN1.
 - The CAN2 pin functionality (TXCAN2, RXCAN2) is not available on port PM5 and PM4, if using a derivative without CAN2.
 - The CAN3 pin functionality (TXCAN3, RXCAN3) is not available on port PM7 and PM6, if using a derivative without CAN3.
-

- The CAN4 pin functionality (TXCAN4, RXCAN4) is not available on port PJ7, PJ6, PM7, PM6, PM5 and PM4, if using a derivative without CAN0.
- The BDLC pin functionality (TXB, RXB) is not available on port PM1 and PM0, if using a derivative without BDLC.
- Do not write MODRR1 and MODRR0 bits of Module Routing Register (PIM_9DP256 Block Guide), if using a derivative without CAN0.
- Do not write MODRR3 and MODRR2 bits of Module Routing Register (PIM_9DP256 Block Guide), if using a derivative without CAN4.

Document References

The Device Guide provides information about the MC9S12DP512 device made up of standard HCS12 blocks and the HCS12 processor core.

This document is part of the customer documentation. A complete set of device manuals also includes the individual Block Guides of the implemented modules. In an effort to reduce redundancy, all module specific information is located only in the respective Block Guide. If applicable, special implementation details of the module are given in the block description sections of this document.

See **Table 0-2** for names and versions of the referenced documents throughout the Device Guide.

Table 0-2 Document References

Block Guide	Version	Document Order Number
HCS12 CPU Reference Manual	V02	S12CPUV2/D
HCS12 Module Mapping Control (MMC) Block Guide	V04	S12MMCV4/D
HCS12 Multiplexed External Bus Interface (MEBI) Block Guide	V03	S12MEBIV3/D
HCS12 Interrupt (INT) Block Guide	V01	S12INTV1/D
HCS12 Background Debug (BDM) Block Guide	V04	S12BDMV4/D
HCS12 Breakpoint (BKP) Block Guide	V01	S12BKPV1/D
Clock and Reset Generator (CRG) Block Guide	V04	S12CRGV4/D
Enhanced Capture Timer 16 Bit 8 Channel (ECT_16B8C) Block Guide	V01	S12ECT16B8V1/D
Analog to Digital Converter 10 Bit 8 Channel (ATD_10B8C) Block Guide	V02	S12ATD10B8CV2/D
Inter IC Bus (IIC) Block Guide	V02	S12IICV2/D
Asynchronous Serial Interface (SCI) Block Guide	V02	S12SCIV2/D
Serial Peripheral Interface (SPI) Block Guide	V03	S12SPIV3/D
Pulse Width Modulator 8 Bit 8 Channel (PWM_8B8C) Block Guide	V01	S12PWM8B8CV1/D
512K Byte Flash (FTS512K4) Block Guide	V01	S12FTS512K4V1/D
4K Byte EEPROM (EETS4K) Block Guide	V02	S12EETS4KV2/D
Byte Level Data Link Controller -J1850 (BDLC) Block Guide	V01	S12BDLCV1/D
Freescale Scalable CAN (MSCAN) Block Guide	V02	S12MSCANV2/D
Voltage Regulator (VREG) Block Guide	V01	S12VREGV1/D
Port Integration Module (PIM_9DP256) Block Guide ¹	V03	S12DP256PIMV3/D
Oscillator (OSC) Block Guide	V02	S12OSCV2/D

MC9S12DP512 Device Guide V01.25

NOTES:

1. Reused due to functional equivalence.

Section 1 Introduction

1.1 Overview

The MC9S12DP512 microcontroller unit (MCU) is a 16-bit device composed of standard on-chip peripherals including a 16-bit central processing unit (HCS12 CPU), 512K bytes of Flash EEPROM, 14K bytes of RAM, 4K bytes of EEPROM, two asynchronous serial communications interfaces (SCI), three serial peripheral interfaces (SPI), an 8-channel IC/OC enhanced capture timer, two 8-channel, 10-bit analog-to-digital converters (ADC), an 8-channel pulse-width modulator (PWM), a digital Byte Data Link Controller (BDLC), 29 discrete digital I/O channels (Port A, Port B, Port K and Port E), 20 discrete digital I/O lines with interrupt and wake up capability, five CAN 2.0 A, B software compatible modules (MSCAN12), and an Inter-IC Bus. The MC9S12DP512 has full 16-bit data paths throughout. However, the external bus can operate in an 8-bit narrow mode so single 8-bit wide memory can be interfaced for lower cost systems. The inclusion of a PLL circuit allows power consumption and performance to be adjusted to suit operational requirements.

1.2 Features

- HCS12 Core
 - 16-bit HCS12 CPU
 - i. Upward compatible with M68HC11 instruction set
 - ii. Interrupt stacking and programmer's model identical to M68HC11
 - iii. Instruction queue
 - iv. Enhanced indexed addressing
 - MEBI (Multiplexed External Bus Interface)
 - MMC (Module Mapping Control)
 - INT (Interrupt control)
 - BKP (Breakpoints)
 - BDM (Background Debug Mode)
- CRG (Clock and Reset Generation)
 - Low current Colpitts oscillator or
 - Pierce oscillator
 - PLL
 - COP watchdog
 - Real Time Interrupt
 - Clock Monitor
- 8-bit and 4-bit ports with interrupt functionality

- Digital filtering
 - Programmable rising or falling edge trigger
 - Memory
 - 512K Flash EEPROM
 - 4K byte EEPROM
 - 14K byte RAM
 - Two 8-channel Analog-to-Digital Converters
 - 10-bit resolution
 - External conversion trigger capability
 - Five 1M bit per second, CAN 2.0 A, B software compatible modules
 - Five receive and three transmit buffers
 - Flexible identifier filter programmable as 2 x 32 bit, 4 x 16 bit or 8 x 8 bit
 - Four separate interrupt channels for Rx, Tx, error and wake-up
 - Low-pass filter wake-up function
 - Loop-back for self test operation
 - Enhanced Capture Timer
 - 16-bit main counter with 7-bit prescaler
 - 8 programmable input capture or output compare channels
 - Four 8-bit or two 16-bit pulse accumulators
 - 8 PWM channels
 - Programmable period and duty cycle
 - 8-bit 8-channel or 16-bit 4-channel
 - Separate control for each pulse width and duty cycle
 - Center-aligned or left-aligned outputs
 - Programmable clock select logic with a wide range of frequencies
 - Fast emergency shutdown input
 - Usable as interrupt inputs
 - Serial interfaces
 - Two asynchronous Serial Communications Interfaces (SCI)
 - Three Synchronous Serial Peripheral Interface (SPI)
 - Byte Data Link Controller (BDLC)
 - SAE J1850 Class B Data Communications Network Interface Compatible and ISO Compatible for Low-Speed (<125 Kbps) Serial Data Communications in Automotive Applications
-

- Inter-IC Bus (IIC)
 - Compatible with I²C Bus standard
 - Multi-master operation
 - Software programmable for one of 256 different serial clock frequencies
- 112-Pin LQFP package
 - I/O lines with 5V input and drive capability
 - 5V A/D converter inputs
 - Operation at 50MHz equivalent to 25MHz Bus Speed over $-40^{\circ}\text{C} \leq T_A \leq 125^{\circ}\text{C}$
 - Development support
 - Single-wire background debug™ mode (BDM)
 - On-chip hardware breakpoints

1.3 Modes of Operation

User modes

- Normal and Emulation Operating Modes
 - Normal Single-Chip Mode
 - Normal Expanded Wide Mode
 - Normal Expanded Narrow Mode
 - Emulation Expanded Wide Mode
 - Emulation Expanded Narrow Mode
- Special Operating Modes
 - Special Single-Chip Mode with active Background Debug Mode
 - Special Test Mode (**Freescale use only**)
 - Special Peripheral Mode (**Freescale use only**)

Low power modes

- Stop Mode
- Pseudo Stop Mode
- Wait Mode

1.4 Block Diagram

Figure 1-1 shows a block diagram of the MC9S12DP512 device.



Figure 1-1 MC9S12DP512 Block Diagram

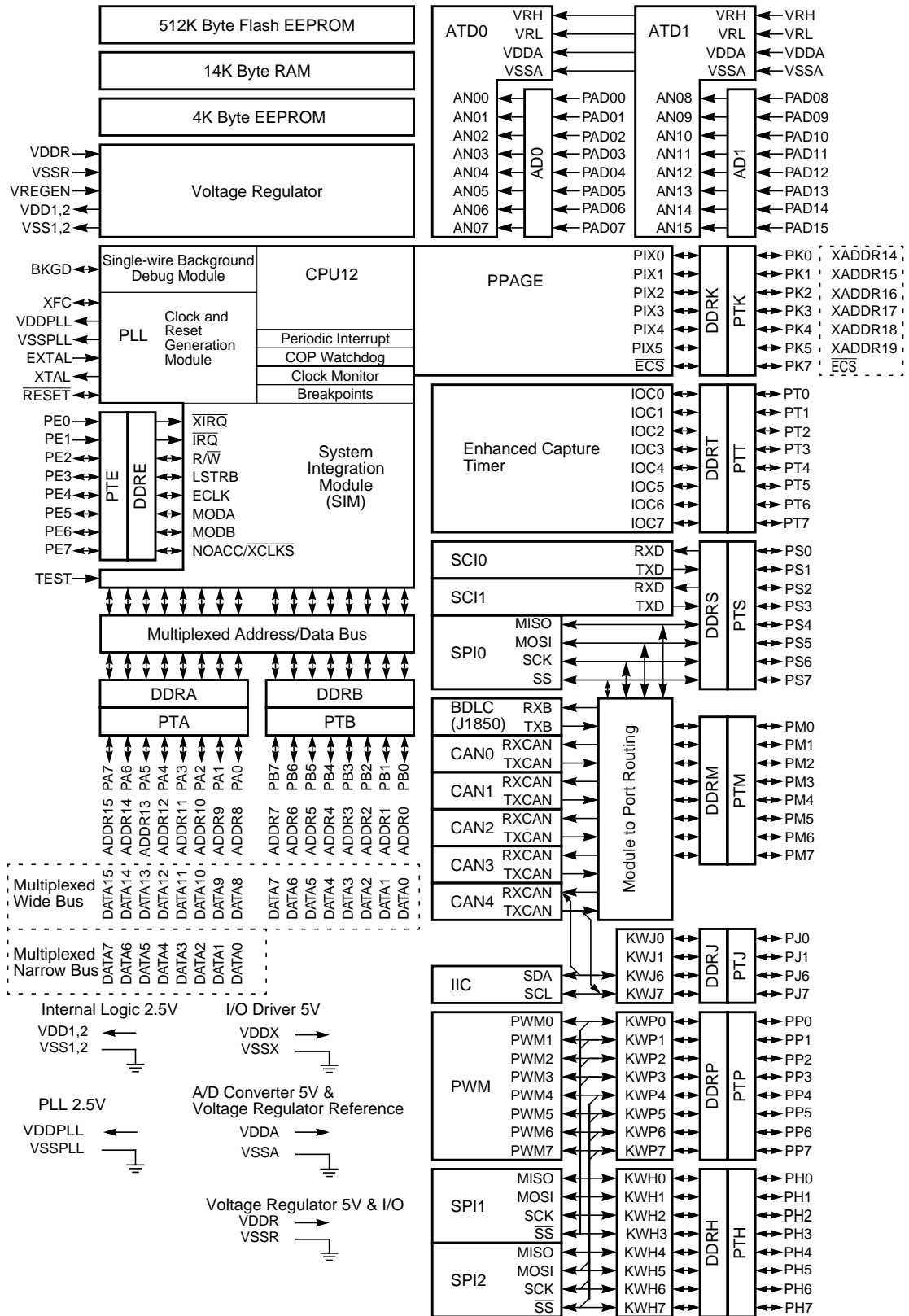

1.5 Device Memory Map

Table 1-1 and **Figure 1-2** show the device memory map of the MC9S12DP512 after reset. Note that after reset the bottom 1k of the EEPROM (\$0000 - \$03FF) are hidden by the register space

Table 1-1 Device Memory Map

Address	Module	Size (Bytes)
\$0000 - \$000F	HCS12 Multiplexed External Bus Interface	16
\$0010 - \$0014	HCS12 Module Mapping Control	5
\$0015 - \$0016	HCS12 Interrupt	2
\$0017 - \$0019	Reserved	3
\$001A - \$001B	Device ID register (PARTID)	2
\$001C - \$001D	HCS12 Module Mapping Control	2
\$001E	HCS12 Multiplexed External Bus Interface	1
\$001F	HCS12 Interrupt	1
\$0020 - \$0027	Reserved	8
\$0028 - \$002F	HCS12 Breakpoint	8
\$0030 - \$0031	HCS12 Module Mapping Control	2
\$0032 - \$0033	HCS12 Multiplexed External Bus Interface	2
\$0034 - \$003F	Clock and Reset Generator (PLL, RTI, COP)	12
\$0040 - \$007F	Enhanced Capture Timer 16-bit 8 channels	64
\$0080 - \$009F	Analog to Digital Converter 10-bit 8 channels (ATD0)	32
\$00A0 - \$00C7	Pulse Width Modulator 8-bit 8 channels (PWM)	40
\$00C8 - \$00CF	Serial Communications Interface 0 (SCI0)	8
\$00D0 - \$00D7	Serial Communications Interface 0 (SCI1)	8
\$00D8 - \$00DF	Serial Peripheral Interface (SPI0)	8
\$00E0 - \$00E7	Inter IC Bus	8
\$00E8 - \$00EF	Byte Data Link Controller (BDLC)	8
\$00F0 - \$00F7	Serial Peripheral Interface (SPI1)	8
\$00F8 - \$00FF	Serial Peripheral Interface (SPI2)	8
\$0100 - \$010F	Flash Control Register	16
\$0110 - \$011B	EEPROM Control Register	12
\$011C - \$011F	Reserved	4
\$0120 - \$013F	Analog to Digital Converter 10-bit 8 channels (ATD1)	32
\$0140 - \$017F	Freescale Scalable Can (CAN)	64
\$0180 - \$01BF	Freescale Scalable Ca	64
\$01C0 - \$01FF	Freescale Scalable Can (CAN)	64
\$0200 - \$023F	Freescale Scalable Can (CAN3)	64
\$0240 - \$027F	Port Integration Module (PIM)	64
\$0280 - \$02BF	Freescale Scalable Can (CAN4)	64
\$02C0 - \$03FF	Reserved	320
\$0000 - \$0FFF	EEPROM array	4096
\$0800 - \$3FFF	RAM array	14336
\$4000 - \$7FFF	Fixed Flash EEPROM array incl. 1K, 2K, 4K or 8K Protected Sector at start	16384

Table 1-1 Device Memory Map

Address	Module	Size (Bytes)
\$8000 - \$BFFF	Flash EEPROM Page Window	16384
\$C000 - \$FFFF	Fixed Flash EEPROM array incl. 2K, 4K, 8K or 16K Protected Sector at end and 256 bytes of Vector Space at \$FF80 - \$FFFF	16384

Figure 1-2 MC9S12DP512 Memory Map

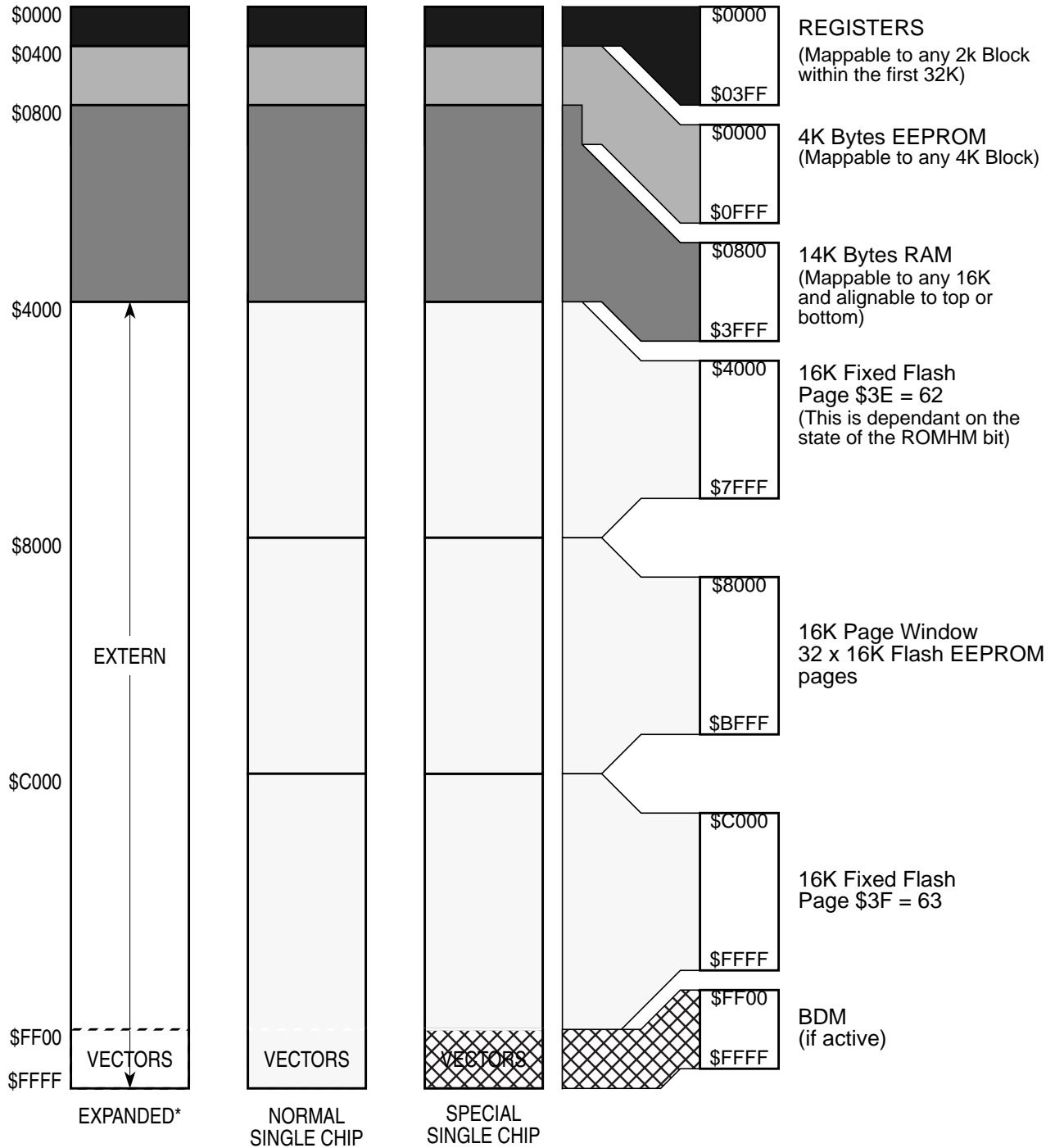

* Assuming that a '0' was driven onto port K bit 7 during MCU is reset into normal expanded wide or narrow mode.

1.5.1 Detailed Register Map

\$0000 - \$000F

MEBI map 1 of 3 (HCS12 Multiplexed External Bus Interface)

Address	Name		Bit 7	Bit 6	Bit 5	Bit 4	Bit 3	Bit 2	Bit 1	Bit 0
\$0000	PORTA	Read: Write:	Bit 7	6	5	4	3	2	1	Bit 0
\$0001	PORTB	Read: Write:	Bit 7	6	5	4	3	2	1	Bit 0
\$0002	DDRA	Read: Write:	Bit 7	6	5	4	3	2	1	Bit 0
\$0003	DDRB	Read: Write:	Bit 7	6	5	4	3	2	1	Bit 0
\$0004 - \$0007	Reserved	Read: Write:	0	0	0	0	0	0	0	0
\$0008	PORTE	Read: Write:	Bit 7	6	5	4	3	2	Bit 1	Bit 0
\$0009	DDRE	Read: Write:	Bit 7	6	5	4	3	Bit 2	0	0
\$000A	PEAR	Read: Write:	NOACCE	0	PIPOE	NECLK	LSTRE	RDWE	0	0
\$000B	MODE	Read: Write:	MODC	MODB	MODA	0	IVIS	0	EMK	EME
\$000C	PUCR	Read: Write:	PUPKE	0	0	PUPEE	0	0	PUPBE	PUPAE
\$000D	RDRIV	Read: Write:	RDPK	0	0	RDPE	0	0	RDPB	RDPA
\$000E	EBICTL	Read: Write:	0	0	0	0	0	0	0	ESTR
\$000F	Reserved	Read: Write:	0	0	0	0	0	0	0	0

\$0010 - \$0014

MMC map 1 of 4 (HCS12 Module Mapping Control)

Address	Name		Bit 7	Bit 6	Bit 5	Bit 4	Bit 3	Bit 2	Bit 1	Bit 0
\$0010	INITRM	Read: Write:	RAM15	RAM14	RAM13	RAM12	RAM11	0	0	RAMHAL
\$0011	INITRG	Read: Write:	0	REG14	REG13	REG12	REG11	0	0	0
\$0012	INITEE	Read: Write:	EE15	EE14	EE13	EE12	EE11	0	0	EEON
\$0013	MISC	Read: Write:	0	0	0	0	EXSTR1	EXSTR0	ROMHM	ROMON
\$0014	Reserved	Read: Write:	0	0	0	0	0	0	0	0

\$0015 - \$0016

INT map 1 of 2 (HCS12 Interrupt)

Address	Name	Bit 7	Bit 6	Bit 5	Bit 4	Bit 3	Bit 2	Bit 1	Bit 0
\$0015	ITCR	Read: 0	0	0	WRINT	ADR3	ADR2	ADR1	ADR0
		Write:							
\$0016	ITEST	Read: INTE	INTC	INTA	INT8	INT6	INT4	INT2	INT0
		Write:							

\$0017 - \$0019

Reserved

Address	Name	Bit 7	Bit 6	Bit 5	Bit 4	Bit 3	Bit 2	Bit 1	Bit 0
\$0017-\$0019	Reserved	Read: 0	0	0	0	0	0	0	0
		Write:							

\$001A - \$001B

Device ID Register (Table 1-3)

Address	Name	Bit 7	Bit 6	Bit 5	Bit 4	Bit 3	Bit 2	Bit 1	Bit 0
\$001A	PARTIDH	Read: ID15	ID14	ID13	ID12	ID11	ID10	ID9	ID8
		Write:							
\$001B	PARTIDL	Read: ID7	ID6	ID5	ID4	ID3	ID2	ID1	ID0
		Write:							

\$001C - \$001D

MMC map 3 of 4 (HCS12 Module Mapping Control, Table 1-4)

Address	Name	Bit 7	Bit 6	Bit 5	Bit 4	Bit 3	Bit 2	Bit 1	Bit 0
\$001C	MEMSIZ0	Read: reg_sw0	0	eep_sw1	eep_sw0	0	ram_sw2	ram_sw1	ram_sw0
		Write:							
\$001D	MEMSIZ1	Read: rom_sw1	rom_sw0	0	0	0	0	pag_sw1	pag_sw0
		Write:							

\$001E - \$001E

MEBI map 2 of 3 (HCS12 Multiplexed External Bus Interface)

Address	Name	Bit 7	Bit 6	Bit 5	Bit 4	Bit 3	Bit 2	Bit 1	Bit 0
\$001E	INTCR	Read: IRQE	IRQEN	0	0	0	0	0	0
		Write:							

\$001F - \$001F

INT map 2 of 2 (HCS12 Interrupt)

Address	Name	Bit 7	Bit 6	Bit 5	Bit 4	Bit 3	Bit 2	Bit 1	Bit 0
\$001F	HPRIO	Read: PSEL7	PSEL6	PSEL5	PSEL4	PSEL3	PSEL2	PSEL1	0
		Write:							

\$0020 - \$0027

Reserved

Address	Name	Bit 7	Bit 6	Bit 5	Bit 4	Bit 3	Bit 2	Bit 1	Bit 0
\$0020 - \$0027	Reserved	Read: 0	0	0	0	0	0	0	0
		Write:							

\$0028 - \$002F**BKP (HCS12 Breakpoint)**

Address	Name		Bit 7	Bit 6	Bit 5	Bit 4	Bit 3	Bit 2	Bit 1	Bit 0
\$0028	BKPCT0	Read:	BKEN	BKFULL	BKBDM	BKTAG	0	0	0	0
		Write:								
\$0029	BKPCT1	Read:	BK0MBH	BK0MBL	BK1MBH	BK1MBL	BK0RWE	BK0RW	BK1RWE	BK1RW
		Write:								
\$002A	BKP0X	Read:	0	0	BK0V5	BK0V4	BK0V3	BK0V2	BK0V1	BK0V0
		Write:								
\$002B	BKP0H	Read:	Bit 15	14	13	12	11	10	9	Bit 8
		Write:								
\$002C	BKP0L	Read:	Bit 7	6	5	4	3	2	1	Bit 0
		Write:								
\$002D	BKP1X	Read:	0	0	BK1V5	BK1V4	BK1V3	BK1V2	BK1V1	BK1V0
		Write:								
\$002E	BKP1H	Read:	Bit 15	14	13	12	11	10	9	Bit 8
		Write:								
\$002F	BKP1L	Read:	Bit 7	6	5	4	3	2	1	Bit 0
		Write:								

\$0030 - \$0031**MMC map 4 of 4 (HCS12 Module Mapping Control)**

Address	Name		Bit 7	Bit 6	Bit 5	Bit 4	Bit 3	Bit 2	Bit 1	Bit 0
\$0030	PPAGE	Read:	0	0	PIX5	PIX4	PIX3	PIX2	PIX1	PIX0
		Write:								
\$0031	Reserved	Read:	0	0	0	0	0	0	0	0
		Write:								

\$0032 - \$0033**MEBI map 3 of 3 (HCS12 Multiplexed External Bus Interface)**

Address	Name		Bit 7	Bit 6	Bit 5	Bit 4	Bit 3	Bit 2	Bit 1	Bit 0
\$0032	PORTK	Read:	Bit 7	6	5	4	3	2	1	Bit 0
		Write:								
\$0033	DDRK	Read:	Bit 7	6	5	4	3	2	1	Bit 0
		Write:								

\$0034 - \$003F**CRG (Clock and Reset Generator)**

Address	Name		Bit 7	Bit 6	Bit 5	Bit 4	Bit 3	Bit 2	Bit 1	Bit 0
\$0034	SYNR	Read:	0	0	SYN5	SYN4	SYN3	SYN2	SYN1	SYN0
		Write:								
\$0035	REFDV	Read:	0	0	0	0	REFDV3	REFDV2	REFDV1	REFDV0
		Write:								
\$0036	CTFLG Test Only	Read:	TOUT7	TOUT6	TOUT5	TOUT4	TOUT3	TOUT2	TOUT1	TOUT0
		Write:								
\$0037	CRGFLG	Read:	RTIF	PROF	0	LOCKIF	LOCK	TRACK	SCMIF	SCM
		Write:								
\$0038	CRGINT	Read:	RTIE	0	0	LOCKIE	0	0	SCMIE	0
		Write:								

\$0034 - \$003F

CRG (Clock and Reset Generator)

Address	Name		Bit 7	Bit 6	Bit 5	Bit 4	Bit 3	Bit 2	Bit 1	Bit 0
\$0039	CLKSEL	Read: Write:	PLLSEL	PSTP	SYSWAI	ROAWAI	PLLWAI	CWAI	RTIWAI	COPWAI
\$003A	PLLCTL	Read: Write:	CME	PLLON	AUTO	ACQ	0	PRE	PCE	SCME
\$003B	RTICTL	Read: Write:	0	RTR6	RTR5	RTR4	RTR3	RTR2	RTR1	RTR0
\$003C	COPCTL	Read: Write:	WCOP	RSBCK	0	0	0	CR2	CR1	CR0
\$003D	FORBYP Test Only	Read: Write:	RTIBYP	COPBYP	0	PLLBY	0	0	FCM	0
\$003E	CTCTL Test Only	Read: Write:	TCTL7	TCTL6	TCTL5	TCTL4	TCTL3	TCTL2	TCTL1	TCTL0
\$003F	ARMCOP	Read: Write:	0	0	0	0	0	0	0	0
			Bit 7	6	5	4	3	2	1	Bit 0

\$0040 - \$007F

ECT (Enhanced Capture Timer 16 Bit 8 Channels)

Address	Name		Bit 7	Bit 6	Bit 5	Bit 4	Bit 3	Bit 2	Bit 1	Bit 0
\$0040	TIOS	Read: Write:	IOS7	IOS6	IOS5	IOS4	IOS3	IOS2	IOS1	IOS0
\$0041	CFORC	Read: Write:	0	0	0	0	0	0	0	0
\$0042	OC7M	Read: Write:	OC7M7	OC7M6	OC7M5	OC7M4	OC7M3	OC7M2	OC7M1	OC7M0
\$0043	OC7D	Read: Write:	OC7D7	OC7D6	OC7D5	OC7D4	OC7D3	OC7D2	OC7D1	OC7D0
\$0044	TCNT (hi)	Read: Write:	Bit 15	14	13	12	11	10	9	Bit 8
\$0045	TCNT (lo)	Read: Write:	Bit 7	6	5	4	3	2	1	Bit 0
\$0046	TSCR1	Read: Write:	TEN	TSWAI	TSFRZ	TFFCA	0	0	0	0
\$0047	TTOV	Read: Write:	TOV7	TOV6	TOV5	TOV4	TOV3	TOV2	TOV1	TOV0
\$0048	TCTL1	Read: Write:	OM7	OL7	OM6	OL6	OM5	OL5	OM4	OL4
\$0049	TCTL2	Read: Write:	OM3	OL3	OM2	OL2	OM1	OL1	OM0	OL0
\$004A	TCTL3	Read: Write:	EDG7B	EDG7A	EDG6B	EDG6A	EDG5B	EDG5A	EDG4B	EDG4A
\$004B	TCTL4	Read: Write:	EDG3B	EDG3A	EDG2B	EDG2A	EDG1B	EDG1A	EDG0B	EDG0A
\$004C	TIE	Read: Write:	C7I	C6I	C5I	C4I	C3I	C2I	C1I	C0I
\$004D	TSCR2	Read: Write:	TOI	0	0	0	TCRE	PR2	PR1	PR0
\$004E	TFLG1	Read: Write:	C7F	C6F	C5F	C4F	C3F	C2F	C1F	C0F

\$0040 - \$007F**ECT (Enhanced Capture Timer 16 Bit 8 Channels)**

Address	Name		Bit 7	Bit 6	Bit 5	Bit 4	Bit 3	Bit 2	Bit 1	Bit 0
\$004F	TFLG2	Read:	TOF	0	0	0	0	0	0	0
		Write:								
\$0050	TC0 (hi)	Read:	Bit 15	14	13	12	11	10	9	Bit 8
		Write:								
\$0051	TC0 (lo)	Read:	Bit 7	6	5	4	3	2	1	Bit 0
		Write:								
\$0052	TC1 (hi)	Read:	Bit 15	14	13	12	11	10	9	Bit 8
		Write:								
\$0053	TC1 (lo)	Read:	Bit 7	6	5	4	3	2	1	Bit 0
		Write:								
\$0054	TC2 (hi)	Read:	Bit 15	14	13	12	11	10	9	Bit 8
		Write:								
\$0055	TC2 (lo)	Read:	Bit 7	6	5	4	3	2	1	Bit 0
		Write:								
\$0056	TC3 (hi)	Read:	Bit 15	14	13	12	11	10	9	Bit 8
		Write:								
\$0057	TC3 (lo)	Read:	Bit 7	6	5	4	3	2	1	Bit 0
		Write:								
\$0058	TC4 (hi)	Read:	Bit 15	14	13	12	11	10	9	Bit 8
		Write:								
\$0059	TC4 (lo)	Read:	Bit 7	6	5	4	3	2	1	Bit 0
		Write:								
\$005A	TC5 (hi)	Read:	Bit 15	14	13	12	11	10	9	Bit 8
		Write:								
\$005B	TC5 (lo)	Read:	Bit 7	6	5	4	3	2	1	Bit 0
		Write:								
\$005C	TC6 (hi)	Read:	Bit 15	14	13	12	11	10	9	Bit 8
		Write:								
\$005D	TC6 (lo)	Read:	Bit 7	6	5	4	3	2	1	Bit 0
		Write:								
\$005E	TC7 (hi)	Read:	Bit 15	14	13	12	11	10	9	Bit 8
		Write:								
\$005F	TC7 (lo)	Read:	Bit 7	6	5	4	3	2	1	Bit 0
		Write:								
\$0060	PACTL	Read:	0	PAEN	PAMOD	PEDGE	CLK1	CLK0	PAOVI	PAI
		Write:								
\$0061	PAFLG	Read:	0	0	0	0	0	0	PAOVF	PAIF
		Write:								
\$0062	PACN3 (hi)	Read:	Bit 7	6	5	4	3	2	1	Bit 0
		Write:								
\$0063	PACN2 (lo)	Read:	Bit 7	6	5	4	3	2	1	Bit 0
		Write:								
\$0064	PACN1 (hi)	Read:	Bit 7	6	5	4	3	2	1	Bit 0
		Write:								
\$0065	PACN0 (lo)	Read:	Bit 7	6	5	4	3	2	1	Bit 0
		Write:								
\$0066	MCCTL	Read:	MCZI	MODMC	RDMCL	0	0	MCEN	MCPR1	MCPR0
		Write:				ICLAT	FLMC			
\$0067	MCFLG	Read:	MCZF	0	0	0	POLF3	POLF2	POLF1	POLF0
		Write:								

\$0040 - \$007F

ECT (Enhanced Capture Timer 16 Bit 8 Channels)

Address	Name		Bit 7	Bit 6	Bit 5	Bit 4	Bit 3	Bit 2	Bit 1	Bit 0
\$0068	ICPAR	Read:	0	0	0	0	PA3EN	PA2EN	PA1EN	PA0EN
		Write:								
\$0069	DLYCT	Read:	0	0	0	0	0	0	DLY1	DLY0
		Write:								
\$006A	ICOVW	Read:	NOVW7	NOVW6	NOVW5	NOVW4	NOVW3	NOVW2	NOVW1	NOVW0
		Write:								
\$006B	ICSYS	Read:	SH37	SH26	SH15	SH04	TFMOD	PACMX	BUFEN	LATQ
		Write:								
\$006C	Reserved	Read:								
\$006D	TIMTST Test Only	Read:	0	0	0	0	0	0	TCBYP	0
		Write:								
\$006E - \$006F	Reserved	Read:								
\$0070	PBCTL	Read:	0	PBEN	0	0	0	0	PBOVI	0
		Write:								
\$0071	PBFLG	Read:	0	0	0	0	0	0	PBOVF	0
		Write:								
\$0072	PA3H	Read:	Bit 7	6	5	4	3	2	1	Bit 0
		Write:								
\$0073	PA2H	Read:	Bit 7	6	5	4	3	2	1	Bit 0
		Write:								
\$0074	PA1H	Read:	Bit 7	6	5	4	3	2	1	Bit 0
		Write:								
\$0075	PA0H	Read:	Bit 7	6	5	4	3	2	1	Bit 0
		Write:								
\$0076	MCCNT (hi)	Read:	Bit 15	14	13	12	11	10	9	Bit 8
		Write:								
\$0077	MCCNT (lo)	Read:	Bit 7	6	5	4	3	2	1	Bit 0
		Write:								
\$0078	TC0H (hi)	Read:	Bit 15	14	13	12	11	10	9	Bit 8
		Write:								
\$0079	TC0H (lo)	Read:	Bit 7	6	5	4	3	2	1	Bit 0
		Write:								
\$007A	TC1H (hi)	Read:	Bit 15	14	13	12	11	10	9	Bit 8
		Write:								
\$007B	TC1H (lo)	Read:	Bit 7	6	5	4	3	2	1	Bit 0
		Write:								
\$007C	TC2H (hi)	Read:	Bit 15	14	13	12	11	10	9	Bit 8
		Write:								
\$007D	TC2H (lo)	Read:	Bit 7	6	5	4	3	2	1	Bit 0
		Write:								
\$007E	TC3H (hi)	Read:	Bit 15	14	13	12	11	10	9	Bit 8
		Write:								
\$007F	TC3H (lo)	Read:	Bit 7	6	5	4	3	2	1	Bit 0
		Write:								

\$0080 - \$009F**ATD0 (Analog to Digital Converter 10 Bit 8 Channel)**

Address	Name		Bit 7	Bit 6	Bit 5	Bit 4	Bit 3	Bit 2	Bit 1	Bit 0
\$0080	ATD0CTL0	Read:	0	0	0	0	0	0	0	0
		Write:								
\$0081	ATD0CTL1	Read:	0	0	0	0	0	0	0	0
		Write:								
\$0082	ATD0CTL2	Read:	ADPU	AFFC	AWAI	ETRIGLE	ETRIGP	ETRIG	ASCIE	ASCIF
		Write:								
\$0083	ATD0CTL3	Read:	0	S8C	S4C	S2C	S1C	FIFO	FRZ1	FRZ0
		Write:								
\$0084	ATD0CTL4	Read:	SRES8	SMP1	SMP0	PRS4	PRS3	PRS2	PRS1	PRS0
		Write:								
\$0085	ATD0CTL5	Read:	DJM	DSGN	SCAN	MULT	0	CC	CB	CA
		Write:								
\$0086	ATD0STAT0	Read:	SCF	0	ETORF	FIFOR	0	CC2	CC1	CC0
		Write:								
\$0087	Reserved	Read:	0	0	0	0	0	0	0	0
		Write:								
\$0088	ATD0TEST0	Read:	0	0	0	0	0	0	0	0
		Write:								
\$0089	ATD0TEST1	Read:	0	0	0	0	0	0	0	SC
		Write:								
\$008A	Reserved	Read:	0	0	0	0	0	0	0	0
		Write:								
\$008B	ATD0STAT1	Read:	CCF7	CCF6	CCF5	CCF4	CCF3	CCF2	CCF1	CCF0
		Write:								
\$008C	Reserved	Read:	0	0	0	0	0	0	0	0
		Write:								
\$008D	ATD0DIEN	Read:	Bit 7	6	5	4	3	2	1	Bit 0
		Write:								
\$008E	Reserved	Read:	0	0	0	0	0	0	0	0
		Write:								
\$008F	PORTAD0	Read:	Bit 7	6	5	4	3	2	1	Bit 0
		Write:								
\$0090	ATD0DR0H	Read:	Bit 15	14	13	12	11	10	9	Bit 8
		Write:								
\$0091	ATD0DR0L	Read:	Bit 7	6	5	4	3	2	1	Bit 0
		Write:								
\$0092	ATD0DR1H	Read:	Bit 15	14	13	12	11	10	9	Bit 8
		Write:								
\$0093	ATD0DR1L	Read:	Bit 7	6	5	4	3	2	1	Bit 0
		Write:								
\$0094	ATD0DR2H	Read:	Bit 15	14	13	12	11	10	9	Bit 8
		Write:								
\$0095	ATD0DR2L	Read:	Bit 7	6	5	4	3	2	1	Bit 0
		Write:								
\$0096	ATD0DR3H	Read:	Bit 15	14	13	12	11	10	9	Bit 8
		Write:								
\$0097	ATD0DR3L	Read:	Bit 7	6	5	4	3	2	1	Bit 0
		Write:								
\$0098	ATD0DR4H	Read:	Bit 15	14	13	12	11	10	9	Bit 8
		Write:								

\$0080 - \$009F

ATD0 (Analog to Digital Converter 10 Bit 8 Channel)

Address	Name		Bit 7	Bit 6	Bit 5	Bit 4	Bit 3	Bit 2	Bit 1	Bit 0
\$0099	ATD0DR4L	Read:	Bit 7	6	5	4	3	2	1	Bit 0
		Write:								
\$009A	ATD0DR5H	Read:	Bit 15	14	13	12	11	10	9	Bit 8
		Write:								
\$009B	ATD0DR5L	Read:	Bit 7	6	5	4	3	2	1	Bit 0
		Write:								
\$009C	ATD0DR6H	Read:	Bit 15	14	13	12	11	10	9	Bit 8
		Write:								
\$009D	ATD0DR6L	Read:	Bit 7	6	5	4	3	2	1	Bit 0
		Write:								
\$009E	ATD0DR7H	Read:	Bit 15	14	13	12	11	10	9	Bit 8
		Write:								
\$009F	ATD0DR7L	Read:	Bit 7	6	5	4	3	2	1	Bit 0
		Write:								

\$00A0 - \$00C7

PWM (Pulse Width Modulator 8 Bit 8 Channel)

Address	Name		Bit 7	Bit 6	Bit 5	Bit 4	Bit 3	Bit 2	Bit 1	Bit 0
\$00A0	PWME	Read:	PWME7	PWME6	PWME5	PWME4	PWME3	PWME2	PWME1	PWME0
		Write:								
\$00A1	PWMPOL	Read:	PPOL7	PPOL6	PPOL5	PPOL4	PPOL3	PPOL2	PPOL1	PPOL0
		Write:								
\$00A2	PWMCLK	Read:	PCLK7	PCLK6	PCLK5	PCLK4	PCLK3	PCLK2	PCLK1	PCLK0
		Write:								
\$00A3	PWMPRCLK	Read:	0	PCKB2	PCKB1	PCKB0	0	PCKA2	PCKA1	PCKA0
		Write:								
\$00A4	PWMCAE	Read:	CAE7	CAE6	CAE5	CAE4	CAE3	CAE2	CAE1	CAE0
		Write:								
\$00A5	PWMCTL	Read:	CON67	CON45	CON23	CON01	PSWAI	PFRZ	0	0
		Write:								
\$00A6	PWMTST Test Only	Read:	0	0	0	0	0	0	0	0
		Write:								
\$00A7	PWMPRSC	Read:	0	0	0	0	0	0	0	0
		Write:								
\$00A8	PWMSCLA	Read:	Bit 7	6	5	4	3	2	1	Bit 0
		Write:								
\$00A9	PWMSCLB	Read:	Bit 7	6	5	4	3	2	1	Bit 0
		Write:								
\$00AA	PWMSCNTA	Read:	0	0	0	0	0	0	0	0
		Write:								
\$00AB	PWMSCNTB	Read:	0	0	0	0	0	0	0	0
		Write:								
\$00AC	PWMCNT0	Read:	Bit 7	6	5	4	3	2	1	Bit 0
		Write:	0	0	0	0	0	0	0	0
\$00AD	PWMCNT1	Read:	Bit 7	6	5	4	3	2	1	Bit 0
		Write:	0	0	0	0	0	0	0	0
\$00AE	PWMCNT2	Read:	Bit 7	6	5	4	3	2	1	Bit 0
		Write:	0	0	0	0	0	0	0	0

\$00A0 - \$00C7**PWM (Pulse Width Modulator 8 Bit 8 Channel)**

Address	Name		Bit 7	Bit 6	Bit 5	Bit 4	Bit 3	Bit 2	Bit 1	Bit 0
\$00AF	PWMCNT3	Read:	Bit 7	6	5	4	3	2	1	Bit 0
		Write:	0	0	0	0	0	0	0	0
\$00B0	PWMCNT4	Read:	Bit 7	6	5	4	3	2	1	Bit 0
		Write:	0	0	0	0	0	0	0	0
\$00B1	PWMCNT5	Read:	Bit 7	6	5	4	3	2	1	Bit 0
		Write:	0	0	0	0	0	0	0	0
\$00B2	PWMCNT6	Read:	Bit 7	6	5	4	3	2	1	Bit 0
		Write:	0	0	0	0	0	0	0	0
\$00B3	PWMCNT7	Read:	Bit 7	6	5	4	3	2	1	Bit 0
		Write:	0	0	0	0	0	0	0	0
\$00B4	PWMPER0	Read:	Bit 7	6	5	4	3	2	1	Bit 0
		Write:	0	0	0	0	0	0	0	0
\$00B5	PWMPER1	Read:	Bit 7	6	5	4	3	2	1	Bit 0
		Write:	0	0	0	0	0	0	0	0
\$00B6	PWMPER2	Read:	Bit 7	6	5	4	3	2	1	Bit 0
		Write:	0	0	0	0	0	0	0	0
\$00B7	PWMPER3	Read:	Bit 7	6	5	4	3	2	1	Bit 0
		Write:	0	0	0	0	0	0	0	0
\$00B8	PWMPER4	Read:	Bit 7	6	5	4	3	2	1	Bit 0
		Write:	0	0	0	0	0	0	0	0
\$00B9	PWMPER5	Read:	Bit 7	6	5	4	3	2	1	Bit 0
		Write:	0	0	0	0	0	0	0	0
\$00BA	PWMPER6	Read:	Bit 7	6	5	4	3	2	1	Bit 0
		Write:	0	0	0	0	0	0	0	0
\$00BB	PWMPER7	Read:	Bit 7	6	5	4	3	2	1	Bit 0
		Write:	0	0	0	0	0	0	0	0
\$00BC	PWMDTY0	Read:	Bit 7	6	5	4	3	2	1	Bit 0
		Write:	0	0	0	0	0	0	0	0
\$00BD	PWMDTY1	Read:	Bit 7	6	5	4	3	2	1	Bit 0
		Write:	0	0	0	0	0	0	0	0
\$00BE	PWMDTY2	Read:	Bit 7	6	5	4	3	2	1	Bit 0
		Write:	0	0	0	0	0	0	0	0
\$00BF	PWMDTY3	Read:	Bit 7	6	5	4	3	2	1	Bit 0
		Write:	0	0	0	0	0	0	0	0
\$00C0	PWMDTY4	Read:	Bit 7	6	5	4	3	2	1	Bit 0
		Write:	0	0	0	0	0	0	0	0
\$00C1	PWMDTY5	Read:	Bit 7	6	5	4	3	2	1	Bit 0
		Write:	0	0	0	0	0	0	0	0
\$00C2	PWMDTY6	Read:	Bit 7	6	5	4	3	2	1	Bit 0
		Write:	0	0	0	0	0	0	0	0
\$00C3	PWMDTY7	Read:	Bit 7	6	5	4	3	2	1	Bit 0
		Write:	0	0	0	0	0	0	0	0
\$00C4	PWMSDN	Read:	PWMIF	PWMIE	PWM RSTRT	PWMLVL	0	PWM7IN	PWM7 INL	PWM7 ENA
		Write:	0	0	0	0	0	0	0	0
\$00C5 - \$00C7	Reserved	Read:	0	0	0	0	0	0	0	0
		Write:	0	0	0	0	0	0	0	0

\$00C8 - \$00CF

SCI0 (Asynchronous Serial Interface)

Address	Name		Bit 7	Bit 6	Bit 5	Bit 4	Bit 3	Bit 2	Bit 1	Bit 0
\$00C8	SCI0BDH	Read:	0	0	0	SBR12	SBR11	SBR10	SBR9	SBR8
		Write:								
\$00C9	SCI0BDL	Read:	SBR7	SBR6	SBR5	SBR4	SBR3	SBR2	SBR1	SBR0
		Write:								
\$00CA	SC0CR1	Read:	LOOPS	SCISWAI	RSRC	M	WAKE	ILT	PE	PT
		Write:								
\$00CB	SCI0CR2	Read:	TIE	TCIE	RIE	ILIE	TE	RE	RWU	SBK
		Write:								
\$00CC	SCI0SR1	Read:	TDRE	TC	RDRF	IDLE	OR	NF	FE	PF
		Write:								
\$00CD	SC0SR2	Read:	0	0	0	0	0	BRK13	TXDIR	RAF
		Write:								
\$00CE	SCI0DRH	Read:	R8	T8	0	0	0	0	0	0
		Write:								
\$00CF	SCI0DRL	Read:	R7	R6	R5	R4	R3	R2	R1	R0
		Write:	T7	T6	T5	T4	T3	T2	T1	T0

\$00D0 - \$00D7

SCI1 (Asynchronous Serial Interface)

Address	Name		Bit 7	Bit 6	Bit 5	Bit 4	Bit 3	Bit 2	Bit 1	Bit 0
\$00D0	SCI1BDH	Read:	0	0	0	SBR12	SBR11	SBR10	SBR9	SBR8
		Write:								
\$00D1	SCI1BDL	Read:	SBR7	SBR6	SBR5	SBR4	SBR3	SBR2	SBR1	SBR0
		Write:								
\$00D2	SC1CR1	Read:	LOOPS	SCISWAI	RSRC	M	WAKE	ILT	PE	PT
		Write:								
\$00D3	SCI1CR2	Read:	TIE	TCIE	RIE	ILIE	TE	RE	RWU	SBK
		Write:								
\$00D4	SCI1SR1	Read:	TDRE	TC	RDRF	IDLE	OR	NF	FE	PF
		Write:								
\$00D5	SC1SR2	Read:	0	0	0	0	0	BRK13	TXDIR	RAF
		Write:								
\$00D6	SCI1DRH	Read:	R8	T8	0	0	0	0	0	0
		Write:								
\$00D7	SCI1DRL	Read:	R7	R6	R5	R4	R3	R2	R1	R0
		Write:	T7	T6	T5	T4	T3	T2	T1	T0

\$00D8 - \$00DF

SPI0 (Serial Peripheral Interface)

Address	Name		Bit 7	Bit 6	Bit 5	Bit 4	Bit 3	Bit 2	Bit 1	Bit 0
\$00D8	SPI0CR1	Read:	SPIE	SPE	SPTIE	MSTR	CPOL	CPHA	SSOE	LSBFE
		Write:								
\$00D9	SPI0CR2	Read:	0	0	0	MODFEN	BIDIROE	0	SPISWAI	SPC0
		Write:								
\$00DA	SPI0BR	Read:	0	SPPR2	SPPR1	SPPR0	0	SPR2	SPR1	SPR0
		Write:								
\$00DB	SPI0SR	Read:	SPIF	0	SPTEF	MODF	0	0	0	0
		Write:								

\$00D8 - \$00DF**SPI0 (Serial Peripheral Interface)**

Address	Name		Bit 7	Bit 6	Bit 5	Bit 4	Bit 3	Bit 2	Bit 1	Bit 0
\$00DC	Reserved	Read:	0	0	0	0	0	0	0	0
		Write:								
\$00DD	SPI0DR	Read:	Bit 7	6	5	4	3	2	1	Bit 0
		Write:								
\$00DE - \$00DF	Reserved	Read:	0	0	0	0	0	0	0	0
		Write:								

\$00E0 - \$00E7**IIC (Inter IC Bus)**

Address	Name		Bit 7	Bit 6	Bit 5	Bit 4	Bit 3	Bit 2	Bit 1	Bit 0
\$00E0	IBAD	Read:	ADR7	ADR6	ADR5	ADR4	ADR3	ADR2	ADR1	0
		Write:								
\$00E1	IBFD	Read:	IBC7	IBC6	IBC5	IBC4	IBC3	IBC2	IBC1	IBC0
		Write:								
\$00E2	IBCR	Read:	IBEN	IBIE	MS/ \overline{S} L	TX/ \overline{R} X	TXAK	0	0	IBSWAI
		Write:						RSTA		
\$00E3	IBSR	Read:	TCF	IAAS	IBB	IBAL	0	SRW	IBIF	RXAK
		Write:								
\$00E4	IBDR	Read:	D7	D6	D5	D4	D3	D2	D1	D0
		Write:								
\$00E5 - \$00E7	Reserved	Read:	0	0	0	0	0	0	0	0
		Write:								

\$00E8 - \$00EF**BDLC (Bytelevel Data Link Controller J1850)**

Address	Name		Bit 7	Bit 6	Bit 5	Bit 4	Bit 3	Bit 2	Bit 1	Bit 0
\$00E8	DLCBCR1	Read:	IMSG	CLKS	0	0	0	0	IE	WCM
		Write:								
\$00E9	DLCBSVR	Read:	0	0	I3	I2	I1	I0	0	0
		Write:								
\$00EA	DLCBCR2	Read:	SMRST	DLOOP	RX4XE	NBFS	TEOD	TSIFR	TMIFR1	TMIFR0
		Write:								
\$00EB	DLCBDR	Read:	D7	D6	D5	D4	D3	D2	D1	D0
		Write:								
\$00EC	DLCBARD	Read:	0	RXPOL	0	0	BO3	BO2	BO1	BO0
		Write:								
\$00ED	DLCBRSR	Read:	0	0	R5	R4	R3	R2	R1	R0
		Write:								
\$00EE	DLCSCR	Read:	0	0	0	BDLCE	0	0	0	0
		Write:								
\$00EF	DLCBSTAT	Read:	0	0	0	0	0	0	0	IDLE
		Write:								

\$00F0 - \$00F7

SPI1 (Serial Peripheral Interface)

Address	Name		Bit 7	Bit 6	Bit 5	Bit 4	Bit 3	Bit 2	Bit 1	Bit 0
\$00F0	SPI1CR1	Read:	SPIE	SPE	SPTIE	MSTR	CPOL	CPHA	SSOE	LSBFE
		Write:								
\$00F1	SPI1CR2	Read:	0	0	0	MODFEN	BIDIROE	0	SPISWAI	SPC0
		Write:								
\$00F2	SPI1BR	Read:	0	SPPR2	SPPR1	SPPR0	0	SPR2	SPR1	SPR0
		Write:								
\$00F3	SPI1SR	Read:	SPIF	0	SPTEF	MODF	0	0	0	0
		Write:								
\$00F4	Reserved	Read:	0	0	0	0	0	0	0	0
		Write:								
\$00F5	SPI1DR	Read:	Bit 7	6	5	4	3	2	1	Bit 0
		Write:								
\$00F6 - \$00F7	Reserved	Read:	0	0	0	0	0	0	0	0
		Write:								

\$00F8 - \$00FF

SPI2 (Serial Peripheral Interface)

Address	Name		Bit 7	Bit 6	Bit 5	Bit 4	Bit 3	Bit 2	Bit 1	Bit 0
\$00F8	SPI2CR1	Read:	SPIE	SPE	SPTIE	MSTR	CPOL	CPHA	SSOE	LSBFE
		Write:								
\$00F9	SPI2CR2	Read:	0	0	0	MODFEN	BIDIROE	0	SPISWAI	SPC0
		Write:								
\$00FA	SPI2BR	Read:	0	SPPR2	SPPR1	SPPR0	0	SPR2	SPR1	SPR0
		Write:								
\$00FB	SPI2SR	Read:	SPIF	0	SPTEF	MODF	0	0	0	0
		Write:								
\$00FC	Reserved	Read:	0	0	0	0	0	0	0	0
		Write:								
\$00FD	SPI2DR	Read:	Bit 7	6	5	4	3	2	1	Bit 0
		Write:								
\$00FE - \$00FF	Reserved	Read:	0	0	0	0	0	0	0	0
		Write:								

\$0100 - \$010F

Flash Control Register (fts512k4)

Address	Name		Bit 7	Bit 6	Bit 5	Bit 4	Bit 3	Bit 2	Bit 1	Bit 0
\$0100	FCLKDIV	Read:	FDIVLD	PRDIV8	FDIV5	FDIV4	FDIV3	FDIV2	FDIV1	FDIV0
		Write:								
\$0101	FSEC	Read:	KEYEN1	KEYEN0	NV5	NV4	NV3	NV2	SEC1	SEC0
		Write:								
\$0102	FTSTMOD	Read:	0	0	0	WRALL	0	0	0	0
		Write:								
\$0103	FCNFG	Read:	CBEIE	CCIE	KEYACC	0	0	0	BKSEL1	BKSEL0
		Write:								
\$0104	FPROT	Read:	FPOPEN	NV6	FPHDIS	FPHS1	FPHS0	FPLDIS	FPLS1	FPLS0
		Write:								
\$0105	FSTAT	Read:	CBEIF	CCIF	PVIOL	ACCERR	0	BLANK	0	0
		Write:								

\$0100 - \$010F**Flash Control Register (fts512k4)**

Address	Name	Read:	Bit 7	Bit 6	Bit 5	Bit 4	Bit 3	Bit 2	Bit 1	Bit 0
\$0106	FCMD	Read:	0	CMDB6	CMDB5	0	0	CMDB2	0	CMDB0
		Write:								
\$0107	Reserved	Read:	0	0	0	0	0	0	0	0
		Write:								
\$0108	FADDRHI	Read:	Bit 15	14	13	12	11	10	9	Bit 8
		Write:								
\$0109	FADDRLO	Read:	Bit 7	6	5	4	3	2	1	Bit 0
		Write:								
\$010A	FDATAHI	Read:	Bit 15	14	13	12	11	10	9	Bit 8
		Write:								
\$010B	FDATALO	Read:	Bit 7	6	5	4	3	2	1	Bit 0
		Write:								
\$010C - \$010F	Reserved	Read:	0	0	0	0	0	0	0	0
		Write:								

\$0110 - \$011B**EEPROM Control Register (eets4k)**

Address	Name	Read:	Bit 7	Bit 6	Bit 5	Bit 4	Bit 3	Bit 2	Bit 1	Bit 0
\$0110	ECLKDIV	Read:	EDIVLD	PRDIV8	EDIV5	EDIV4	EDIV3	EDIV2	EDIV1	EDIV0
		Write:								
\$0111 - \$0112	Reserved	Read:	0	0	0	0	0	0	0	0
		Write:								
\$0113	ECNFG	Read:	CBEIE	CCIE	0	0	0	0	0	0
		Write:								
\$0114	EPROT	Read:	EPOPEN	NV6	NV5	NV4	EPDIS	EP2	EP1	EP0
		Write:								
\$0115	ESTAT	Read:	CBEIF	CCIF	PVIOL	ACCERR	0	BLANK	0	0
		Write:								
\$0116	ECMD	Read:	0	CMDB6	CMDB5	0	0	CMDB2	0	CMDB0
		Write:								
\$0117	Reserved	Read:	0	0	0	0	0	0	0	0
		Write:								
\$0118	EADDRHI	Read:	0	0	0	0	0	10	9	Bit 8
		Write:								
\$0119	EADDRLO	Read:	Bit 7	6	5	4	3	2	1	Bit 0
		Write:								
\$011A	EDATAHI	Read:	Bit 15	14	13	12	11	10	9	Bit 8
		Write:								
\$011B	EDATALO	Read:	Bit 7	6	5	4	3	2	1	Bit 0
		Write:								

\$011C - \$011F**Reserved for RAM Control Register**

Address	Name	Read:	Bit 7	Bit 6	Bit 5	Bit 4	Bit 3	Bit 2	Bit 1	Bit 0
\$011C - \$011F	Reserved	Read:	0	0	0	0	0	0	0	0
		Write:								

\$0120 - \$013F

ATD1 (Analog to Digital Converter 10 Bit 8 Channel)

Address	Name		Bit 7	Bit 6	Bit 5	Bit 4	Bit 3	Bit 2	Bit 1	Bit 0
\$0120	ATD1CTL0	Read:	0	0	0	0	0	0	0	0
		Write:								
\$0121	ATD1CTL1	Read:	0	0	0	0	0	0	0	0
		Write:								
\$0122	ATD1CTL2	Read:	ADPU	AFFC	AWAI	ETRIGLE	ETRIGP	ETRIG	ASCIE	ASCIF
		Write:								
\$0123	ATD1CTL3	Read:	0	S8C	S4C	S2C	S1C	FIFO	FRZ1	FRZ0
		Write:								
\$0124	ATD1CTL4	Read:	SRES8	SMP1	SMP0	PRS4	PRS3	PRS2	PRS1	PRS0
		Write:								
\$0125	ATD1CTL5	Read:	DJM	DSGN	SCAN	MULT	0	CC	CB	CA
		Write:								
\$0126	ATD1STAT0	Read:	SCF	0	ETORF	FIFOR	0	CC2	CC1	CC0
		Write:								
\$0127	Reserved	Read:	0	0	0	0	0	0	0	0
		Write:								
\$0128	ATD1TEST0	Read:	0	0	0	0	0	0	0	0
		Write:								
\$0129	ATD1TEST1	Read:	0	0	0	0	0	0	0	SC
		Write:								
\$012A	Reserved	Read:	0	0	0	0	0	0	0	0
		Write:								
\$012B	ATD1STAT1	Read:	CCF7	CCF6	CCF5	CCF4	CCF3	CCF2	CCF1	CCF0
		Write:								
\$012C	Reserved	Read:	0	0	0	0	0	0	0	0
		Write:								
\$012D	ATD1DIEN	Read:	Bit 7	6	5	4	3	2	1	Bit 0
		Write:								
\$012E	Reserved	Read:	0	0	0	0	0	0	0	0
		Write:								
\$012F	PORTAD1	Read:	Bit 7	6	5	4	3	2	1	Bit 0
		Write:								
\$0130	ATD1DR0H	Read:	Bit 15	14	13	12	11	10	9	Bit 8
		Write:								
\$0131	ATD1DR0L	Read:	Bit 7	6	5	4	3	2	1	Bit 0
		Write:								
\$0132	ATD1DR1H	Read:	Bit 15	14	13	12	11	10	9	Bit 8
		Write:								
\$0133	ATD1DR1L	Read:	Bit 7	6	5	4	3	2	1	Bit 0
		Write:								
\$0134	ATD1DR2H	Read:	Bit 15	14	13	12	11	10	9	Bit 8
		Write:								
\$0135	ATD1DR2L	Read:	Bit 7	6	5	4	3	2	1	Bit 0
		Write:								
\$0136	ATD1DR3H	Read:	Bit 15	14	13	12	11	10	9	Bit 8
		Write:								
\$0137	ATD1DR3L	Read:	Bit 7	6	5	4	3	2	1	Bit 0
		Write:								
\$0138	ATD1DR4H	Read:	Bit 15	14	13	12	11	10	9	Bit 8
		Write:								

\$0120 - \$013F**ATD1 (Analog to Digital Converter 10 Bit 8 Channel)**

Address	Name		Bit 7	Bit 6	Bit 5	Bit 4	Bit 3	Bit 2	Bit 1	Bit 0
\$0139	ATD1DR4L	Read:	Bit 7	6	5	4	3	2	1	Bit 0
		Write:								
\$013A	ATD1DR5H	Read:	Bit 15	14	13	12	11	10	9	Bit 8
		Write:								
\$013B	ATD1DR5L	Read:	Bit 7	6	5	4	3	2	1	Bit 0
		Write:								
\$013C	ATD1DR6H	Read:	Bit 15	14	13	12	11	10	9	Bit 8
		Write:								
\$013D	ATD1DR6L	Read:	Bit 7	6	5	4	3	2	1	Bit 0
		Write:								
\$013E	ATD1DR7H	Read:	Bit 15	14	13	12	11	10	9	Bit 8
		Write:								
\$013F	ATD1DR7L	Read:	Bit 7	6	5	4	3	2	1	Bit 0
		Write:								

\$0140 - \$017F**CAN0 (Freescale Scalable CAN - FSCAN)**

Address	Name		Bit 7	Bit 6	Bit 5	Bit 4	Bit 3	Bit 2	Bit 1	Bit 0
\$0140	CAN0CTL0	Read:	RXFRM	RXACT	CSWAI	SYNCH	TIME	WUPE	SLPRQ	INITRQ
		Write:								
\$0141	CAN0CTL1	Read:	CANE	CLKSRC	LOOPB	LISTEN	0	WUPM	SLPAK	INITAK
		Write:								
\$0142	CAN0BTR0	Read:	SJW1	SJW0	BRP5	BRP4	BRP3	BRP2	BRP1	BRP0
		Write:								
\$0143	CAN0BTR1	Read:	SAMP	TSEG22	TSEG21	TSEG20	TSEG13	TSEG12	TSEG11	TSEG10
		Write:								
\$0144	CAN0RFLG	Read:	WUPIF	CSCIF	RSTAT1	RSTAT0	TSTAT1	TSTAT0	OVRIF	RXF
		Write:								
\$0145	CAN0RIER	Read:	WUPIE	CSCIE	RSTATE1	RSTATE0	TSTATE1	TSTATE0	OVRIE	RXFIE
		Write:								
\$0146	CAN0TFLG	Read:	0	0	0	0	0	TXE2	TXE1	TXE0
		Write:								
\$0147	CAN0TIER	Read:	0	0	0	0	0	TXEIE2	TXEIE1	TXEIE0
		Write:								
\$0148	CAN0TARQ	Read:	0	0	0	0	0	ABTRQ2	ABTRQ1	ABTRQ0
		Write:								
\$0149	CAN0TAAK	Read:	0	0	0	0	0	ABTAK2	ABTAK1	ABTAK0
		Write:								
\$014A	CAN0TBSEL	Read:	0	0	0	0	0	TX2	TX1	TX0
		Write:								
\$014B	CAN0IDAC	Read:	0	0	IDAM1	IDAM0	0	IDHIT2	IDHIT1	IDHIT0
		Write:								
\$014C - \$014D	Reserved	Read:	0	0	0	0	0	0	0	0
		Write:								
\$014E	CAN0RXERR	Read:	RXERR7	RXERR6	RXERR5	RXERR4	RXERR3	RXERR2	RXERR1	RXERR0
		Write:								
\$014F	CAN0TXERR	Read:	TXERR7	TXERR6	TXERR5	TXERR4	TXERR3	TXERR2	TXERR1	TXERR0
		Write:								
\$0150 - \$0153	CAN0IDAR0 - CAN0IDAR3	Read:	AC7	AC6	AC5	AC4	AC3	AC2	AC1	AC0
		Write:								

\$0140 - \$017F

CAN0 (Freescale Scalable CAN - MSCAN)

Address	Name		Bit 7	Bit 6	Bit 5	Bit 4	Bit 3	Bit 2	Bit 1	Bit 0
\$0154 -	CAN0IDMR0 -	Read:	AM7	AM6	AM5	AM4	AM3	AM2	AM1	AM0
\$0157	CAN0IDMR3	Write:								
\$0158 -	CAN0IDAR4 -	Read:	AC7	AC6	AC5	AC4	AC3	AC2	AC1	AC0
\$015B	CAN0IDAR7	Write:								
\$015C -	CAN0IDMR4 -	Read:	AM7	AM6	AM5	AM4	AM3	AM2	AM1	AM0
\$015F	CAN0IDMR7	Write:								
\$0160 -	CAN0RXFG	Read:	FOREGROUND RECEIVE BUFFER see Table 1-2							
\$016F		Write:								
\$0170 -	CAN0TXFG	Read:	FOREGROUND TRANSMIT BUFFER see Table 1-2							
\$017F		Write:								

Table 1-2 Detailed MSCAN Foreground Receive and Transmit Buffer Layout

Address	Name		Bit 7	Bit 6	Bit 5	Bit 4	Bit 3	Bit 2	Bit 1	Bit 0
\$xxx0	Extended ID	Read:	ID28	ID27	ID26	ID25	ID24	ID23	ID22	ID21
	Standard ID	Read:	ID10	ID9	ID8	ID7	ID6	ID5	ID4	ID3
\$xxx1	CANxRIDR0	Write:								
	Extended ID	Read:	ID20	ID19	ID18	SRR=1	IDE=1	ID17	ID16	ID15
	Standard ID	Read:	ID2	ID1	ID0	RTR	IDE=0			
	CANxRIDR1	Write:								
\$xxx2	Extended ID	Read:	ID14	ID13	ID12	ID11	ID10	ID9	ID8	ID7
	Standard ID	Read:								
\$xxx3	CANxRIDR2	Write:								
	Extended ID	Read:	ID6	ID5	ID4	ID3	ID2	ID1	ID0	RTR
\$xxx4 -	CANxRDSR0 -	Read:	DB7	DB6	DB5	DB4	DB3	DB2	DB1	DB0
		\$xxxB	Write:							
\$xxxC	CANRxDLR	Read:					DLC3	DLC2	DLC1	DLC0
		Write:								
\$xxxD	Reserved	Read:								
		Write:								
\$xxxE	CANxRTSRH	Read:	TSR15	TSR14	TSR13	TSR12	TSR11	TSR10	TSR9	TSR8
		Write:								
\$xxxF	CANxRTSRL	Read:	TSR7	TSR6	TSR5	TSR4	TSR3	TSR2	TSR1	TSR0
		Write:								
\$xx10	Extended ID	Read:	ID28	ID27	ID26	ID25	ID24	ID23	ID22	ID21
	CANxTIDR0	Write:								
\$xx11	Standard ID	Read:	ID10	ID9	ID8	ID7	ID6	ID5	ID4	ID3
	Write:									
	Extended ID	Read:	ID20	ID19	ID18	SRR=1	IDE=1	ID17	ID16	ID15
	CANxTIDR1	Write:								
\$xx12	Standard ID	Read:	ID2	ID1	ID0	RTR	IDE=0			
	Write:									
\$xx12	Extended ID	Read:	ID14	ID13	ID12	ID11	ID10	ID9	ID8	ID7
	CANxTIDR2	Write:								
\$xx12	Standard ID	Read:								
	Write:									

Table 1-2 Detailed FSCAN Foreground Receive and Transmit Buffer Layout

Address	Name		Bit 7	Bit 6	Bit 5	Bit 4	Bit 3	Bit 2	Bit 1	Bit 0
\$xx13	CANxTIDR3	Read:	ID6	ID5	ID4	ID3	ID2	ID1	ID0	RTR
		Write:								
\$xx14 - \$xx1B	CANxTDSR0 - CANxTDSR7	Read:	DB7	DB6	DB5	DB4	DB3	DB2	DB1	DB0
		Write:								
\$xx1C	CANxTDLR	Read:					DLC3	DLC2	DLC1	DLC0
		Write:								
\$xx1D	CANxTTBPR	Read:	PRI07	PRI06	PRI05	PRI04	PRI03	PRI02	PRI01	PRI00
		Write:								
\$xx1E	CANxTTSRH	Read:	TSR15	TSR14	TSR13	TSR12	TSR11	TSR10	TSR9	TSR8
		Write:								
\$xx1F	CANxTTSRL	Read:	TSR7	TSR6	TSR5	TSR4	TSR3	TSR2	TSR1	TSR0
		Write:								

\$0180 - \$01BF**CAN1 (Freescale Scalable CAN - FSCAN)**

Address	Name		Bit 7	Bit 6	Bit 5	Bit 4	Bit 3	Bit 2	Bit 1	Bit 0
\$0180	CAN1CTL0	Read:	RXFRM	RXACT	CSWAI	SYNCH	TIME	WUPE	SLPRQ	INITRQ
		Write:								
\$0181	CAN1CTL1	Read:	CANE	CLKSRC	LOOPB	LISTEN	0	WUPM	SLPAK	INITAK
		Write:								
\$0182	CAN1BTR0	Read:	SJW1	SJW0	BRP5	BRP4	BRP3	BRP2	BRP1	BRP0
		Write:								
\$0183	CAN1BTR1	Read:	SAMP	TSEG22	TSEG21	TSEG20	TSEG13	TSEG12	TSEG11	TSEG10
		Write:								
\$0184	CAN1RFLG	Read:	WUPIF	CSCIF	RSTAT1	RSTAT0	TSTAT1	TSTAT0	OVRIF	RXF
		Write:								
\$0185	CAN1RIER	Read:	WUPIE	CSCIE	RSTATE1	RSTATE0	TSTATE1	TSTATE0	OVRIE	RXFIE
		Write:								
\$0186	CAN1TFLG	Read:	0	0	0	0	0	TXE2	TXE1	TXE0
		Write:								
\$0187	CAN1TIER	Read:	0	0	0	0	0	TXEIE2	TXEIE1	TXEIE0
		Write:								
\$0188	CAN1TARQ	Read:	0	0	0	0	0	ABTRQ2	ABTRQ1	ABTRQ0
		Write:								
\$0189	CAN1TAAK	Read:	0	0	0	0	0	ABTAK2	ABTAK1	ABTAK0
		Write:								
\$018A	CAN1TBSEL	Read:	0	0	0	0	0	TX2	TX1	TX0
		Write:								
\$018B	CAN1IDAC	Read:	0	0	IDAM1	IDAM0	0	IDHIT2	IDHIT1	IDHIT0
		Write:								
\$018C - \$018D	Reserved	Read:	0	0	0	0	0	0	0	0
		Write:								
\$018E	CAN1RXERR	Read:	RXERR7	RXERR6	RXERR5	RXERR4	RXERR3	RXERR2	RXERR1	RXERR0
		Write:								
\$018F	CAN1TXERR	Read:	TXERR7	TXERR6	TXERR5	TXERR4	TXERR3	TXERR2	TXERR1	TXERR0
		Write:								
\$0190 - \$0193	CAN1IDAR0 - CAN1IDAR3	Read:	AC7	AC6	AC5	AC4	AC3	AC2	AC1	AC0
		Write:								

\$0180 - \$01BF

CAN1 (Freescale Scalable CAN - FSCAN)

Address	Name	Read:	Bit 7	Bit 6	Bit 5	Bit 4	Bit 3	Bit 2	Bit 1	Bit 0
\$0194 -	CAN1IDMR0 -	Read:	AM7	AM6	AM5	AM4	AM3	AM2	AM1	AM0
\$0197	CAN1IDMR3	Write:								
\$0198 -	CAN1IDAR4 -	Read:	AC7	AC6	AC5	AC4	AC3	AC2	AC1	AC0
\$019B	CAN1IDAR7	Write:								
\$019C -	CAN1IDMR4 -	Read:	AM7	AM6	AM5	AM4	AM3	AM2	AM1	AM0
\$019F	CAN1IDMR7	Write:								
\$01A0 -	CAN1RXFG	Read:	FOREGROUND RECEIVE BUFFER see Table 1-2							
\$01AF		Write:								
\$01B0 -	CAN1TXFG	Read:	FOREGROUND TRANSMIT BUFFER see Table 1-2							
\$01BF		Write:								

\$01C0 - \$01FF

CAN2 (Freescale Scalable CAN - FSCAN)

Address	Name	Read:	Bit 7	Bit 6	Bit 5	Bit 4	Bit 3	Bit 2	Bit 1	Bit 0
\$01C0	CAN2CTL0	Read:	RXFRM	RXACT	CSWAI	SYNCH	TIME	WUPE	SLPRQ	INITRQ
		Write:								
\$01C1	CAN2CTL1	Read:	CANE	CLKSRC	LOOPB	LISTEN	0	WUPM	SLPAK	INITAK
		Write:								
\$01C2	CAN2BTR0	Read:	SJW1	SJW0	BRP5	BRP4	BRP3	BRP2	BRP1	BRP0
		Write:								
\$01C3	CAN2BTR1	Read:	SAMP	TSEG22	TSEG21	TSEG20	TSEG13	TSEG12	TSEG11	TSEG10
		Write:								
\$01C4	CAN2RFLG	Read:	WUPIF	CSCIF	RSTAT1	RSTAT0	TSTAT1	TSTAT0	OVRIF	RXF
		Write:								
\$01C5	CAN2RIER	Read:	WUPIE	CSCIE	RSTATE1	RSTATE0	TSTATE1	TSTATE0	OVRIE	RXFIE
		Write:								
\$01C6	CAN2TFLG	Read:	0	0	0	0	0	TXE2	TXE1	TXE0
		Write:								
\$01C7	CAN2TIER	Read:	0	0	0	0	0	TXEIE2	TXEIE1	TXEIE0
		Write:								
\$01C8	CAN2TARQ	Read:	0	0	0	0	0	ABTRQ2	ABTRQ1	ABTRQ0
		Write:								
\$01C9	CAN2TAAK	Read:	0	0	0	0	0	ABTAK2	ABTAK1	ABTAK0
		Write:								
\$01CA	CAN2TBSEL	Read:	0	0	0	0	0	TX2	TX1	TX0
		Write:								
\$01CB	CAN2IDAC	Read:	0	0	IDAM1	IDAM0	0	IDHIT2	IDHIT1	IDHIT0
		Write:								
\$01CC -	Reserved	Read:	0	0	0	0	0	0	0	0
\$01CD		Write:								
\$01CE	CAN2RXERR	Read:	RXERR7	RXERR6	RXERR5	RXERR4	RXERR3	RXERR2	RXERR1	RXERR0
		Write:								
\$01CF	CAN2TXERR	Read:	TXERR7	TXERR6	TXERR5	TXERR4	TXERR3	TXERR2	TXERR1	TXERR0
		Write:								
\$01D0 -	CAN2IDAR0 -	Read:	AC7	AC6	AC5	AC4	AC3	AC2	AC1	AC0
\$01D3	CAN2IDAR3	Write:								
\$01D4 -	CAN2IDMR0 -	Read:	AM7	AM6	AM5	AM4	AM3	AM2	AM1	AM0
\$01D7	CAN2IDMR3	Write:								

\$01C0 - \$01FF

CAN2 (Freescale Scalable CAN - FSCAN)

Address	Name	Read:	Bit 7	Bit 6	Bit 5	Bit 4	Bit 3	Bit 2	Bit 1	Bit 0
\$01D8 -	CAN2IDAR4 -	Read:	AC7	AC6	AC5	AC4	AC3	AC2	AC1	AC0
\$01DB	CAN2IDAR7	Write:								
\$01DC -	CAN2IDMR4 -	Read:	AM7	AM6	AM5	AM4	AM3	AM2	AM1	AM0
\$01DF	CAN2IDMR7	Write:								
\$01E0 -	CAN2RXFG	Read:	FOREGROUND RECEIVE BUFFER see Table 1-2							
\$01EF		Write:								
\$01F0 -	CAN2TXFG	Read:	FOREGROUND TRANSMIT BUFFER see Table 1-2							
\$01FF		Write:								

\$0200 - \$023F

CAN3 (Freescale Scalable CAN - FSCAN)

Address	Name	Read:	Bit 7	Bit 6	Bit 5	Bit 4	Bit 3	Bit 2	Bit 1	Bit 0
\$0200	CAN3CTL0	Read:	RXFRM	RXACT	CSWAI	SYNCH	TIME	WUPE	SLPRQ	INITRQ
		Write:								
\$0201	CAN3CTL1	Read:	CANE	CLKSRC	LOOPB	LISTEN	0	WUPM	SLPAK	INITAK
		Write:								
\$0202	CAN3BTR0	Read:	SJW1	SJW0	BRP5	BRP4	BRP3	BRP2	BRP1	BRP0
		Write:								
\$0203	CAN3BTR1	Read:	SAMP	TSEG22	TSEG21	TSEG20	TSEG13	TSEG12	TSEG11	TSEG10
		Write:								
\$0204	CAN3RFLG	Read:	WUPIF	CSCIF	RSTAT1	RSTAT0	TSTAT1	TSTAT0	OVRIF	RXF
		Write:								
\$0205	CAN3RIER	Read:	WUPIE	CSCIE	RSTATE1	RSTATE0	TSTATE1	TSTATE0	OVRIE	RXFIE
		Write:								
\$0206	CAN3TFLG	Read:	0	0	0	0	0	TXE2	TXE1	TXE0
		Write:								
\$0207	CAN3TIER	Read:	0	0	0	0	0	TXEIE2	TXEIE1	TXEIE0
		Write:								
\$0208	CAN3TARQ	Read:	0	0	0	0	0	ABTRQ2	ABTRQ1	ABTRQ0
		Write:								
\$0209	CAN3TAAK	Read:	0	0	0	0	0	ABTAK2	ABTAK1	ABTAK0
		Write:								
\$020A	CAN3TBSEL	Read:	0	0	0	0	0	TX2	TX1	TX0
		Write:								
\$020B	CAN3IDAC	Read:	0	0	IDAM1	IDAM0	0	IDHIT2	IDHIT1	IDHIT0
		Write:								
\$020C -	Reserved	Read:	0	0	0	0	0	0	0	0
\$020D		Write:								
\$020E	CAN3RXERR	Read:	RXERR7	RXERR6	RXERR5	RXERR4	RXERR3	RXERR2	RXERR1	RXERR0
		Write:								
\$020F	CAN3TXERR	Read:	TXERR7	TXERR6	TXERR5	TXERR4	TXERR3	TXERR2	TXERR1	TXERR0
		Write:								
\$0210 -	CAN3IDAR0 -	Read:	AC7	AC6	AC5	AC4	AC3	AC2	AC1	AC0
\$0213	CAN3IDAR3	Write:								
\$0214 -	CAN3IDMR0 -	Read:	AM7	AM6	AM5	AM4	AM3	AM2	AM1	AM0
\$0217	CAN3IDMR3	Write:								
\$0218 -	CAN3IDAR4 -	Read:	AC7	AC6	AC5	AC4	AC3	AC2	AC1	AC0
\$021B	CAN3IDAR7	Write:								

\$0200 - \$023F

CAN3 (Freescale Scalable CAN - FSCAN)

Address	Name	Read:	Bit 7	Bit 6	Bit 5	Bit 4	Bit 3	Bit 2	Bit 1	Bit 0
\$021C -	CAN3IDMR4 -	Read:	AM7	AM6	AM5	AM4	AM3	AM2	AM1	AM0
\$021F	CAN3IDMR7	Write:								
\$0220 -	CAN3RXFG	Read:	FOREGROUND RECEIVE BUFFER see Table 1-2							
\$022F		Write:								
\$0230 -	CAN3TXFG	Read:	FOREGROUND TRANSMIT BUFFER see Table 1-2							
\$023F		Write:								

\$0240 - \$027F

PIM (Port Integration Module PIM_9DP256)

Address	Name	Read:	Bit 7	Bit 6	Bit 5	Bit 4	Bit 3	Bit 2	Bit 1	Bit 0
\$0240	PTT	Read:	PTT7	PTT6	PTT5	PTT4	PTT3	PTT2	PTT1	PTT0
		Write:								
\$0241	PTIT	Read:	PTIT7	PTIT6	PTIT5	PTIT4	PTIT3	PTIT2	PTIT1	PTIT0
		Write:								
\$0242	DDRT	Read:	DDRT7	DDRT7	DDRT5	DDRT4	DDRT3	DDRT2	DDRT1	DDRT0
		Write:								
\$0243	RDRT	Read:	RDRT7	RDRT6	RDRT5	RDRT4	RDRT3	RDRT2	RDRT1	RDRT0
		Write:								
\$0244	PERT	Read:	PERT7	PERT6	PERT5	PERT4	PERT3	PERT2	PERT1	PERT0
		Write:								
\$0245	PPST	Read:	PPST7	PPST6	PPST5	PPST4	PPST3	PPST2	PPST1	PPST0
		Write:								
\$0246 -	Reserved	Read:	0	0	0	0	0	0	0	0
\$0247		Write:								
\$0248	PTS	Read:	PTS7	PTS6	PTS5	PTS4	PTS3	PTS2	PTS1	PTS0
		Write:								
\$0249	PTIS	Read:	PTIS7	PTIS6	PTIS5	PTIS4	PTIS3	PTIS2	PTIS1	PTIS0
		Write:								
\$024A	DDRS	Read:	DDRS7	DDRS7	DDRS5	DDRS4	DDRS3	DDRS2	DDRS1	DDRS0
		Write:								
\$024B	RDRS	Read:	RDRS7	RDRS6	RDRS5	RDRS4	RDRS3	RDRS2	RDRS1	RDRS0
		Write:								
\$024C	PERS	Read:	PERS7	PERS6	PERS5	PERS4	PERS3	PERS2	PERS1	PERS0
		Write:								
\$024D	PPSS	Read:	PPSS7	PPSS6	PPSS5	PPSS4	PPSS3	PPSS2	PPSS1	PPSS0
		Write:								
\$024E	WOMS	Read:	WOMS7	WOMS6	WOMS5	WOMS4	WOMS3	WOMS2	WOMS1	WOMS0
		Write:								
\$024F	Reserved	Read:	0	0	0	0	0	0	0	0
		Write:								
\$0250	PTM	Read:	PTM7	PTM6	PTM5	PTM4	PTM3	PTM2	PTM1	PTM0
		Write:								
\$0251	PTIM	Read:	PTIM7	PTIM6	PTIM5	PTIM4	PTIM3	PTIM2	PTIM1	PTIM0
		Write:								
\$0252	DDRM	Read:	DDRM7	DDRM7	DDRM5	DDRM4	DDRM3	DDRM2	DDRM1	DDRM0
		Write:								
\$0253	RDRM	Read:	RDRM7	RDRM6	RDRM5	RDRM4	RDRM3	RDRM2	RDRM1	RDRM0
		Write:								

\$0240 - \$027F**PIM (Port Integration Module PIM_9DP256)**

Address	Name		Bit 7	Bit 6	Bit 5	Bit 4	Bit 3	Bit 2	Bit 1	Bit 0
\$0254	PERM	Read:	PERM7	PERM6	PERM5	PERM4	PERM3	PERM2	PERM1	PERM0
		Write:								
\$0255	PPSM	Read:	PPSM7	PPSM6	PPSM5	PPSM4	PPSM3	PPSM2	PPSM1	PPSM0
		Write:								
\$0256	WOMM	Read:	WOMM7	WOMM6	WOMM5	WOMM4	WOMM3	WOMM2	WOMM1	WOMM0
		Write:								
\$0257	MODRR	Read:	0	MODRR6	MODRR5	MODRR4	MODRR3	MODRR2	MODRR1	MODRR0
		Write:								
\$0258	PTP	Read:	PTP7	PTP6	PTP5	PTP4	PTP3	PTP2	PTP1	PTP0
		Write:								
\$0259	PTIP	Read:	PTIP7	PTIP6	PTIP5	PTIP4	PTIP3	PTIP2	PTIP1	PTIP0
		Write:								
\$025A	DDRP	Read:	DDRP7	DDRP6	DDRP5	DDRP4	DDRP3	DDRP2	DDRP1	DDRP0
		Write:								
\$025B	RDRP	Read:	RDRP7	RDRP6	RDRP5	RDRP4	RDRP3	RDRP2	RDRP1	RDRP0
		Write:								
\$025C	PERP	Read:	PERP7	PERP6	PERP5	PERP4	PERP3	PERP2	PERP1	PERP0
		Write:								
\$025D	PPSP	Read:	PPSP7	PPSP6	PPSP5	PPSP4	PPSP3	PPSP2	PPSP1	PPSP0
		Write:								
\$025E	PIEP	Read:	PIEP7	PIEP6	PIEP5	PIEP4	PIEP3	PIEP2	PIEP1	PIEP0
		Write:								
\$025F	PIFP	Read:	PIFP7	PIFP6	PIFP5	PIFP4	PIFP3	PIFP2	PIFP1	PIFP0
		Write:								
\$0260	PTH	Read:	PTH7	PTH6	PTH5	PTH4	PTH3	PTH2	PTH1	PTH0
		Write:								
\$0261	PTIH	Read:	PTIH7	PTIH6	PTIH5	PTIH4	PTIH3	PTIH2	PTIH1	PTIH0
		Write:								
\$0262	DDRH	Read:	DDRH7	DDRH6	DDRH5	DDRH4	DDRH3	DDRH2	DDRH1	DDRH0
		Write:								
\$0263	RDRH	Read:	RDRH7	RDRH6	RDRH5	RDRH4	RDRH3	RDRH2	RDRH1	RDRH0
		Write:								
\$0264	PERH	Read:	PERH7	PERH6	PERH5	PERH4	PERH3	PERH2	PERH1	PERH0
		Write:								
\$0265	PPSH	Read:	PPSH7	PPSH6	PPSH5	PPSH4	PPSH3	PPSH2	PPSH1	PPSH0
		Write:								
\$0266	PIEH	Read:	PIEH7	PIEH6	PIEH5	PIEH4	PIEH3	PIEH2	PIEH1	PIEH0
		Write:								
\$0267	PIFH	Read:	PIFH7	PIFH6	PIFH5	PIFH4	PIFH3	PIFH2	PIFH1	PIFH0
		Write:								
\$0268	PTJ	Read:	PTJ7	PTJ6	0	0	0	0	PTJ1	PTJ0
		Write:								
\$0269	PTIJ	Read:	PTIJ7	PTIJ6	0	0	0	0	PTIJ1	PTIJ0
		Write:								
\$026A	DDRJ	Read:	DDRJ7	DDRJ6	0	0	0	0	DDRJ1	DDRJ0
		Write:								
\$026B	RDRJ	Read:	RDRJ7	RDRJ6	0	0	0	0	RDRJ1	RDRJ0
		Write:								
\$026C	PERJ	Read:	PERJ7	PERJ6	0	0	0	0	PERJ1	PERJ0
		Write:								

\$0240 - \$027F

PIM (Port Integration Module PIM_9DP256)

Address	Name		Bit 7	Bit 6	Bit 5	Bit 4	Bit 3	Bit 2	Bit 1	Bit 0
\$026D	PPSJ	Read:	PPSJ7	PPSJ6	0	0	0	0	PPSJ1	PPSJ0
		Write:								
\$026E	PIEJ	Read:	PIEJ7	PIEJ6	0	0	0	0	PIEJ1	PIEJ0
		Write:								
\$026F	PIFJ	Read:	PIFJ7	PIFJ6	0	0	0	0	PIFJ1	PIFJ0
		Write:								
\$0270 - \$027F	Reserved	Read:								

\$0280 - \$02BF

CAN4 (Freescale Scalable CAN - FSCAN)

Address	Name		Bit 7	Bit 6	Bit 5	Bit 4	Bit 3	Bit 2	Bit 1	Bit 0
\$0280	CAN4CTL0	Read:	RXFRM	RXACT	CSWAI	SYNCH	TIME	WUPE	SLPRQ	INITRQ
		Write:								
\$0281	CAN4CTL1	Read:	CANE	CLKSRC	LOOPB	LISTEN	0	WUPM	SLPAK	INITAK
		Write:								
\$0282	CAN4BTR0	Read:	SJW1	SJW0	BRP5	BRP4	BRP3	BRP2	BRP1	BRP0
		Write:								
\$0283	CAN4BTR1	Read:	SAMP	TSEG22	TSEG21	TSEG20	TSEG13	TSEG12	TSEG11	TSEG10
		Write:								
\$0284	CAN4RFLG	Read:	WUPIF	CSCIF	RSTAT1	RSTAT0	TSTAT1	TSTAT0	OVRIF	RXF
		Write:								
\$0285	CAN4RIER	Read:	WUPIE	CSCIE	RSTATE1	RSTATE0	TSTATE1	TSTATE0	OVRIE	RXFIE
		Write:								
\$0286	CAN4TFLG	Read:	0	0	0	0	0	TXE2	TXE1	TXE0
		Write:								
\$0287	CAN4TIER	Read:	0	0	0	0	0	TXEIE2	TXEIE1	TXEIE0
		Write:								
\$0288	CAN4TARQ	Read:	0	0	0	0	0	ABTRQ2	ABTRQ1	ABTRQ0
		Write:								
\$0289	CAN4TAAK	Read:	0	0	0	0	0	ABTAK2	ABTAK1	ABTAK0
		Write:								
\$028A	CAN4TBSEL	Read:	0	0	0	0	0	TX2	TX1	TX0
		Write:								
\$028B	CAN4IDAC	Read:	0	0	IDAM1	IDAM0	0	IDHIT2	IDHIT1	IDHIT0
		Write:								
\$028C - \$028D	Reserved	Read:	0	0	0	0	0	0	0	0
		Write:								
\$028E	CAN4RXERR	Read:	RXERR7	RXERR6	RXERR5	RXERR4	RXERR3	RXERR2	RXERR1	RXERR0
		Write:								
\$028F	CAN4TXERR	Read:	TXERR7	TXERR6	TXERR5	TXERR4	TXERR3	TXERR2	TXERR1	TXERR0
		Write:								
\$0290 - \$0293	CAN4IDAR0 - CAN4IDAR3	Read:	AC7	AC6	AC5	AC4	AC3	AC2	AC1	AC0
		Write:								
\$0294 - \$0297	CAN4IDMR0 - CAN4IDMR3	Read:	AM7	AM6	AM5	AM4	AM3	AM2	AM1	AM0
		Write:								
\$0298 - \$029B	CAN4IDAR4 - CAN4IDAR7	Read:	AC7	AC6	AC5	AC4	AC3	AC2	AC1	AC0
		Write:								

\$0280 - \$02BF**CAN4 (Freescale Scalable CAN - FSCAN)**

Address	Name		Bit 7	Bit 6	Bit 5	Bit 4	Bit 3	Bit 2	Bit 1	Bit 0
\$029C -	CAN4IDMR4 -	Read:	AM7	AM6	AM5	AM4	AM3	AM2	AM1	AM0
\$029F	CAN4IDMR7	Write:								
\$02A0 -	CAN4RXFG	Read:	FOREGROUND RECEIVE BUFFER see Table 1-2							
\$02AF		Write:								
\$02B0 -	CAN4TXFG	Read:	FOREGROUND TRANSMIT BUFFER see Table 1-2							
\$02BF		Write:								

\$02C0 - \$03FF**Reserved**

Address	Name		Bit 7	Bit 6	Bit 5	Bit 4	Bit 3	Bit 2	Bit 1	Bit 0
\$02C0 -	Reserved	Read:	0	0	0	0	0	0	0	0
\$03FF		Write:								

1.6 Part ID Assignments

The part ID is located in two 8-bit registers PARTIDH and PARTIDL (addresses \$001A and \$001B after reset). The read-only value is a unique part ID for each revision of the chip. **Table 1-3** shows the assigned part ID number.

Table 1-3 Assigned Part ID Numbers

Device	Mask Set Number	Part ID ¹
MC9S12DP512	0L00M	\$0400
MC9S12DP512	1L00M	\$0401
MC9S12DP512	2L00M	\$0402
MC9S12DP512	3L00M	\$0403
MC9S12DP512	4L00M	\$0404

NOTES:

1. The coding is as follows:

Bit 15 - 12: Major family identifier

Bit 11 - 8: Minor family identifier

Bit 7 - 4: Major mask set revision number including FAB transfers

Bit 3 - 0: Minor - non full - mask set revision

1.7 Memory Size Assignments

The device memory sizes are located in two 8-bit registers MEMSIZ0 and MEMSIZ1 (addresses \$001C and \$001D after reset). **Table 1-4** shows the read-only values of these registers. Refer to HCS12 Module Mapping Control (MMC) Block Guide for further details.

Table 1-4 Memory size registers

Register name	Value
MEMSIZ0	\$26
MEMSIZ1	\$82



Section 2 Signal Description

This section describes signals that connect off-chip. It includes a pinout diagram, a table of signal properties, and detailed discussion of signals. It is built from the signal description sections of the Block Guides of the individual IP blocks on the device.

2.1 Device Pinout

The MC9S12DP512 is available in a 112-pin low profile quad flat pack (LQFP). Most pins perform two or more functions, as described in the Signal Descriptions. **Figure 2-1** shows the pin assignments.

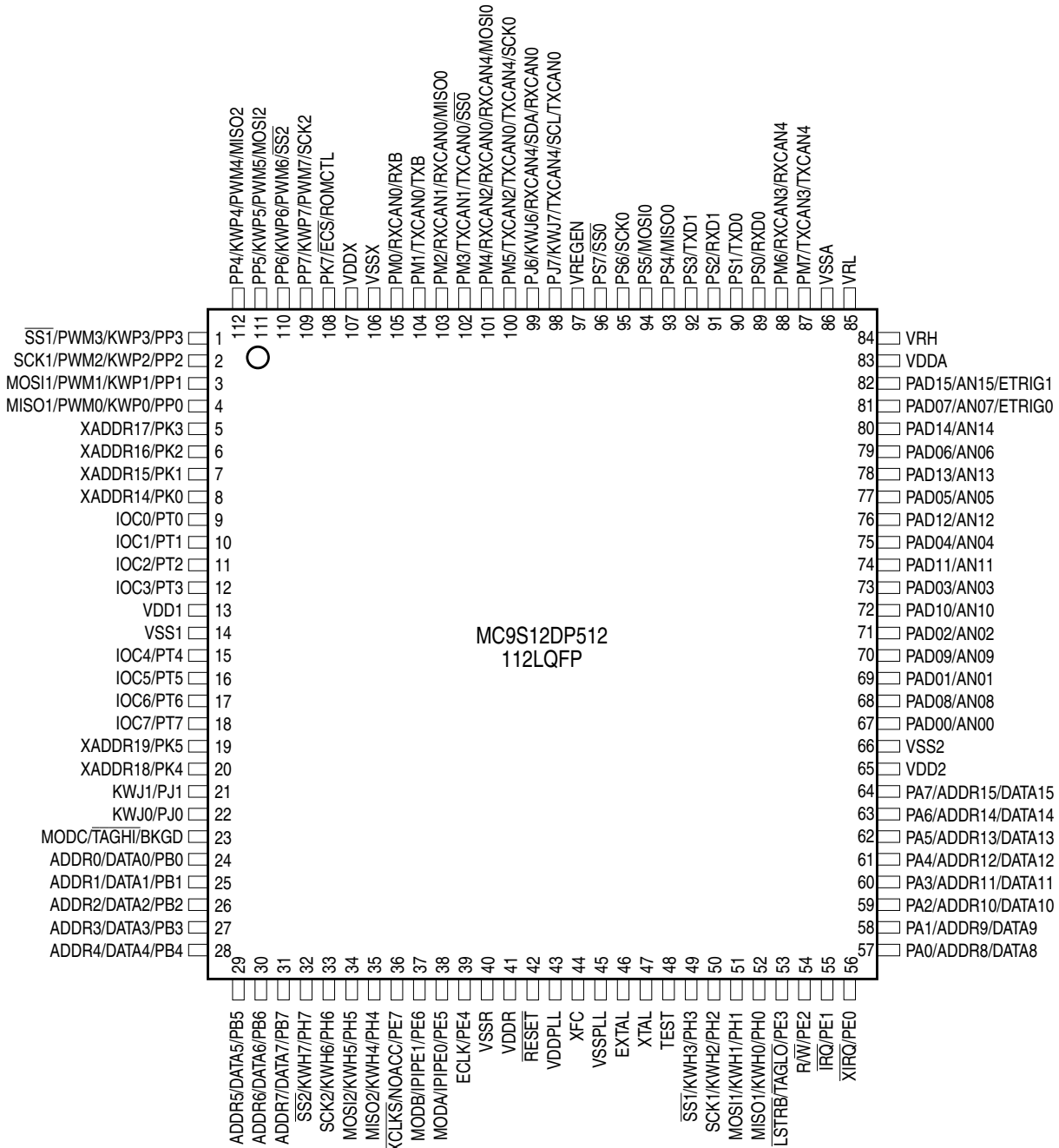

Figure 2-1 Pin Assignments in 112-pin LQFP

2.2 Signal Properties Summary

Table 2-1 summarizes the pin functionality.

Table 2-1 Signal Properties

Pin Name Funct. 1	Pin Name Funct. 2	Pin Name Funct. 3	Pin Name Funct. 4	Pin Name Funct. 5	Power Supply	Internal Pull Resistor		Description	
						CTRL	Reset State		
EXTAL	—	—	—	—	VDDPLL	None	None	Oscillator Pins	
XTAL	—	—	—	—				External Reset	
RESET	—	—	—	—				Test Input	
TEST	—	—	—	—				NA	Voltage Regulator Enable Input
VREGEN	—	—	—	—				VDDX	PLL Loop Filter
XFC	—	—	—	—				VDDPLL	
BKGD	TAGHI	MODC	—	—	VDDR	Always Up	Up	Background Debug, Tag High, Mode Input	
PAD15	AN15	ETRIG1	—	—	VDDA	None	None	Port AD Input, Analog Input AN7 of ATD1, External Trigger Input of ATD1	
PAD[14:8]	AN[14:08]	—	—	—				Port AD Inputs, Analog Inputs AN[6:0] of ATD1	
PAD07	AN07	ETRIG0	—	—				Port AD Input, Analog Input AN7 of ATD0, External Trigger Input of ATD0	
PAD[06:00]	AN[06:00]	—	—	—				Port AD Inputs, Analog Inputs AN[6:0] of ATD0	
PA[7:0]	ADDR[15:8]/ DATA[15:8]	—	—	—	VDDR	PUCR/ PUPAE	Disabled	Port A I/O, Multiplexed Address/Data	
PB[7:0]	ADDR[7:0]/ DATA[7:0]	—	—	—				PUCR/ PUPBE	Port B I/O, Multiplexed Address/Data
PE7	NOACC	XCLKS	—	—		PUCR/ PUPEE	Up	Port E I/O, Access, Clock Select	
PE6	IPIPE1	MODB	—	—		While RESET pin is low: Down		Port E I/O, Pipe Status, Mode Input	
PE5	IPIPE0	MODA	—	—		While RESET pin is low: Down		Port E I/O, Pipe Status, Mode Input	
PE4	ECLK	—	—	—		PUCR/ PUPEE	Up	Port E I/O, Bus Clock Output	
PE3	LSTRB	TAGLO	—	—				Port E I/O, Byte Strobe, Tag Low	
PE2	R/W	—	—	—				Port E I/O, R/W in expanded modes	
PE1	IRQ	—	—	—				Port E Input, Maskable Interrupt	
PE0	XIRQ	—	—	—				Port E Input, Non Maskable Interrupt	

MC9S12DP512 Device Guide V01.25

Pin Name Funct. 1	Pin Name Funct. 2	Pin Name Funct. 3	Pin Name Funct. 4	Pin Name Funct. 5	Power Supply	Internal Pull Resistor		Description
						CTRL	Reset State	
PH7	KWH7	SS2	—	—	VDDR	PERH/ PPSH	Disabled	Port H I/O, Interrupt, SS of SPI2
PH6	KWH6	SCK2	—	—				Port H I/O, Interrupt, SCK of SPI2
PH5	KWH5	MOSI2	—	—				Port H I/O, Interrupt, MOSI of SPI2
PH4	KWH4	MISO2	—	—				Port H I/O, Interrupt, MISO of SPI2
PH3	KWH3	SS1	—	—				Port H I/O, Interrupt, SS of SPI1
PH2	KWH2	SCK1	—	—				Port H I/O, Interrupt, SCK of SPI1
PH1	KWH1	MOSI1	—	—				Port H I/O, Interrupt, MOSI of SPI1
PH0	KWH0	MISO1	—	—				Port H I/O, Interrupt, MISO of SPI1
PJ7	KWJ7	TXCAN4	SCL	TXCAN0	VDDX	PERJ/ PPSJ	Up	Port J I/O, Interrupt, TX of CAN4, SCL of IIC, TX of CAN0
PJ6	KWJ6	RXCAN4	SDA	RXCAN0				Port J I/O, Interrupt, RX of CAN4, SDA of IIC, RX of CAN0
PJ[1:0]	KWJ[1:0]	—	—	—				Port J I/O, Interrupts
PK7	ECS	ROMCTL	—	—	VDDX	PUCR/ PUPKE	Up	Port K I/O, Emulation Chip Select, ROM Control
PK[5:0]	XADDR [19:14]	—	—	—				Port K I/O, Extended Addresses
PM7	TXCAN3	TXCAN4	—	—	VDDX	PERM/ PPSM	Disabled	Port M I/O, TX of CAN3, TX of CAN4
PM6	RXCAN3	RXCAN4	—	—				Port M I/O, RX of CAN3, RX of CAN4
PM5	TXCAN2	TXCAN0	TXCAN4	SCK0				Port M I/O, TX of CAN2, CAN0, CAN4, SCK of SPI0
PM4	RXCAN2	RXCAN0	RXCAN4	MOSI0				Port M I/O, RX of CAN2, CAN0, CAN4, MOSI of SPI0
PM3	TXCAN1	TXCAN0	—	SS0				Port M I/O, TX of CAN1, CAN0, SS of SPI0
PM2	RXCAN1	RXCAN0	—	MISO0				Port M I/O, RX of CAN1, CAN0, MISO of SPI0
PM1	TXCAN0	TXB	—	—				Port M I/O, TX of CAN0, RX of BDLC
PM0	RXCAN0	RXB	—	—				Port M I/O, RX of CAN0, RX of BDLC
PP7	KWP7	PWM7	SCK2	—	VDDX	PERP/ PPSP	Disabled	Port P I/O, Interrupt, Channel 7 of PWM, SCK of SPI2
PP6	KWP6	PWM6	SS2	—				Port P I/O, Interrupt, Channel 6 of PWM, SS of SPI2
PP5	KWP5	PWM5	MOSI2	—				Port P I/O, Interrupt, Channel 5 of PWM, MOSI of SPI2
PP4	KWP4	PWM4	MISO2	—				Port P I/O, Interrupt, Channel 4 of PWM, MISO2 of SPI2
PP3	KWP3	PWM3	SS1	—				Port P I/O, Interrupt, Channel 3 of PWM, SS of SPI1
PP2	KWP2	PWM2	SCK1	—				Port P I/O, Interrupt, Channel 2 of PWM, SCK of SPI1
PP1	KWP1	PWM1	MOSI1	—				Port P I/O, Interrupt, Channel 1 of PWM, MOSI of SPI1
PP0	KWP0	PWM0	MISO1	—				Port P I/O, Interrupt, Channel 0 of PWM, MISO2 of SPI1

Pin Name Funct. 1	Pin Name Funct. 2	Pin Name Funct. 3	Pin Name Funct. 4	Pin Name Funct. 5	Power Supply	Internal Pull Resistor		Description
						CTRL	Reset State	
PS7	SS0	—	—	—	VDDX	PERS/ PPSS	Up	Port S I/O, \overline{SS} of SPI0
PS6	SCK0	—	—	—				Port S I/O, SCK of SPI0
PS5	MOSI0	—	—	—				Port S I/O, MOSI of SPI0
PS4	MISO0	—	—	—				Port S I/O, MISO of SPI0
PS3	TXD1	—	—	—				Port S I/O, TXD of SCI1
PS2	RXD1	—	—	—				Port S I/O, RXD of SCI1
PS1	TXD0	—	—	—				Port S I/O, TXD of SCI0
PS0	RXD0	—	—	—				Port S I/O, RXD of SCI0
PT[7:0]	IOC[7:0]	—	—	—	VDDX	PERT/ PPST	Disabled	Port T I/O, Timer channels

2.3 Detailed Signal Descriptions

2.3.1 EXTAL, XTAL — Oscillator Pins

EXTAL and XTAL are the crystal driver and external clock pins. On reset all the device clocks are derived from the EXTAL input frequency. XTAL is the crystal output.

2.3.2 \overline{RESET} — External Reset Pin

An active low bidirectional control signal, it acts as an input to initialize the MCU to a known start-up state, and an output when an internal MCU function causes a reset.

2.3.3 TEST — Test Pin

This input only pin is reserved for test.

NOTE: *The TEST pin must be tied to VSS in all applications.*

2.3.4 VREGEN — Voltage Regulator Enable Pin

This input only pin enables or disables the on-chip voltage regulator.

2.3.5 XFC — PLL Loop Filter Pin

PLL loop filter. Please ask your Freescale representative for the interactive application note to compute PLL loop filter elements. Any current leakage on this pin must be avoided.

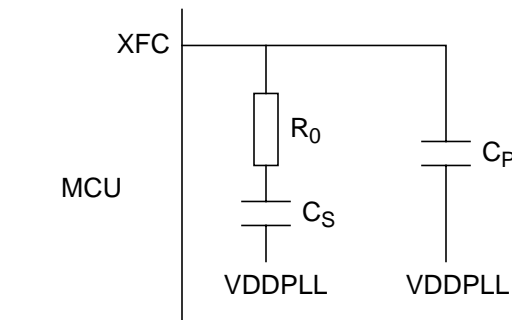

Figure 2-2 PLL Loop Filter Connections

2.3.6 BKGD / $\overline{\text{TAGHI}}$ / MODC — Background Debug, Tag High, and Mode Pin

The BKGD/ $\overline{\text{TAGHI}}$ /MODC pin is used as a pseudo-open-drain pin for the background debug communication. In MCU expanded modes of operation when instruction tagging is on, an input low on this pin during the falling edge of E-clock tags the high half of the instruction word being read into the instruction queue. It is used as a MCU operating mode select pin during reset. The state of this pin is latched to the MODC bit at the rising edge of $\overline{\text{RESET}}$. This pin has a permanently enabled pull-up device.

2.3.7 PAD15 / AN15 / ETRIG1 — Port AD Input Pin of ATD1

PAD15 is a general purpose input pin and analog input AN7 of the analog to digital converter ATD1. It can act as an external trigger input for the ATD1.

2.3.8 PAD[14:08] / AN[14:08] — Port AD Input Pins of ATD1

PAD14 - PAD08 are general purpose input pins and analog inputs AN[6:0] of the analog to digital converter ATD1.

2.3.9 PAD7 / AN07 / ETRIG0 — Port AD Input Pin of ATD0

PAD7 is a general purpose input pin and analog input AN7 of the analog to digital converter ATD0. It can act as an external trigger input for the ATD0.

2.3.10 PAD[06:00] / AN[06:00] — Port AD Input Pins of ATD0

PAD06 - PAD00 are general purpose input pins and analog inputs AN[6:0] of the analog to digital converter ATD0.

2.3.11 PA[7:0] / ADDR[15:8] / DATA[15:8] — Port A I/O Pins

PA7-PA0 are general purpose input or output pins. In MCU expanded modes of operation, these pins are used for the multiplexed external address and data bus.

2.3.12 PB[7:0] / ADDR[7:0] / DATA[7:0] — Port B I/O Pins

PB7-PB0 are general purpose input or output pins. In MCU expanded modes of operation, these pins are used for the multiplexed external address and data bus.

2.3.13 PE7 / NOACC / \overline{XCLKS} — Port E I/O Pin 7

PE7 is a general purpose input or output pin. During MCU expanded modes of operation, the NOACC signal, when enabled, is used to indicate that the current bus cycle is an unused or “free” cycle. This signal will assert when the CPU is not using the bus.

The \overline{XCLKS} is an input signal which controls whether a crystal in combination with the internal Colpitts (low power) oscillator is used or whether Pierce oscillator/external clock circuitry is used. The state of this pin is latched at the rising edge of \overline{RESET} . If the input is a logic low the EXTAL pin is configured for an external clock drive or a Pierce Oscillator. If input is a logic high a Colpitts oscillator circuit is configured on EXTAL and XTAL. Since this pin is an input with a pull-up device during reset, if the pin is left floating, the default configuration is a Colpitts oscillator circuit on EXTAL and XTAL.

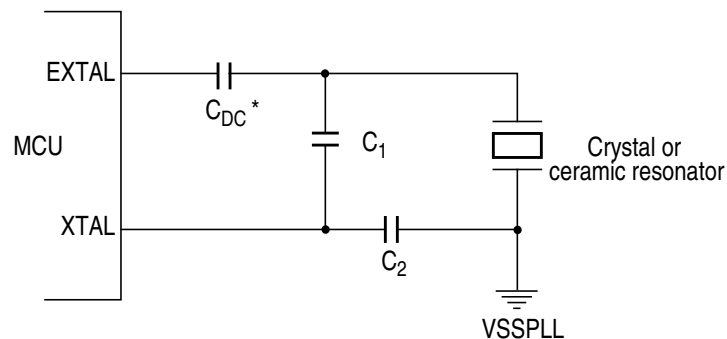

* Due to the nature of a translated ground Colpitts oscillator a DC voltage bias is applied to the crystal

Please contact the crystal manufacturer for crystal DC bias conditions and recommended capacitor value C_{DC} .

Figure 2-3 Colpitts Oscillator Connections (PE7=1)

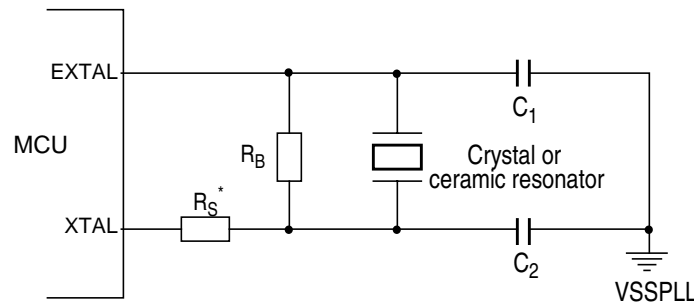

* R_S can be zero (shorted) when used with higher frequency crystals. Refer to manufacturer's data.

Figure 2-4 Pierce Oscillator Connections (PE7=0)

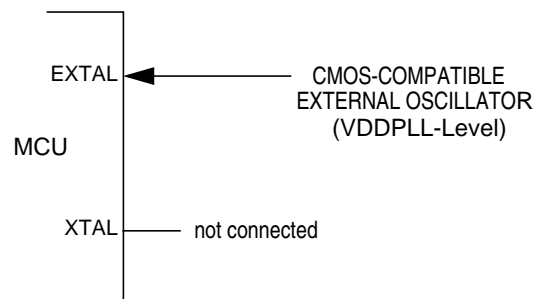

Figure 2-5 External Clock Connections (PE7=0)

2.3.14 PE6 / MODB / IPIPE1 — Port E I/O Pin 6

PE6 is a general purpose input or output pin. It is used as a MCU operating mode select pin during reset. The state of this pin is latched to the MODB bit at the rising edge of $\overline{\text{RESET}}$. This pin is shared with the instruction queue tracking signal IPIPE1. This pin is an input with a pull-down device which is only active when $\overline{\text{RESET}}$ is low.

2.3.15 PE5 / MODA / IPIPE0 — Port E I/O Pin 5

PE5 is a general purpose input or output pin. It is used as a MCU operating mode select pin during reset. The state of this pin is latched to the MODA bit at the rising edge of $\overline{\text{RESET}}$. This pin is shared with the instruction queue tracking signal IPIPE0. This pin is an input with a pull-down device which is only active when $\overline{\text{RESET}}$ is low.

2.3.16 PE4 / ECLK — Port E I/O Pin 4

PE4 is a general purpose input or output pin. It can be configured to drive the internal bus clock ECLK. ECLK can be used as a timing reference.

2.3.17 PE3 / $\overline{\text{LSTRB}}$ / $\overline{\text{TAGLO}}$ — Port E I/O Pin 3

PE3 is a general purpose input or output pin. In MCU expanded modes of operation, $\overline{\text{LSTRB}}$ can be used for the low-byte strobe function to indicate the type of bus access and when instruction tagging is on, $\overline{\text{TAGLO}}$ is used to tag the low half of the instruction word being read into the instruction queue.

2.3.18 PE2 / $\overline{\text{R/W}}$ — Port E I/O Pin 2

PE2 is a general purpose input or output pin. In MCU expanded modes of operations, this pin drives the read/write output signal for the external bus. It indicates the direction of data on the external bus.

2.3.19 PE1 / $\overline{\text{IRQ}}$ — Port E Input Pin 1

PE1 is a general purpose input pin and the maskable interrupt request input that provides a means of applying asynchronous interrupt requests. This will wake up the MCU from STOP or WAIT mode.

2.3.20 PE0 / $\overline{\text{XIRQ}}$ — Port E Input Pin 0

PE0 is a general purpose input pin and the non-maskable interrupt request input that provides a means of applying asynchronous interrupt requests. This will wake up the MCU from STOP or WAIT mode.

2.3.21 PH7 / KWH7 / $\overline{\text{SS2}}$ — Port H I/O Pin 7

PH7 is a general purpose input or output pin. It can be configured to generate an interrupt causing the MCU to exit STOP or WAIT mode. It can be configured as slave select pin $\overline{\text{SS}}$ of the Serial Peripheral Interface 2 (SPI2).

2.3.22 PH6 / KWH6 / SCK2 — Port H I/O Pin 6

PH6 is a general purpose input or output pin. It can be configured to generate an interrupt causing the MCU to exit STOP or WAIT mode. It can be configured as serial clock pin SCK of the Serial Peripheral Interface 2 (SPI2).

2.3.23 PH5 / KWH5 / MOSI2 — Port H I/O Pin 5

PH5 is a general purpose input or output pin. It can be configured to generate an interrupt causing the MCU to exit STOP or WAIT mode. It can be configured as master output (during master mode) or slave input pin (during slave mode) MOSI of the Serial Peripheral Interface 2 (SPI2).

2.3.24 PH4 / KWH4 / MISO2 — Port H I/O Pin 2

PH4 is a general purpose input or output pin. It can be configured to generate an interrupt causing the MCU to exit STOP or WAIT mode. It can be configured as master input (during master mode) or slave output (during slave mode) pin MISO of the Serial Peripheral Interface 2 (SPI2).

2.3.25 PH3 / KWH3 / $\overline{SS1}$ — Port H I/O Pin 3

PH3 is a general purpose input or output pin. It can be configured to generate an interrupt causing the MCU to exit STOP or WAIT mode. It can be configured as slave select pin \overline{SS} of the Serial Peripheral Interface 1 (SPI1).

2.3.26 PH2 / KWH2 / SCK1 — Port H I/O Pin 2

PH2 is a general purpose input or output pin. It can be configured to generate an interrupt causing the MCU to exit STOP or WAIT mode. It can be configured as serial clock pin SCK of the Serial Peripheral Interface 1 (SPI1).

2.3.27 PH1 / KWH1 / MOSI1 — Port H I/O Pin 1

PH1 is a general purpose input or output pin. It can be configured to generate an interrupt causing the MCU to exit STOP or WAIT mode. It can be configured as master output (during master mode) or slave input pin (during slave mode) MOSI of the Serial Peripheral Interface 1 (SPI1).

2.3.28 PH0 / KWH0 / MISO1 — Port H I/O Pin 0

PH0 is a general purpose input or output pin. It can be configured to generate an interrupt causing the MCU to exit STOP or WAIT mode. It can be configured as master input (during master mode) or slave output (during slave mode) pin MISO of the Serial Peripheral Interface 1 (SPI1).

2.3.29 PJ7 / KWJ7 / TXCAN4 / SCL / TXCAN0 — PORT J I/O Pin 7

PJ7 is a general purpose input or output pin. It can be configured to generate an interrupt causing the MCU to exit STOP or WAIT mode. It can be configured as the transmit pin TXCAN for the Freescale Scalable Controller Area Network controller 0 or 4 (CAN0 or CAN4) or the serial clock pin SCL of the IIC module.

2.3.30 PJ6 / KWJ6 / RXCAN4 / SDA / RXCAN0 — PORT J I/O Pin 6

PJ6 is a general purpose input or output pin. It can be configured to generate an interrupt causing the MCU to exit STOP or WAIT mode. It can be configured as the receive pin RXCAN for the Freescale Scalable Controller Area Network controller 0 or 4 (CAN0 or CAN4) or the serial data pin SDA of the IIC module.

2.3.31 PJ[1:0] / KWJ[1:0] — Port J I/O Pins [1:0]

PJ1 and PJ0 are general purpose input or output pins. They can be configured to generate an interrupt causing the MCU to exit STOP or WAIT mode.

2.3.32 PK7 / \overline{ECS} / ROMCTL — Port K I/O Pin 7

PK7 is a general purpose input or output pin. During MCU expanded modes of operation, this pin is used as the emulation chip select output (\overline{ECS}). During MCU normal expanded modes of operation, this pin is

used to enable the Flash EEPROM memory in the memory map (ROMCTL). At the rising edge of $\overline{\text{RESET}}$, the state of this pin is latched to the ROMON bit.

2.3.33 PK[5:0] / XADDR[19:14] — Port K I/O Pins [5:0]

PK5-PK0 are general purpose input or output pins. In MCU expanded modes of operation, these pins provide the expanded address XADDR[19:14] for the external bus.

2.3.34 PM7 / TXCAN3 / TXCAN4 — Port M I/O Pin 7

PM7 is a general purpose input or output pin. It can be configured as the transmit pin TXCAN of the Freescale Scalable Controller Area Network controllers 3 or 4 (CAN3 or CAN4).

2.3.35 PM6 / RXCAN3 / RXCAN4 — Port M I/O Pin 6

PM6 is a general purpose input or output pin. It can be configured as the receive pin RXCAN of the Freescale Scalable Controller Area Network controllers 3 or 4 (CAN3 or CAN4).

2.3.36 PM5 / TXCAN2 / TXCAN0 / TXCAN4 / SCK0 — Port M I/O Pin 5

PM5 is a general purpose input or output pin. It can be configured as the transmit pin TXCAN of the Freescale Scalable Controller Area Network controllers 2, 0 or 4 (CAN2, CAN0 or CAN4). It can be configured as the serial clock pin SCK of the Serial Peripheral Interface 0 (SPI0).

2.3.37 PM4 / RXCAN2 / RXCAN0 / RXCAN4/ MOSI0 — Port M I/O Pin 4

PM4 is a general purpose input or output pin. It can be configured as the receive pin RXCAN of the Freescale Scalable Controller Area Network controllers 2, 0 or 4 (CAN2, CAN0 or CAN4). It can be configured as the master output (during master mode) or slave input pin (during slave mode) MOSI for the Serial Peripheral Interface 0 (SPI0).

2.3.38 PM3 / TXCAN1 / TXCAN0 / $\overline{\text{SS0}}$ — Port M I/O Pin 3

PM3 is a general purpose input or output pin. It can be configured as the transmit pin TXCAN of the Freescale Scalable Controller Area Network controllers 1 or 0 (CAN1 or CAN0). It can be configured as the slave select pin $\overline{\text{SS}}$ of the Serial Peripheral Interface 0 (SPI0).

2.3.39 PM2 / RXCAN1 / RXCAN0 / MISO0 — Port M I/O Pin 2

PM2 is a general purpose input or output pin. It can be configured as the receive pin RXCAN of the Freescale Scalable Controller Area Network controllers 1 or 0 (CAN1 or CAN0). It can be configured as the master input (during master mode) or slave output pin (during slave mode) MISO for the Serial Peripheral Interface 0 (SPI0).

2.3.40 PM1 / TXCAN0 / TXB — Port M I/O Pin 1

PM1 is a general purpose input or output pin. It can be configured as the transmit pin TXCAN of the Freescale Scalable Controller Area Network controller 0 (CAN0). It can be configured as the transmit pin TXB of the BDLC.

2.3.41 PM0 / RXCAN0 / RXB — Port M I/O Pin 0

PM0 is a general purpose input or output pin. It can be configured as the receive pin RXCAN of the Freescale Scalable Controller Area Network controller 0 (CAN0). It can be configured as the receive pin RXB of the BDLC.

2.3.42 PP7 / KWP7 / PWM7 / SCK2 — Port P I/O Pin 7

PP7 is a general purpose input or output pin. It can be configured to generate an interrupt causing the MCU to exit STOP or WAIT mode. It can be configured as Pulse Width Modulator (PWM) channel 7 output or an input for the PWM emergency shutdown. It can be configured as serial clock pin SCK of the Serial Peripheral Interface 2 (SPI2).

2.3.43 PP6 / KWP6 / PWM6 / $\overline{SS2}$ — Port P I/O Pin 6

PP6 is a general purpose input or output pin. It can be configured to generate an interrupt causing the MCU to exit STOP or WAIT mode. It can be configured as Pulse Width Modulator (PWM) channel 6 output. It can be configured as slave select pin \overline{SS} of the Serial Peripheral Interface 2 (SPI2).

2.3.44 PP5 / KWP5 / PWM5 / MOSI2 — Port P I/O Pin 5

PP5 is a general purpose input or output pin. It can be configured to generate an interrupt causing the MCU to exit STOP or WAIT mode. It can be configured as Pulse Width Modulator (PWM) channel 5 output. It can be configured as master output (during master mode) or slave input pin (during slave mode) MOSI of the Serial Peripheral Interface 2 (SPI2).

2.3.45 PP4 / KWP4 / PWM4 / MISO2 — Port P I/O Pin 4

PP4 is a general purpose input or output pin. It can be configured to generate an interrupt causing the MCU to exit STOP or WAIT mode. It can be configured as Pulse Width Modulator (PWM) channel 4 output. It can be configured as master input (during master mode) or slave output (during slave mode) pin MISO of the Serial Peripheral Interface 2 (SPI2).

2.3.46 PP3 / KWP3 / PWM3 / $\overline{SS1}$ — Port P I/O Pin 3

PP3 is a general purpose input or output pin. It can be configured to generate an interrupt causing the MCU to exit STOP or WAIT mode. It can be configured as Pulse Width Modulator (PWM) channel 3 output. It can be configured as slave select pin \overline{SS} of the Serial Peripheral Interface 1 (SPI1).

2.3.47 PP2 / KWP2 / PWM2 / SCK1 — Port P I/O Pin 2

PP2 is a general purpose input or output pin. It can be configured to generate an interrupt causing the MCU to exit STOP or WAIT mode. It can be configured as Pulse Width Modulator (PWM) channel 2 output. It can be configured as serial clock pin SCK of the Serial Peripheral Interface 1 (SPI1).

2.3.48 PP1 / KWP1 / PWM1 / MOSI1 — Port P I/O Pin 1

PP1 is a general purpose input or output pin. It can be configured to generate an interrupt causing the MCU to exit STOP or WAIT mode. It can be configured as Pulse Width Modulator (PWM) channel 1 output. It can be configured as master output (during master mode) or slave input pin (during slave mode) MOSI of the Serial Peripheral Interface 1 (SPI1).

2.3.49 PP0 / KWP0 / PWM0 / MISO1 — Port P I/O Pin 0

PP0 is a general purpose input or output pin. It can be configured to generate an interrupt causing the MCU to exit STOP or WAIT mode. It can be configured as Pulse Width Modulator (PWM) channel 0 output. It can be configured as master input (during master mode) or slave output (during slave mode) pin MISO of the Serial Peripheral Interface 1 (SPI1).

2.3.50 PS7 / $\overline{SS0}$ — Port S I/O Pin 7

PS6 is a general purpose input or output pin. It can be configured as the slave select pin \overline{SS} of the Serial Peripheral Interface 0 (SPI0).

2.3.51 PS6 / SCK0 — Port S I/O Pin 6

PS6 is a general purpose input or output pin. It can be configured as the serial clock pin SCK of the Serial Peripheral Interface 0 (SPI0).

2.3.52 PS5 / MOSI0 — Port S I/O Pin 5

PS5 is a general purpose input or output pin. It can be configured as master output (during master mode) or slave input pin (during slave mode) MOSI of the Serial Peripheral Interface 0 (SPI0).

2.3.53 PS4 / MISO0 — Port S I/O Pin 4

PS4 is a general purpose input or output pin. It can be configured as master input (during master mode) or slave output pin (during slave mode) MOSI of the Serial Peripheral Interface 0 (SPI0).

2.3.54 PS3 / TXD1 — Port S I/O Pin 3

PS3 is a general purpose input or output pin. It can be configured as the transmit pin TXD of Serial Communication Interface 1 (SCI1).

2.3.55 PS2 / RXD1 — Port S I/O Pin 2

PS2 is a general purpose input or output pin. It can be configured as the receive pin RXD of Serial Communication Interface 1 (SCI1).

2.3.56 PS1 / TXD0 — Port S I/O Pin 1

PS1 is a general purpose input or output pin. It can be configured as the transmit pin TXD of Serial Communication Interface 0 (SCI0).

2.3.57 PS0 / RXD0 — Port S I/O Pin 0

PS0 is a general purpose input or output pin. It can be configured as the receive pin RXD of Serial Communication Interface 0 (SCI0).

2.3.58 PT[7:0] / IOC[7:0] — Port T I/O Pins [7:0]

PT7-PT0 are general purpose input or output pins. They can be configured as input capture or output compare pins IOC7-IOC0 of the Enhanced Capture Timer (ECT).

2.4 Power Supply Pins

MC9S12DP512 power and ground pins are described below.

Table 2-2 MC9S12DP512 Power and Ground Connection Summary

Mnemonic	Pin Number	Nominal Voltage	Description
	112-pin QFP		
$V_{DD1,2}$	13, 65	2.5 V	Internal power and ground generated by internal regulator
$V_{SS1,2}$	14, 66	0V	
V_{DDR}	41	5.0 V	External power and ground, supply to pin drivers and internal voltage regulator.
V_{SSR}	40	0 V	
V_{DDX}	107	5.0 V	External power and ground, supply to pin drivers.
V_{SSX}	106	0 V	
V_{DDA}	83	5.0 V	Operating voltage and ground for the analog-to-digital converters and the reference for the internal voltage regulator, allows the supply voltage to the A/D to be bypassed independently.
V_{SSA}	86	0 V	
V_{RL}	85	0 V	Reference voltages for the analog-to-digital converter.
V_{RH}	84	5.0 V	
V_{DDPLL}	43	2.5 V	Provides operating voltage and ground for the Phased-Locked Loop. This allows the supply voltage to the PLL to be bypassed independently. Internal power and ground generated by internal regulator.
V_{SSPLL}	45	0 V	
VREGEN	97	5V	Internal Voltage Regulator enable/disable

NOTE: *All VSS pins must be connected together in the application.*

2.4.1 VDDX,VSSX — Power & Ground Pins for I/O Drivers

External power and ground for I/O drivers. Because fast signal transitions place high, short-duration current demands on the power supply, use bypass capacitors with high-frequency characteristics and place them as close to the MCU as possible. Bypass requirements depend on how heavily the MCU pins are loaded.

2.4.2 VDDR, VSSR — Power & Ground Pins for I/O Drivers & Internal Voltage Regulator

External power and ground for I/O drivers and input to the internal voltage regulator. Because fast signal transitions place high, short-duration current demands on the power supply, use bypass capacitors with high-frequency characteristics and place them as close to the MCU as possible. Bypass requirements depend on how heavily the MCU pins are loaded.

2.4.3 VDD1, VDD2, VSS1, VSS2 — Internal Logic Power Supply Pins

Power is supplied to the MCU through VDD and VSS. Because fast signal transitions place high, short-duration current demands on the power supply, use bypass capacitors with high-frequency characteristics and place them as close to the MCU as possible. This 2.5V supply is derived from the internal voltage regulator. There is no static load on those pins allowed. The internal voltage regulator is turned off, if VREGEN is tied to ground.

NOTE: *No load allowed except for bypass capacitors.*

2.4.4 VDDA, VSSA — Power Supply Pins for ATD and VREG

VDDA, VSSA are the power supply and ground input pins for the voltage regulator and the analog to digital converter. It also provides the reference for the internal voltage regulator. This allows the supply voltage to the ATD and the reference voltage to be bypassed independently.

2.4.5 VRH, VRL — ATD Reference Voltage Input Pins

VRH and VRL are the reference voltage input pins for the analog to digital converter.

2.4.6 VDDPLL, VSSPLL — Power Supply Pins for PLL

Provides operating voltage and ground for the Oscillator and the Phased-Locked Loop. This allows the supply voltage to the Oscillator and PLL to be bypassed independently. This 2.5V voltage is generated by the internal voltage regulator.

NOTE: *No load allowed except for bypass capacitors.*

2.4.7 VREGEN — On Chip Voltage Regulator Enable

Enables the internal 5V to 2.5V voltage regulator. If this pin is tied low, VDD1,2 and VDDPLL must be supplied externally.

Section 3 System Clock Description

3.1 Overview

The Clock and Reset Generator provides the internal clock signals for the core and all peripheral modules.

Figure 3-1 shows the clock connections from the CRG to all modules.

Consult the CRG Block Guide and OSC Block Guide for details on clock generation.

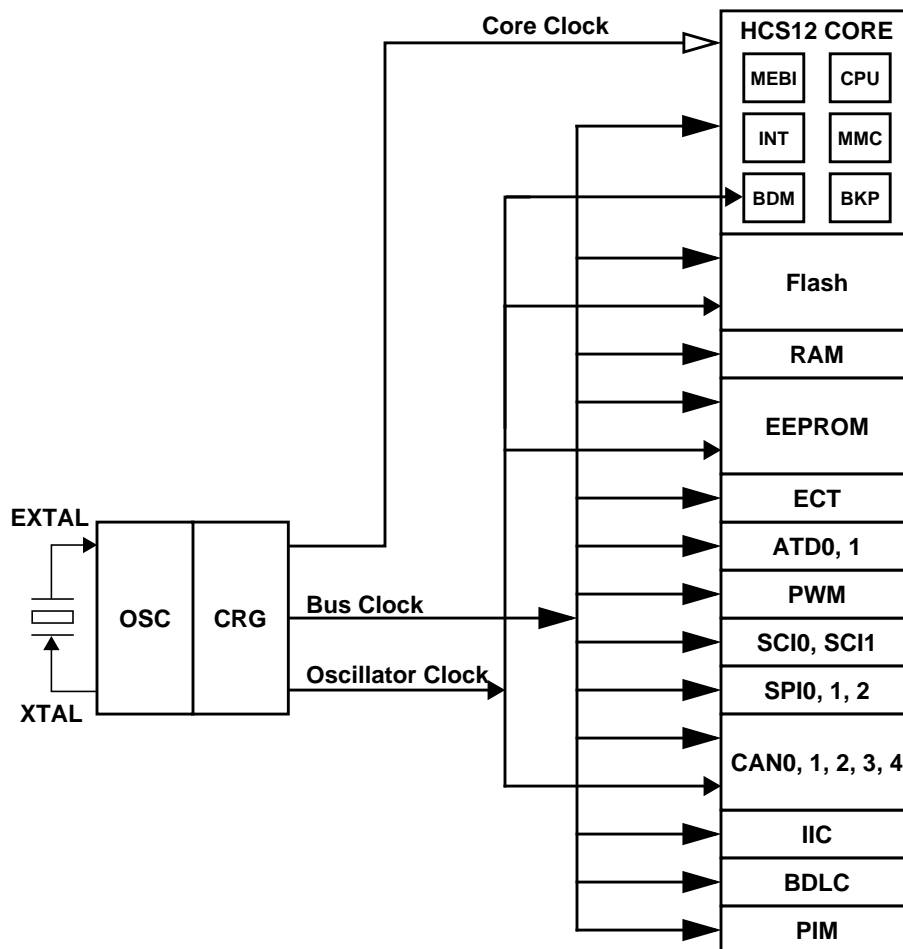

Figure 3-1 Clock Connections



Section 4 Modes of Operation

4.1 Overview

Eight possible modes determine the operating configuration of the MC9S12DP512. Each mode has an associated default memory map and external bus configuration controlled by a further pin.

Three low power modes exist for the device (**Section 4.4 Low Power Modes**).

4.2 Chip Configuration Summary

The operating mode out of reset is determined by the states of the MODC, MODB, and MODA pins during reset (**Table 4-1**). The MODC, MODB, and MODA bits in the MODE register show the current operating mode and provide limited mode switching during operation. The states of the MODC, MODB, and MODA pins are latched into these bits on the rising edge of the reset signal. The ROMCTL signal allows the setting of the ROMON bit in the MISC register thus controlling whether the internal Flash is visible in the memory map. ROMON = 1 means the Flash is visible in the memory map. The state of the ROMCTL pin is latched into the ROMON bit in the MISC register on the rising edge of the reset signal.

Table 4-1 Mode Selection

BKGD = MODC	PE6 = MODB	PE5 = MODA	PK7 = ROMCTL	ROMON Bit	Mode Description
0	0	0	X	1	Special Single Chip, BDM allowed and ACTIVE. BDM is allowed in all other modes but a serial command is required to make BDM active.
0	0	1	0	1	Emulation Expanded Narrow, BDM allowed
			1	0	
0	1	0	X	0	Special Test (Expanded Wide), BDM allowed
0	1	1	0	1	Emulation Expanded Wide, BDM allowed
			1	0	
1	0	0	X	1	Normal Single Chip, BDM allowed
1	0	1	0	0	Normal Expanded Narrow, BDM allowed
			1	1	
1	1	0	X	1	Peripheral; BDM allowed but bus operations would cause bus conflicts (must not be used)
1	1	1	0	0	Normal Expanded Wide, BDM allowed
			1	1	

For further explanation on the modes refer to the HCS12 Multiplexed External Bus Interface (MEBI) Block Guide.

Table 4-2 Clock Selection Based on PE7

PE7 = XCLKS	Description
1	Colpitts Oscillator selected
0	Pierce Oscillator/external clock selected

Table 4-3 Voltage Regulator VREGEN

VREGEN	Description
1	Internal Voltage Regulator enabled
0	Internal Voltage Regulator disabled, VDD1,2 and VDDPLL must be supplied externally with 2.5V

4.3 Security

The device will make available a security feature preventing the unauthorized read and write of the memory contents. This feature allows:

- Protection of the contents of FLASH,
- Protection of the contents of EEPROM,
- Operation in single-chip mode,
- Operation from external memory with internal FLASH and EEPROM disabled.

The user must be reminded that part of the security must lie with the user's code. An extreme example would be user's code that dumps the contents of the internal program. This code would defeat the purpose of security. At the same time the user may also wish to put a back door in the user's program. An example of this is the user downloads a key through the SCI which allows access to a programming routine that updates parameters stored in EEPROM.

4.3.1 Securing the Microcontroller

Once the user has programmed the FLASH and EEPROM (if desired), the part can be secured by programming the security bits located in the FLASH module. These non-volatile bits will keep the part secured through resetting the part and through powering down the part.

The security byte resides in a portion of the Flash array.

Check the Flash Block Guide for more details on the security configuration.

4.3.2 Operation of the Secured Microcontroller

4.3.2.1 Normal Single Chip Mode

This will be the most common usage of the secured part. Everything will appear the same as if the part was not secured with the exception of BDM operation. The BDM operation will be blocked.

4.3.2.2 Executing from External Memory

The user may wish to execute from external space with a secured microcontroller. This is accomplished by resetting directly into expanded mode. The internal FLASH and EEPROM will be disabled. BDM operations will be blocked.

4.3.3 Unsecuring the Microcontroller

In order to unsecure the microcontroller, the internal FLASH and EEPROM must be erased. This can be done through an external program in expanded mode or via a sequence of BDM commands. Unsecuring is also possible via the Backdoor Key Access. Refer to Flash Block Guide for details..

Once the user has erased the FLASH and EEPROM, the part can be reset into special single chip mode. This invokes a program that verifies the erasure of the internal FLASH and EEPROM. Once this program completes, the user can erase and program the FLASH security bits to the unsecured state. This is generally done through the BDM, but the user could also change to expanded mode (by writing the mode bits through the BDM) and jumping to an external program (again through BDM commands). Note that if the part goes through a reset before the security bits are reprogrammed to the unsecure state, the part will be secured again.

4.4 Low Power Modes

The microcontroller features three main low power modes. Consult the respective Block Guide for information on the module behavior in Stop, Pseudo Stop, and Wait Mode. An important source of information about the clock system is the Clock and Reset Generator Block Guide (CRG).

4.4.1 Stop

Executing the CPU STOP instruction stops all clocks and the oscillator thus putting the chip in fully static mode. Wake up from this mode can be done via reset or external interrupts.

4.4.2 Pseudo Stop

This mode is entered by executing the CPU STOP instruction. In this mode the oscillator is still running and the Real Time Interrupt (RTI) or Watchdog (COP) sub module can stay active. Other peripherals are turned off. This mode consumes more current than the full STOP mode, but the wake up time from this mode is significantly shorter.

4.4.3 Wait

This mode is entered by executing the CPU WAI instruction. In this mode the CPU will not execute instructions. The internal CPU signals (address and databus) will be fully static. All peripherals stay active. For further power consumption the peripherals can individually turn off their local clocks.

4.4.4 Run

Although this is not a low power mode, unused peripheral modules should not be enabled in order to save power.

Section 5 Resets and Interrupts

5.1 Overview

Consult the Exception Processing section of the CPU12 Reference Manual for information on resets and interrupts.

5.2 Vectors

5.2.1 Vector Table

Table 5-1 lists interrupt sources and vectors in default order of priority.

Table 5-1 Interrupt Vector Locations

Vector Address	Interrupt Source	CCR Mask	Local Enable	HPRIO Value to Elevate
\$FFFE, \$FFFF	Reset	None	None	–
\$FFFC, \$FFFD	Clock Monitor fail reset	None	PLLCTL (CME, SCME)	–
\$FFFA, \$FFFB	COP failure reset	None	COP rate select	–
\$FFF8, \$FFF9	Unimplemented instruction trap	None	None	–
\$FFF6, \$FFF7	SWI	None	None	–
\$FFF4, \$FFF5	XIRQ	X-Bit	None	–
\$FFF2, \$FFF3	IRQ	I-Bit	IRQCR (IRQEN)	\$F2
\$FFF0, \$FFF1	Real Time Interrupt	I-Bit	CRGINT (RTIE)	\$F0
\$FFEE, \$FFEF	Enhanced Capture Timer channel 0	I-Bit	TIE (C0I)	\$EE
\$FFEC, \$FFED	Enhanced Capture Timer channel 1	I-Bit	TIE (C1I)	\$EC
\$FFEA, \$FFEB	Enhanced Capture Timer channel 2	I-Bit	TIE (C2I)	\$EA
\$FFE8, \$FFE9	Enhanced Capture Timer channel 3	I-Bit	TIE (C3I)	\$E8
\$FFE6, \$FFE7	Enhanced Capture Timer channel 4	I-Bit	TIE (C4I)	\$E6
\$FFE4, \$FFE5	Enhanced Capture Timer channel 5	I-Bit	TIE (C5I)	\$E4
\$FFE2, \$FFE3	Enhanced Capture Timer channel 6	I-Bit	TIE (C6I)	\$E2
\$FFE0, \$FFE1	Enhanced Capture Timer channel 7	I-Bit	TIE (C7I)	\$E0
\$FFDE, \$FFDF	Enhanced Capture Timer overflow	I-Bit	TSRC2 (TOI)	\$DE
\$FFDC, \$FFDD	Pulse accumulator A overflow	I-Bit	PACTL (PAOVI)	\$DC
\$FFDA, \$FFDB	Pulse accumulator input edge	I-Bit	PACTL (PAI)	\$DA
\$FFD8, \$FFD9	SPI0	I-Bit	SPICR1 (SPIE, SPTIE)	\$D8
\$FFD6, \$FFD7	SCI0	I-Bit	SCICR2 (TIE, TCIE, RIE, ILIE)	\$D6
\$FFD4, \$FFD5	SCI1	I-Bit	SCICR2 (TIE, TCIE, RIE, ILIE)	\$D4
\$FFD2, \$FFD3	ATD0	I-Bit	ATDCTL2 (ASCIE)	\$D2
\$FFD0, \$FFD1	ATD1	I-Bit	ATDCTL2 (ASCIE)	\$D0
\$FFCE, \$FFCF	Port J	I-Bit	PIEJ (PIEJ7, PIEJ6, PIEJ1, PIEJ0)	\$CE
\$FFCC, \$FFCD	Port H	I-Bit	PIEH (PIEH7-0)	\$CC

\$FFCA, \$FFCB	Modulus Down Counter underflow	I-Bit	MCCTL (MCZI)	\$CA
\$FFC8, \$FFC9	Pulse Accumulator B Overflow	I-Bit	PBCTL (PBOVI)	\$C8
\$FFC6, \$FFC7	CRG PLL lock	I-Bit	CRGINT (LOCKIE)	\$C6
\$FFC4, \$FFC5	CRG Self Clock Mode	I-Bit	CRGINT (SCMIE)	\$C4
\$FFC2, \$FFC3	BDLC	I-Bit	DLCBCR1 (IE)	\$C2
\$FFC0, \$FFC1	IIC Bus	I-Bit	IBCR (IBIE)	\$C0
\$FFBE, \$FFBF	SPI1	I-Bit	SPICR1 (SPIE, SPTIE)	\$BE
\$FFBC, \$FFBD	SPI2	I-Bit	SPICR1 (SPIE, SPTIE)	\$BC
\$FFBA, \$FFBB	EEPROM	I-Bit	ECNFG (CCIE, CBEIE)	\$BA
\$FFB8, \$FFB9	FLASH	I-Bit	FCNFG (CCIE, CBEIE)	\$B8
\$FFB6, \$FFB7	CAN0 wake-up	I-Bit	CANRIER (WUPIE)	\$B6
\$FFB4, \$FFB5	CAN0 errors	I-Bit	CANRIER (CSCIE, OVRIE)	\$B4
\$FFB2, \$FFB3	CAN0 receive	I-Bit	CANRIER (RXFIE)	\$B2
\$FFB0, \$FFB1	CAN0 transmit	I-Bit	CANTIER (TXEIE2-TXEIE0)	\$B0
\$FFAE, \$FFAF	CAN1 wake-up	I-Bit	CANRIER (WUPIE)	\$AE
\$FFAC, \$FFAD	CAN1 errors	I-Bit	CANRIER (CSCIE, OVRIE)	\$AC
\$FFAA, \$FFAB	CAN1 receive	I-Bit	CANRIER (RXFIE)	\$AA
\$FFA8, \$FFA9	CAN1 transmit	I-Bit	CANTIER (TXEIE2-TXEIE0)	\$A8
\$FFA6, \$FFA7	CAN2 wake-up	I-Bit	CANRIER (WUPIE)	\$A6
\$FFA4, \$FFA5	CAN2 errors	I-Bit	CANRIER (CSCIE, OVRIE)	\$A4
\$FFA2, \$FFA3	CAN2 receive	I-Bit	CANRIER (RXFIE)	\$A2
\$FFA0, \$FFA1	CAN2 transmit	I-Bit	CANTIER (TXEIE2-TXEIE0)	\$A0
\$FF9E, \$FF9F	CAN3 wake-up	I-Bit	CANRIER (WUPIE)	\$9E
\$FF9C, \$FF9D	CAN3 errors	I-Bit	CANRIER (CSCIE, OVRIE)	\$9C
\$FF9A, \$FF9B	CAN3 receive	I-Bit	CANRIER (RXFIE)	\$9A
\$FF98, \$FF99	CAN3 transmit	I-Bit	CANTIER (TXEIE2-TXEIE0)	\$98
\$FF96, \$FF97	CAN4 wake-up	I-Bit	CANRIER (WUPIE)	\$96
\$FF94, \$FF95	CAN4 errors	I-Bit	CANRIER (CSCIE, OVRIE)	\$94
\$FF92, \$FF93	CAN4 receive	I-Bit	CANRIER (RXFIE)	\$92
\$FF90, \$FF91	CAN4 transmit	I-Bit	CANTIER (TXEIE2-TXEIE0)	\$90
\$FF8E, \$FF8F	Port P Interrupt	I-Bit	PIEP (PIEP7-0)	\$8E
\$FF8C, \$FF8D	PWM Emergency Shutdown	I-Bit	PWMSDN (PWMIE)	\$8C
\$FF80 to \$FF8B	Reserved			

5.3 Effects of Reset

When a reset occurs, MCU registers and control bits are changed to known start-up states. Refer to the respective module Block Guides for register reset states.

5.3.1 I/O pins

Refer to the HCS12 Multiplexed External Bus Interface (MEBI) Block Guide for mode dependent pin configuration of port A, B, E and K out of reset.

Refer to the PIM Block Guide for reset configurations of all peripheral module ports.

5.3.2 Memory

Refer to **Table 1-1** for locations of the memories depending on the operating mode after reset.

The RAM array is not automatically initialized out of reset.



Section 6 HCS12 Core Block Description

6.1 CPU12 Block Description

Consult the HCS12 CPU Reference Manual for information on the CPU.

6.1.1 Device-specific information

When the HCS12 CPU Reference Manual refers to *cycles* this is equivalent to *Bus Clock periods*. So *1 cycle* is equivalent to *1 Bus Clock period*.

6.2 HCS12 Module Mapping Control (MMC) Block Description

Consult the MMC Block Guide for information on the HCS12 Module Mapping Control module.

6.2.1 Device-specific information

- INITEE
 - Reset state: \$01
 - Bits EE11-EE15 are "Write once in Normal and Emulation modes and write anytime in Special modes".
- PPAGE
 - Reset state: \$00
 - Register is "Write anytime in all modes"

6.3 HCS12 Multiplexed External Bus Interface (MEBI) Block Description

Consult the MEBI Block Guide for information on HCS12 Multiplexed External Bus Interface module.

6.3.1 Device-specific information

- PUCR
 - Reset state: \$90

6.4 HCS12 Interrupt (INT) Block Description

Consult the INT Block Guide for information on the HCS12 Interrupt module.

6.5 HCS12 Background Debug (BDM) Block Description

Consult the BDM Block Guide for information on the HCS12 Background Debug module.

6.5.1 Device-specific information

When the BDM Block Guide refers to *alternate clock* this is equivalent to *Oscillator Clock*.

6.6 HCS12 Breakpoint (BKP) Block Description

Consult the BKP Block Guide for information on the HCS12 Breakpoint module.

Section 7 Clock and Reset Generator (CRG) Block Description

Consult the CRG Block Guide for information about the Clock and Reset Generator module.

7.1 Device-specific information

The Low Voltage Reset feature of the CRG is not available on this device.

Section 8 Oscillator (OSC) Block Description

8.1 Device-specific information

The $\overline{\text{XCLKS}}$ input signal is active low (see **2.3.13 PE7 / NOACC / XCLKS — Port E I/O Pin 7**).

Section 9 Enhanced Capture Timer (ECT) Block Description

Consult the ECT_16B8C Block Guide for information about the Enhanced Capture Timer module.

When the ECT_16B8C Block Guide refers to *freeze mode* this is equivalent to *active BDM mode*.

Section 10 Analog to Digital Converter (ATD) Block Description

There are two Analog to Digital Converters (ATD1 and ATD0) implemented on the MC9S12DP512. Consult the ATD_10B8C Block Guide for information about each Analog to Digital Converter module. When the ATD_10B8C Block Guide refers to *freeze mode* this is equivalent to *active BDM mode*.

Section 11 Inter-IC Bus (IIC) Block Description

Consult the IIC Block Guide for information about the Inter-IC Bus module.

Section 12 Serial Communications Interface (SCI) Block Description

There are two Serial Communications Interfaces (SCI1 and SCI0) implemented on the MC9S12DP512 device.

Consult the SCI Block Guide for information about each Serial Communications Interface module.

Section 13 Serial Peripheral Interface (SPI) Block Description

There are three Serial Peripheral Interfaces (SPI2, SPI1 and SPI0) implemented on MC9S12DP512.

Consult the SPI Block Guide for information about each Serial Peripheral Interface module.

Section 14 J1850 (BDLC) Block Description

Consult the BDLC Block Guide for information about the J1850 module.

Section 15 Pulse Width Modulator (PWM) Block Description

Consult the PWM_8B6C Block Guide for information about the Pulse Width Modulator module.

When the PWM_8B8C Block Guide refers to *freeze mode* this is equivalent to *active BDM mode*.

Section 16 Flash EEPROM 512K Block Description

Consult the FTS512K4 Block Guide for information about the flash module.

The "S12 LRAE" is a generic Load RAM and Execute (LRAE) program which will be programmed into the flash memory of this device during manufacture. This LRAE program will provide greater programming flexibility to the end users by allowing the device to be programmed directly using CAN or SCI after it is assembled on the PCB. Use of the LRAE program is at the discretion of the end user and, if not required, it must simply be erased prior to flash programming. For more details of the S12 LRAE and its implementation, please see the S12 LREA Application Note (AN2546/D).

It is planned that most HC9S12 devices manufactured after Q1 of 2004 will be shipped with the S12 LRAE programmed in the Flash. Exact details of the changeover (i.e. blank to programmed) for each product will be communicated in advance via GPCN and will be traceable by the customer via datecode marking on the device.

Please contact Freescale Sales if you have any additional questions.

Section 17 EEPROM 4K Block Description

Consult the EETS4K Block Guide for information about the EEPROM module.

Section 18 RAM Block Description

This module supports single-cycle misaligned word accesses.

Section 19 MSCAN Block Description

There are five MSCAN modules (CAN4, CAN3, CAN2, CAN1 and CAN0) implemented on the MC9S12DP512.

Consult the MSCAN Block Guide for information about the Freescale Scalable CAN Module.

Section 20 Port Integration Module (PIM) Block Description

Consult the functionally equivalent PIM_9DP256 Block Guide for information about the Port Integration Module.

Section 21 Voltage Regulator (VREG) Block Description

Consult the VREG Block Guide for information about the dual output linear voltage regulator.

Section 22 Printed Circuit Board Layout Proposal

Table 22-1 Suggested External Component Values

Component	Purpose	Type	Value
C1	VDD1 filter cap	ceramic X7R	100 ... 220nF
C2	VDD2 filter cap	ceramic X7R	100 ... 220nF
C3	VDDA filter cap	ceramic X7R	100nF
C4	VDDR filter cap	X7R/tantalum	$\geq 100\text{nF}$
C5	VDDPLL filter cap	ceramic X7R	100nF
C6	VDDX filter cap	X7R/tantalum	$\geq 100\text{nF}$
C7	OSC load cap		
C8	OSC load cap		
C9 / C _S	PLL loop filter cap	See PLL specification chapter	
C10 / C _P	PLL loop filter cap		
C11 / C _{DC}	DC cutoff cap	Colpitts mode only, if recommended by quartz manufacturer	
R1 / R	PLL loop filter res	See PLL Specification chapter	
R2 / R _B		Pierce mode only	
R3 / R _S			
Q1	Quartz		

The PCB must be carefully laid out to ensure proper operation of the voltage regulator as well as of the MCU itself. The following rules must be observed:

- Every supply pair must be decoupled by a ceramic capacitor connected as near as possible to the corresponding pins (C1 – C6).
- Central point of the ground star should be the VSSR pin.
- Use low ohmic low inductance connections between VSS1, VSS2 and VSSR.
- VSSPLL must be directly connected to VSSR.
- Keep traces of VSSPLL, EXTAL and XTAL as short as possible and occupied board area for C7, C8, C11 and Q1 as small as possible.
- Do not place other signals or supplies underneath area occupied by C7, C8, C10 and Q1 and the connection area to the MCU.
- Central power input should be fed in at the VDDA/VSSA pins.

Figure 22-1 Recommended PCB Layout for 112LQFP Colpitts Oscillator

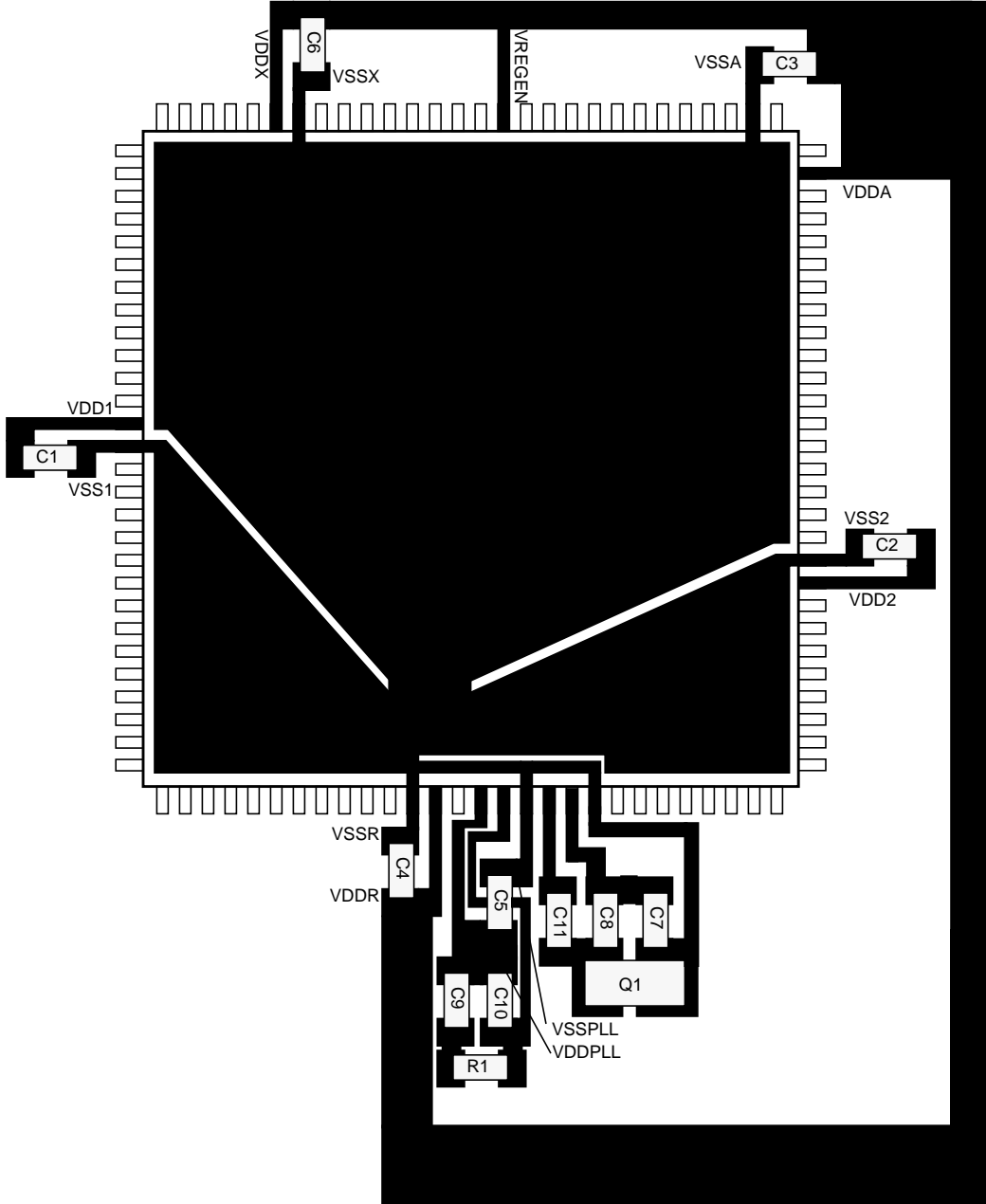
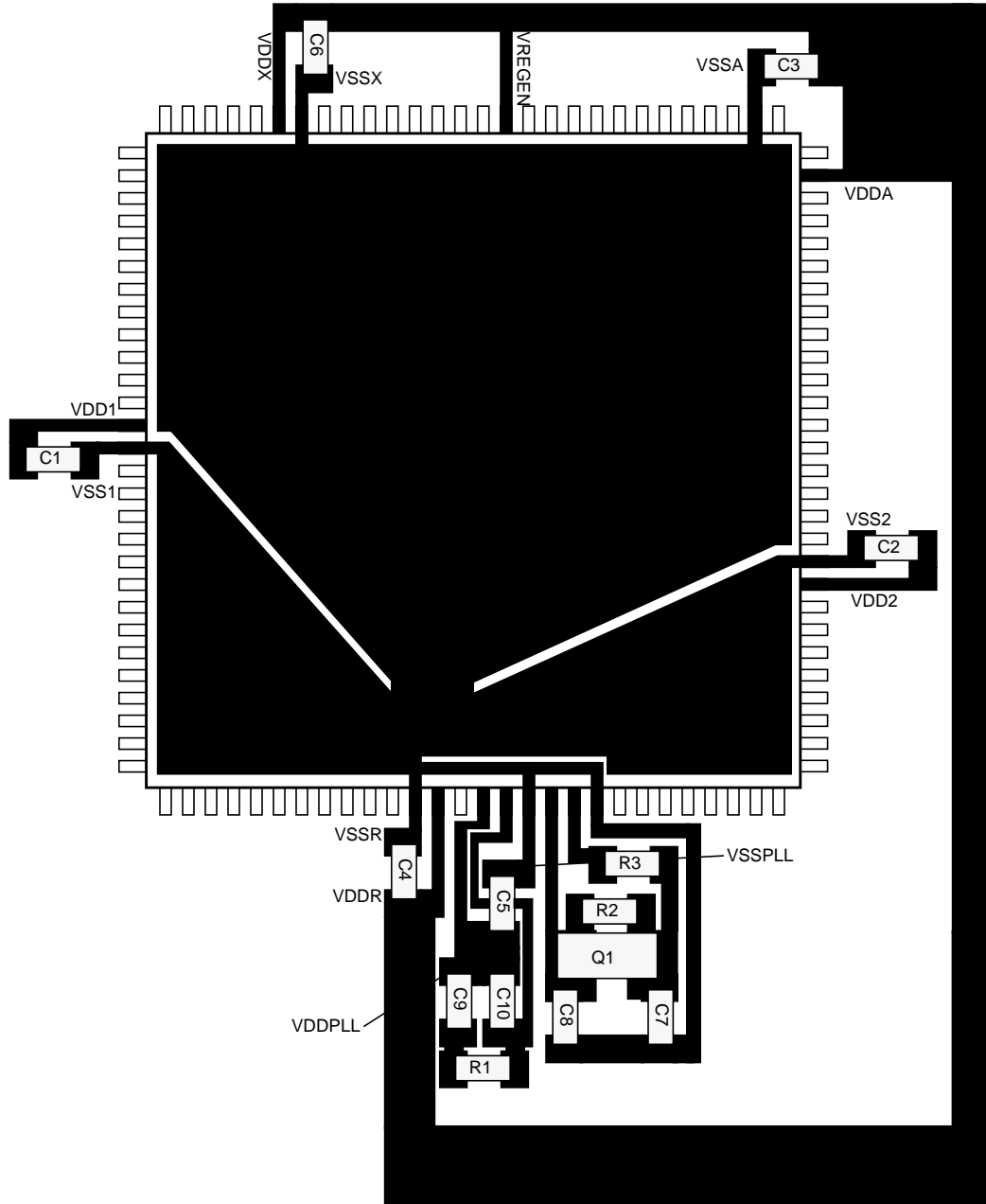

Figure 22-2 Recommended PCB Layout for 112LQFP Pierce Oscillator





Appendix A Electrical Characteristics

A.1 General

NOTE: *The electrical characteristics given in this section are preliminary and should be used as a guide only. Values cannot be guaranteed by Freescale and are subject to change without notice.*

This supplement contains the most accurate electrical information for the MC9S12DP512 microcontroller available at the time of publication. The information should be considered **PRELIMINARY** and is subject to change.

This introduction is intended to give an overview on several common topics like power supply, current injection etc.

A.1.1 Parameter Classification

The electrical parameters shown in this supplement are guaranteed by various methods. To give the customer a better understanding the following classification is used and the parameters are tagged accordingly in the tables where appropriate.

NOTE: *This classification is shown in the column labeled “C” in the parameter tables where appropriate.*

P:

Those parameters are guaranteed during production testing on each individual device.

C:

Those parameters are achieved by the design characterization by measuring a statistically relevant sample size across process variations.

T:

Those parameters are achieved by design characterization on a small sample size from typical devices under typical conditions unless otherwise noted. All values shown in the typical column are within this category.

D:

Those parameters are derived mainly from simulations.

A.1.2 Power Supply

The MC9S12DP512 utilizes several pins to supply power to the I/O ports, A/D converter, oscillator, PLL and internal logic.

The VDDA, VSSA pair supplies the A/D converter and the resistor ladder of the internal voltage regulator.

The VDDX, VSSX, VDDR and VSSR pairs supply the I/O pins, VDDR supplies also the internal voltage regulator.

VDD1, VSS1, VDD2 and VSS2 are the supply pins for the digital logic, VDDPLL, VSSPLL supply the oscillator and the PLL.

VSS1 and VSS2 are internally connected by metal.

VDDA, VDDX, VDDR as well as VSSA, VSSX, VSSR are connected by anti-parallel diodes for ESD protection.

NOTE: *In the following context VDD5 is used for either VDDA, VDDR and VDDX; VSS5 is used for either VSSA, VSSR and VSSX unless otherwise noted. IDD5 denotes the sum of the currents flowing into the VDDA, VDDX and VDDR pins. VDD is used for VDD1, VDD2 and VDDPLL, VSS is used for VSS1, VSS2 and VSSPLL. IDD is used for the sum of the currents flowing into VDD1 and VDD2.*

A.1.3 Pins

There are four groups of functional pins.

A.1.3.1 5V I/O pins

Those I/O pins have a nominal level of 5V. This class of pins is comprised of all port I/O pins, the analog inputs, BKGD and the RESET pins. The internal structure of all those pins is identical, however some of the functionality may be disabled. E.g. for the analog inputs the output drivers, pull-up and pull-down resistors are disabled permanently.

A.1.3.2 Analog Reference

This group is made up by the VRH and VRL pins.

A.1.3.3 Oscillator

The pins XFC, EXTAL, XTAL dedicated to the oscillator have a nominal 2.5V level. They are supplied by VDDPLL.

A.1.3.4 TEST

This pin is used for production testing only.

A.1.3.5 VREGEN

This pin is used to enable the on chip voltage regulator.

A.1.4 Current Injection

Power supply must maintain regulation within operating V_{DD5} or V_{DD} range during instantaneous and operating maximum current conditions. If positive injection current ($V_{in} > V_{DD5}$) is greater than I_{DD5} , the injection current may flow out of VDD5 and could result in external power supply going out of regulation. Ensure external VDD5 load will shunt current greater than maximum injection current. This will be the greatest risk when the MCU is not consuming power; e.g. if no system clock is present, or if clock rate is very low which would reduce overall power consumption.

A.1.5 Absolute Maximum Ratings

Absolute maximum ratings are stress ratings only. A functional operation under or outside those maxima is not guaranteed. Stress beyond those limits may affect the reliability or cause permanent damage of the device.

This device contains circuitry protecting against damage due to high static voltage or electrical fields; however, it is advised that normal precautions be taken to avoid application of any voltages higher than maximum-rated voltages to this high-impedance circuit. Reliability of operation is enhanced if unused inputs are tied to an appropriate logic voltage level (e.g., either V_{SS5} or V_{DD5}).

Table A-1 Absolute Maximum Ratings¹

Num	Rating	Symbol	Min	Max	Unit
1	I/O, Regulator and Analog Supply Voltage	V_{DD5}	-0.3	6.0	V
2	Digital Logic Supply Voltage ²	V_{DD}	-0.3	3.0	V
3	PLL Supply Voltage ⁽²⁾	V_{DDPLL}	-0.3	3.0	V
4	Voltage difference VDDX to VDDR and VDDA	ΔV_{DDX}	-0.3	0.3	V
5	Voltage difference VSSX to VSSR and VSSA	ΔV_{SSX}	-0.3	0.3	V
6	Digital I/O Input Voltage	V_{IN}	-0.3	6.0	V
7	Analog Reference	V_{RH}, V_{RL}	-0.3	6.0	V
8	XFC, EXTAL, XTAL inputs	V_{ILV}	-0.3	3.0	V
9	TEST input	V_{TEST}	-0.3	10.0	V
10	Instantaneous Maximum Current Single pin limit for all digital I/O pins ³	I_D	-25	+25	mA
11	Instantaneous Maximum Current Single pin limit for XFC, EXTAL, XTAL ⁴	I_{DL}	-25	+25	mA
12	Instantaneous Maximum Current Single pin limit for TEST ⁵	I_{DT}	-0.25	0	mA
13	Storage Temperature Range	T_{stg}	- 65	155	°C

NOTES:

1. Beyond absolute maximum ratings device might be damaged.

2. The device contains an internal voltage regulator to generate the logic and PLL supply out of the I/O supply. The absolute maximum ratings apply when the device is powered from an external source.
3. All digital I/O pins are internally clamped to V_{SSX} and V_{DDX} , V_{SSR} and V_{DDR} or V_{SSA} and V_{DDA} .
4. Those pins are internally clamped to V_{SSPLL} and V_{DDPLL} .
5. This pin is clamped low to V_{SSX} , but not clamped high. This pin must be tied low in applications.

A.1.6 ESD Protection and Latch-up Immunity

All ESD testing is in conformity with CDF-AEC-Q100 Stress test qualification for Automotive Grade Integrated Circuits. During the device qualification ESD stresses were performed for the Human Body Model (HBM), the Machine Model (MM) and the Charge Device Model.

A device will be defined as a failure if after exposure to ESD pulses the device no longer meets the device specification. Complete DC parametric and functional testing is performed per the applicable device specification at room temperature followed by hot temperature, unless specified otherwise in the device specification.

Table A-2 ESD and Latch-up Test Conditions

Model	Description	Symbol	Value	Unit
Human Body	Series Resistance	R1	1500	Ohm
	Storage Capacitance	C	100	pF
	Number of Pulse per pin positive negative	-	- 3 3	
Machine	Series Resistance	R1	0	Ohm
	Storage Capacitance	C	200	pF
	Number of Pulse per pin positive negative	-	- 3 3	
Latch-up	Minimum input voltage limit		-2.5	V
	Maximum input voltage limit		7.5	V

Table A-3 ESD and Latch-up Protection Characteristics

Num	C	Rating	Symbol	Min	Max	Unit
1	C	Human Body Model (HBM)	V_{HBM}	2000	-	V
2	C	Machine Model (MM)	V_{MM}	200	-	V
3	C	Charge Device Model (CDM)	V_{CDM}	500	-	V
4	C	Latch-up Current at $T_A = 125^\circ\text{C}$ positive negative	I_{LAT}	+100 -100	-	mA
5	C	Latch-up Current at $T_A = 27^\circ\text{C}$ positive negative	I_{LAT}	+200 -200	-	mA

A.1.7 Operating Conditions

This chapter describes the operating conditions of the device. Unless otherwise noted those conditions apply to all the following data.

NOTE: Please refer to the temperature rating of the device (C, V, M) with regards to the ambient temperature T_A and the junction temperature T_J . For power dissipation calculations refer to **Section A.1.8 Power Dissipation and Thermal Characteristics**.

Table A-4 Operating Conditions

Rating	Symbol	Min	Typ	Max	Unit
I/O, Regulator and Analog Supply Voltage	V_{DD5}	4.5	5	5.25	V
Digital Logic Supply Voltage ¹	V_{DD}	2.35	2.5	2.75	V
PLL Supply Voltage ⁽¹⁾	V_{DDPLL}	2.35	2.5	2.75	V
Voltage Difference VDDX to VDDR and VDDA	ΔV_{DDX}	-0.1	0	0.1	V
Voltage Difference VSSX to VSSR and VSSA	ΔV_{SSX}	-0.1	0	0.1	V
Bus Frequency (MC9S12DP512C, V, M)	f_{bus}	0.25 ²	-	25	MHz
MC9S12DP512C					
Operating Junction Temperature Range	T_J	-40	-	100	°C
Operating Ambient Temperature Range ³	T_A	-40	27	85	°C
MC9S12DP512V					
Operating Junction Temperature Range	T_J	-40	-	120	°C
Operating Ambient Temperature Range ⁽³⁾	T_A	-40	27	105	°C
MC9S12DP512M					
Operating Junction Temperature Range	T_J	-40	-	140	°C
Operating Ambient Temperature Range ⁽³⁾	T_A	-40	27	125	°C

NOTES:

1. The device contains an internal voltage regulator to generate the logic and PLL supply out of the I/O supply. The given operating range applies when this regulator is disabled and the device is powered from an external source.
2. Some blocks e.g. ATD (conversion) and NVMs (program/erase) require higher bus frequencies for proper operation.
3. Please refer to **Section A.1.8 Power Dissipation and Thermal Characteristics** for more details about the relation between ambient temperature T_A and device junction temperature T_J .

A.1.8 Power Dissipation and Thermal Characteristics

Power dissipation and thermal characteristics are closely related. The user must assure that the maximum operating junction temperature is not exceeded. The average chip-junction temperature (T_J) in °C can be obtained from:

$$T_J = T_A + (P_D \cdot \Theta_{JA})$$

T_J = Junction Temperature, [°C]

T_A = Ambient Temperature, [°C]

P_D = Total Chip Power Dissipation, [W]

Θ_{JA} = Package Thermal Resistance, [°C/W]

The total power dissipation can be calculated from:

$$P_D = P_{INT} + P_{IO}$$

P_{INT} = Chip Internal Power Dissipation, [W]

Two cases with internal voltage regulator enabled and disabled must be considered:

1. Internal Voltage Regulator disabled

$$P_{INT} = I_{DD} \cdot V_{DD} + I_{DDPLL} \cdot V_{DDPLL} + I_{DDA} \cdot V_{DDA}$$

$$P_{IO} = \sum_i R_{DSON} \cdot I_{IO_i}^2$$

P_{IO} is the sum of all output currents on I/O ports associated with VDDX and VDDR.

For R_{DSON} is valid:

$$R_{DSON} = \frac{V_{OL}}{I_{OL}}; \text{for outputs driven low}$$

respectively

$$R_{DSON} = \frac{V_{DD5} - V_{OH}}{I_{OH}}; \text{for outputs driven high}$$

2. Internal voltage regulator enabled

$$P_{INT} = I_{DDR} \cdot V_{DDR} + I_{DDA} \cdot V_{DDA}$$

I_{DDR} is the current shown in **Table A-7** and not the overall current flowing into VDDR, which additionally contains the current flowing into the external loads with output high.

$$P_{IO} = \sum_i R_{DSON} \cdot I_{IO_i}^2$$

P_{IO} is the sum of all output currents on I/O ports associated with VDDX and VDDR.

Table A-5 Thermal Package Characteristics¹

Num	C	Rating	Symbol	Min	Typ	Max	Unit
1	T	Thermal Resistance LQFP112, single sided PCB ²	θ_{JA}	-	-	54	°C/W
2	T	Thermal Resistance LQFP112, double sided PCB with 2 internal planes ³	θ_{JA}	-	-	41	°C/W

NOTES:

1. The values for thermal resistance are achieved by package simulations
2. PC Board according to EIA/JEDEC Standard 51-2
3. PC Board according to EIA/JEDEC Standard 51-7

A.1.9 I/O Characteristics

This section describes the characteristics of all 5V I/O pins. All parameters are not always applicable, e.g. not all pins feature pull up/down resistances.

Table A-6 5V I/O Characteristics

Conditions are shown in Table A-4 unless otherwise noted							
Num	C	Rating	Symbol	Min	Typ	Max	Unit
1	P	Input High Voltage	V_{IH}	$0.65 \cdot V_{DD5}$	-	-	V
	T	Input High Voltage	V_{IH}	-	-	$V_{DD5} + 0.3$	V
2	P	Input Low Voltage	V_{IL}	-	-	$0.35 \cdot V_{DD5}$	V
	T	Input Low Voltage	V_{IL}	$V_{SS5} - 0.3$	-	-	V
3	C	Input Hysteresis	V_{HYS}	-	250	-	mV
4	P	Input Leakage Current (pins in high impedance input mode) $V_{in} = V_{DD5}$ or V_{SS5}	I_{in}	-1	-	1	μA
5	P	Output High Voltage (pins in output mode) Partial Drive $I_{OH} = -2mA$ Full Drive $I_{OH} = -10mA$	V_{OH}	$V_{DD5} - 0.8$	-	-	V
6	P	Output Low Voltage (pins in output mode) Partial Drive $I_{OL} = +2mA$ Full Drive $I_{OL} = +10mA$	V_{OL}	-	-	0.8	V
7	P	Internal Pull Up Device Current, tested at V_{IL} Max.	I_{PUL}	-	-	-130	μA
8	C	Internal Pull Up Device Current, tested at V_{IH} Min.	I_{PUH}	-10	-	-	μA
9	P	Internal Pull Down Device Current, tested at V_{IH} Min.	I_{PDH}	-	-	130	μA
10	C	Internal Pull Down Device Current, tested at V_{IL} Max.	I_{PDL}	10	-	-	μA
11	D	Input Capacitance	C_{in}	-	6	-	pF
12	T	Injection current ¹ Single Pin limit Total Device Limit. Sum of all injected currents	I_{ICS} I_{ICP}	-2.5 -25	-	2.5 25	mA
13	P	Port H, J, P Interrupt Input Pulse filtered ²	t_{PIGN}	-	-	3	μs
14	P	Port H, J, P Interrupt Input Pulse passed ⁽²⁾	t_{PVAL}	10	-	-	μs

NOTES:

1. Refer to **Section A.1.4 Current Injection**, for more details
2. Parameter only applies in STOP or Pseudo STOP mode.

A.1.10 Supply Currents

This section describes the current consumption characteristics of the device as well as the conditions for the measurements.

A.1.10.1 Measurement Conditions

All measurements are without output loads. Unless otherwise noted the currents are measured in single chip mode, internal voltage regulator enabled and at 25MHz bus frequency using a 4MHz oscillator in Colpitts mode. Production testing is performed using a square wave signal at the EXTAL input.

A.1.10.2 Additional Remarks

In expanded modes the currents flowing in the system are highly dependent on the load at the address, data and control signals as well as on the duty cycle of those signals. No generally applicable numbers can be given. A very good estimate is to take the single chip currents and add the currents due to the external loads.

Table A-7 Supply Current Characteristics

Conditions are shown in Table A-4 unless otherwise noted							
Num	C	Rating	Symbol	Min	Typ	Max	Unit
1	P	Run supply currents Single Chip, Internal regulator enabled	I_{DD5}	-	-	65	mA
2	P P	Wait Supply current All modules enabled, PLL on only RTI enabled ⁽¹⁾	I_{DDW}	-	-	40 5	mA
3	C P C C P C P C P	Pseudo Stop Current (RTI and COP disabled) ^{1, 2} -40°C 27°C 70°C 85°C "C" Temp Option 100°C 105°C "V" Temp Option 120°C 125°C "M" Temp Option 140°C	I_{DDPS}	-	370 400 450 550 600 650 800 850 1200	500 1600	μA
4	C C C C C C C C	Pseudo Stop Current (RTI and COP enabled) ^{(1), (2)} -40°C 27°C 70°C 85°C 105°C 125°C 140°C	I_{DDPS}	-	570 600 650 750 850 1200 1500	-	μA
5	C P C C P C P C P	Stop Current ⁽²⁾ -40°C 27°C 70°C 85°C "C" Temp Option 100°C 105°C "V" Temp Option 120°C 125°C "M" Temp Option 140°C	I_{DDS}	-	12 25 100 130 160 200 350 400 600	100 1200 1700 5000	μA

MC9S12DP512 Device Guide V01.25

NOTES:

1. PLL off
2. At those low power dissipation levels $T_J = T_A$ can be assumed

A.2 ATD Characteristics

This section describes the characteristics of the analog to digital converter.

A.2.1 ATD Operating Characteristics

The **Table A-8** shows conditions under which the ATD operates.

The following constraints exist to obtain full-scale, full range results:

$V_{SSA} \leq V_{RL} \leq V_{IN} \leq V_{RH} \leq V_{DDA}$. This constraint exists since the sample buffer amplifier can not drive beyond the power supply levels that it ties to. If the input level goes outside of this range it will effectively be clipped.

Table A-8 ATD Operating Characteristics

Conditions are shown in Table A-4 unless otherwise noted							
Num	C	Rating	Symbol	Min	Typ	Max	Unit
1	D	Reference Potential Low High	V_{RL} V_{RH}	V_{SSA} $V_{DDA}/2$	-	$V_{DDA}/2$ V_{DDA}	V V
2	C	Differential Reference Voltage ¹	$V_{RH}-V_{RL}$	4.50	5.00	5.25	V
3	D	ATD Clock Frequency	f_{ATDCLK}	0.5	-	2.0	MHz
4	D	ATD 10-Bit Conversion Period Clock Cycles ² Conv, Time at 2.0MHz ATD Clock f_{ATDCLK}	N_{CONV10} T_{CONV10}	14 7	-	28 14	Cycles μs
5	D	ATD 8-Bit Conversion Period Clock Cycles ⁽²⁾ Conv, Time at 2.0MHz ATD Clock f_{ATDCLK}	N_{CONV8} T_{CONV8}	12 6	-	26 13	Cycles μs
6	D	Recovery Time ($V_{DDA}=5.0$ Volts)	t_{REC}	-	-	20	μs
7	P	Reference Supply current 2 ATD blocks on	I_{REF}	-	-	0.750	mA
8	P	Reference Supply current 1 ATD block on	I_{REF}	-	-	0.375	mA

NOTES:

1. Full accuracy is not guaranteed when differential voltage is less than 4.50V
2. The minimum time assumes a final sample period of 2 ATD clocks cycles while the maximum time assumes a final sample period of 16 ATD clocks.

A.2.2 Factors influencing accuracy

Three factors - source resistance, source capacitance and current injection - have an influence on the accuracy of the ATD.

A.2.2.1 Source Resistance

Due to the input pin leakage current as specified in **Table A-6** in conjunction with the source resistance there will be a voltage drop from the signal source to the ATD input. The maximum source resistance R_S

specifies results in an error of less than 1/2 LSB (2.5mV) at the maximum leakage current. If device or operating conditions are less than worst case or leakage-induced error is acceptable, larger values of source resistance is allowed.

A.2.2.2 Source Capacitance

When sampling an additional internal capacitor is switched to the input. This can cause a voltage drop due to charge sharing with the external and the pin capacitance. For a maximum sampling error of the input voltage $\leq 1\text{LSB}$, then the external filter capacitor, $C_f \geq 1024 * (C_{INS} - C_{INN})$.

A.2.2.3 Current Injection

There are two cases to consider.

1. A current is injected into the channel being converted. The channel being stressed has conversion values of \$3FF (\$FF in 8-bit mode) for analog inputs greater than V_{RH} and \$000 for values less than V_{RL} unless the current is higher than specified as disruptive condition.
2. Current is injected into pins in the neighborhood of the channel being converted. A portion of this current is picked up by the channel (coupling ratio K), This additional current impacts the accuracy of the conversion depending on the source resistance.

The additional input voltage error on the converted channel can be calculated as $V_{ERR} = K * R_S * I_{INJ}$, with I_{INJ} being the sum of the currents injected into the two pins adjacent to the converted channel.

Table A-9 ATD Electrical Characteristics

Conditions are shown in Table A-4 unless otherwise noted							
Num	C	Rating	Symbol	Min	Typ	Max	Unit
1	C	Max input Source Resistance	R_S	-	-	1	K Ω
2	T	Total Input Capacitance Non Sampling Sampling	C_{INN} C_{INS}	-	-	10 22	pF
3	C	Disruptive Analog Input Current	I_{NA}	-2.5	-	2.5	mA
4	C	Coupling Ratio positive current injection	K_p	-	-	10^{-4}	A/A
5	C	Coupling Ratio negative current injection	K_n	-	-	10^{-2}	A/A

A.2.3 ATD accuracy

Table A-10 specifies the ATD conversion performance excluding any errors due to current injection, input capacitance and source resistance.

Table A-10 ATD Conversion Performance

Conditions are shown in Table A-4 unless otherwise noted $V_{REF} = V_{RH} - V_{RL} = 5.12V$. Resulting to one 8 bit count = 20mV and one 10 bit count = 5mV $f_{ATDCLK} = 2.0MHz$							
Num	C	Rating	Symbol	Min	Typ	Max	Unit
1	P	10-Bit Resolution	LSB	-	5	-	mV
2	P	10-Bit Differential Nonlinearity	DNL	-1	-	1	Counts
3	P	10-Bit Integral Nonlinearity	INL	-2.5	±1.5	2.5	Counts
4	P	10-Bit Absolute Error ¹	AE	-3	±2.0	3	Counts
5	P	8-Bit Resolution	LSB	-	20	-	mV
6	P	8-Bit Differential Nonlinearity	DNL	-0.5	-	0.5	Counts
7	P	8-Bit Integral Nonlinearity	INL	-1.0	±0.5	1.0	Counts
8	P	8-Bit Absolute Error ⁽¹⁾	AE	-1.5	±1.0	1.5	Counts

NOTES:

1. These values include the quantization error which is inherently 1/2 count for any A/D converter.

For the following definitions see also **Figure A-1**.

Differential Non-Linearity (DNL) is defined as the difference between two adjacent switching steps.

$$DNL(i) = \frac{V_i - V_{i-1}}{1LSB} - 1$$

The Integral Non-Linearity (INL) is defined as the sum of all DNLs:

$$INL(n) = \sum_{i=1}^n DNL(i) = \frac{V_n - V_0}{1LSB} - n$$

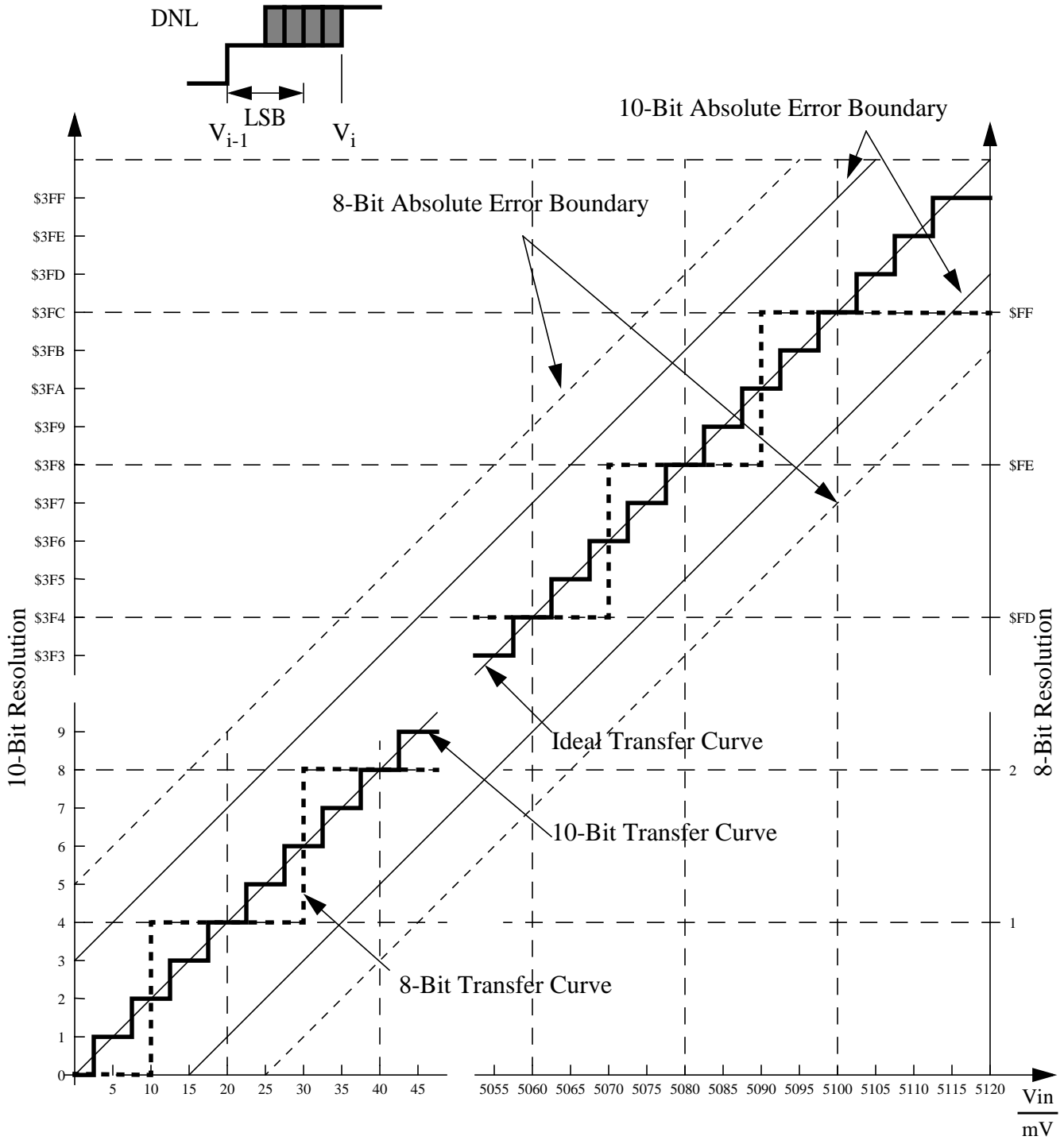

Figure A-1 ATD Accuracy Definitions

NOTE: Figure A-1 shows only definitions, for specification values refer to Table A-10.

A.3 NVM, Flash and EEPROM

NOTE: Unless otherwise noted the abbreviation NVM (Non Volatile Memory) is used for both Flash and EEPROM.

A.3.1 NVM timing

The time base for all NVM program or erase operations is derived from the oscillator. A minimum oscillator frequency f_{NVMOSC} is required for performing program or erase operations. The NVM modules do not have any means to monitor the frequency and will not prevent program or erase operation at frequencies above or below the specified minimum. Attempting to program or erase the NVM modules at a lower frequency a full program or erase transition is not assured.

The Flash and EEPROM program and erase operations are timed using a clock derived from the oscillator using the FCLKDIV and ECLKDIV registers respectively. The frequency of this clock must be set within the limits specified as f_{NVMOP} .

The minimum program and erase times shown in **Table A-11** are calculated for maximum f_{NVMOP} and maximum f_{bus} . The maximum times are calculated for minimum f_{NVMOP} and a f_{bus} of 2MHz.

A.3.1.1 Single Word Programming

The programming time for single word programming is dependant on the bus frequency as a well as on the frequency f_{NVMOP} and can be calculated according to the following formula.

$$t_{\text{swpgm}} = 9 \cdot \frac{1}{f_{\text{NVMOP}}} + 25 \cdot \frac{1}{f_{\text{bus}}}$$

A.3.1.2 Row Programming

This applies only to the Flash where up to 64 words in a row can be programmed consecutively by keeping the command pipeline filled. The time to program a consecutive word can be calculated as:

$$t_{\text{bwpgm}} = 4 \cdot \frac{1}{f_{\text{NVMOP}}} + 9 \cdot \frac{1}{f_{\text{bus}}}$$

The time to program a whole row is:

$$t_{\text{brpgm}} = t_{\text{swpgm}} + 63 \cdot t_{\text{bwpgm}}$$

Row programming is more than 2 times faster than single word programming.

A.3.1.3 Sector Erase

Erasing a 1024 byte Flash sector or a 4 byte EEPROM sector takes:

$$t_{\text{era}} \approx 4000 \cdot \frac{1}{f_{\text{NVMOP}}}$$

The setup time can be ignored for this operation.

A.3.1.4 Mass Erase

Erasing a NVM block takes:

$$t_{\text{mass}} \approx 20000 \cdot \frac{1}{f_{\text{NVMOP}}}$$

The setup time can be ignored for this operation.

A.3.1.5 Blank Check

The time it takes to perform a blank check on the Flash or EEPROM is dependant on the location of the first non-blank word starting at relative address zero. It takes one bus cycle per word to verify plus a setup of the command.

$$t_{\text{check}} \approx \text{location} \cdot t_{\text{cyc}} + 10 \cdot t_{\text{cyc}}$$

Table A-11 NVM Timing Characteristics

Conditions are shown in Table A-4 unless otherwise noted							
Num	C	Rating	Symbol	Min	Typ	Max	Unit
1	D	External Oscillator Clock	f_{NVMOSC}	0.5	-	50 ¹	MHz
2	D	Bus frequency for Programming or Erase Operations	f_{NVMBUS}	1	-	-	MHz
3	D	Operating Frequency	f_{NVMOP}	150	-	200	kHz
4	P	Single Word Programming Time	t_{swpgm}	46 ²	-	74.5 ³	μs
5	D	Flash Row Programming consecutive word ⁴	t_{bwpgm}	20.4 ⁽²⁾	-	31 ⁽³⁾	μs
6	D	Flash Row Programming Time for 64 Words ⁽⁴⁾	t_{brpgm}	1331.2 ⁽²⁾	-	2027.5 ⁽³⁾	μs
7	P	Sector Erase Time	t_{era}	20 ⁵	-	26.7 ⁽³⁾	ms
8	P	Mass Erase Time	t_{mass}	100 ⁽⁵⁾	-	133 ⁽³⁾	ms
9	D	Blank Check Time Flash per block	t_{check}	11 ⁶	-	65546 ⁷	t_{cyc}
10	D	Blank Check Time EEPROM per block	t_{check}	11 ⁽⁶⁾	-	2058 ⁽⁷⁾	t_{cyc}

NOTES:

- Restrictions for oscillator in crystal mode apply!
- Minimum Programming times are achieved under maximum NVM operating frequency f_{NVMOP} and maximum bus frequency f_{bus} .
- Maximum Erase and Programming times are achieved under particular combinations of f_{NVMOP} and bus frequency f_{bus} . Refer to formulae in Sections **Section A.3.1.1 Single Word Programming- Section A.3.1.4 Mass Erase** for guidance.
- Row Programming operations are not applicable to EEPROM
- Minimum Erase times are achieved under maximum NVM operating frequency f_{NVMOP} .
- Minimum time, if first word in the array is not blank
- Maximum time to complete check on an erased block

A.3.2 NVM Reliability

The reliability of the NVM blocks is guaranteed by stress test during qualification, constant process monitors and burn-in to screen early life failures.

The program/erase cycle count on the sector is incremented every time a sector or mass erase event is executed

Table A-12 NVM Reliability Characteristics¹

Conditions are shown in Table A-4 unless otherwise noted							
Num	C	Rating	Symbol	Min	Typ	Max	Unit
Flash Reliability Characteristics							
1	C	Data retention after 10,000 program/erase cycles at an average junction temperature of $T_{Javg} \leq 85^{\circ}\text{C}$	t_{FLRET}	15	100^2	—	Years
2	C	Data retention with <100 program/erase cycles at an average junction temperature $T_{Javg} \leq 85^{\circ}\text{C}$		20	100^2	—	
3	C	Number of program/erase cycles ($-40^{\circ}\text{C} \leq T_J \leq 0^{\circ}\text{C}$)	n_{FL}	10,000	—	—	Cycles
4	C	Number of program/erase cycles ($0^{\circ}\text{C} \leq T_J \leq 140^{\circ}\text{C}$)		10,000	$100,000^3$	—	
EEPROM Reliability Characteristics							
5	C	Data retention after up to 100,000 program/erase cycles at an average junction temperature of $T_{Javg} \leq 85^{\circ}\text{C}$	t_{EEPRET}	15	100^2	—	Years
6	C	Data retention with <100 program/erase cycles at an average junction temperature $T_{Javg} \leq 85^{\circ}\text{C}$		20	100^2	—	
7	C	Number of program/erase cycles ($-40^{\circ}\text{C} \leq T_J \leq 0^{\circ}\text{C}$)	n_{EEP}	10,000	—	—	Cycles
8	C	Number of program/erase cycles ($0^{\circ}\text{C} < T_J \leq 140^{\circ}\text{C}$)		100,000	$300,000^3$	—	

NOTES:

- T_{Javg} will not exceed 85°C considering a typical temperature profile over the lifetime of a consumer, industrial or automotive application.
- Typical data retention values are based on intrinsic capability of the technology measured at high temperature and de-rated to 25°C using the Arrhenius equation. For additional information on how Freescale defines Typical Data Retention, please refer to Engineering Bulletin EB618.
- Spec table quotes typical endurance evaluated at 25°C for this product family, typical endurance at various temperature can be estimated using the graph below. For additional information on how Freescale defines Typical Endurance, please refer to Engineering Bulletin EB619.

Figure A-2 Typical Endurance vs Temperature

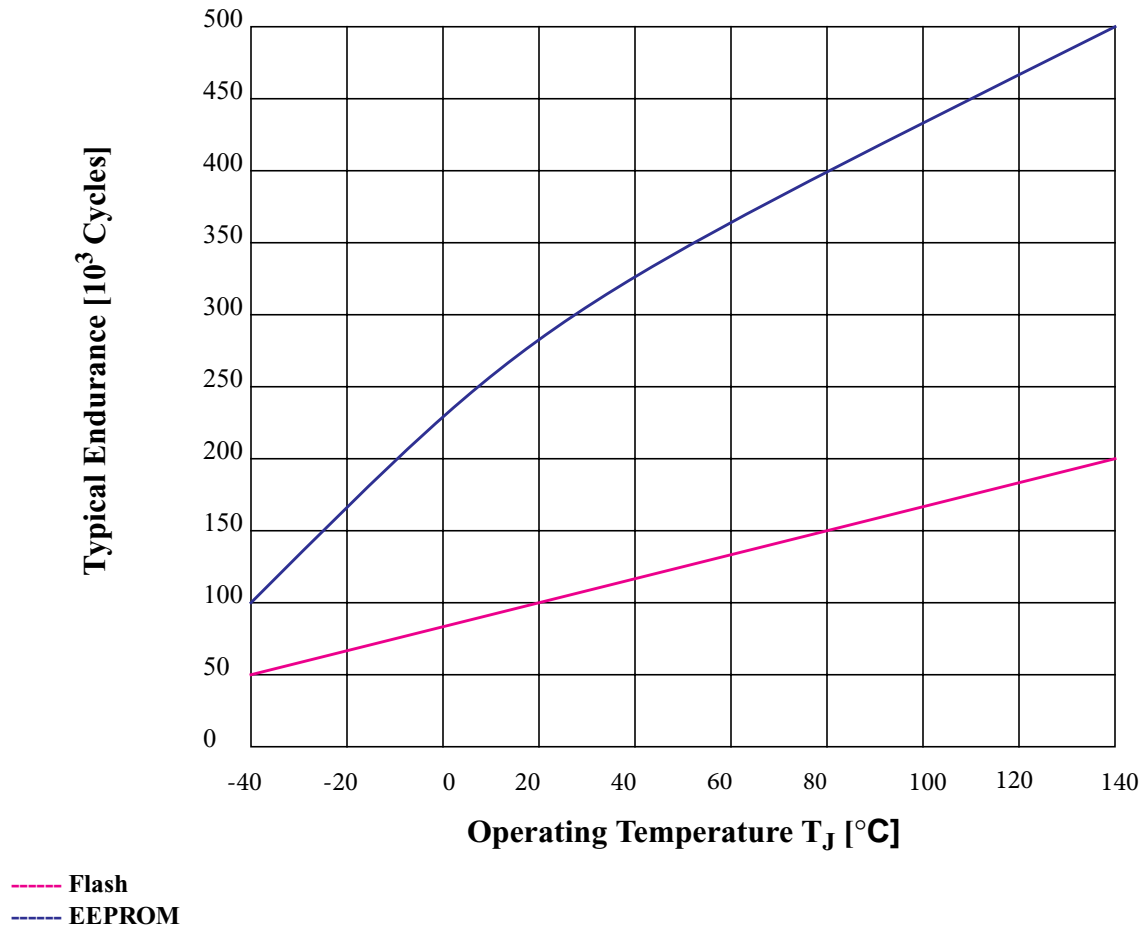

A.4 Voltage Regulator

The on-chip voltage regulator is intended to supply the internal logic and oscillator circuits. No external DC load is allowed.

Table A-13 Voltage Regulator Recommended Load Capacitances

Rating	Symbol	Min	Typ	Max	Unit
Load Capacitance on VDD1, 2	C_{LVDD}	-	220	-	nF
Load Capacitance on VDDPLL	$C_{LVDDfcPLL}$	-	220	-	nF



A.5 Reset, Oscillator and PLL

This section summarizes the electrical characteristics of the various startup scenarios for Oscillator and Phase-Locked-Loop (PLL).

A.5.1 Startup

Table A-14 summarizes several startup characteristics explained in this section. Detailed description of the startup behavior can be found in the Clock and Reset Generator (CRG) Block Guide.

Table A-14 Startup Characteristics

Conditions are shown in Table A-4 unless otherwise noted							
Num	C	Rating	Symbol	Min	Typ	Max	Unit
1	T	POR release level	V_{PORR}	-	-	2.07	V
2	T	POR assert level	V_{PORA}	0.97	-	-	V
3	D	Reset input pulse width, minimum input time	PW_{RSTL}	2	-	-	t_{osc}
4	D	Startup from Reset	n_{RST}	192	-	196	n_{osc}
5	D	Interrupt pulse width, \overline{IRQ} edge-sensitive mode	PW_{IRQ}	20	-	-	ns
6	D	Wait recovery startup time	t_{WRS}	-	-	14	t_{cyc}

A.5.1.1 POR

The release level V_{PORR} and the assert level V_{PORA} are derived from the V_{DD} Supply. They are also valid if the device is powered externally. After releasing the POR reset the oscillator and the clock quality check are started. If after a time t_{CQOUT} no valid oscillation is detected, the MCU will start using the internal self clock. The fastest startup time possible is given by n_{uposc} .

A.5.1.2 SRAM Data Retention

Provided an appropriate external reset signal is applied to the MCU, preventing the CPU from executing code when V_{DD5} is out of specification limits, the SRAM contents integrity is guaranteed if after the reset the PORF bit in the CRG Flags Register has not been set.

A.5.1.3 External Reset

When external reset is asserted for a time greater than PW_{RSTL} the CRG module generates an internal reset, and the CPU starts fetching the reset vector without doing a clock quality check, if there was an oscillation before reset.

A.5.1.4 Stop Recovery

Out of STOP the controller can be woken up by an external interrupt. A clock quality check as after POR is performed before releasing the clocks to the system.

A.5.1.5 Pseudo Stop and Wait Recovery

The recovery from Pseudo STOP and Wait are essentially the same since the oscillator was not stopped in both modes. The controller can be woken up by internal or external interrupts. After t_{WRS} the CPU starts fetching the interrupt vector.

A.5.2 Oscillator

The device features an internal Colpitts and Pierce oscillator. The selection of Colpitts oscillator or Pierce oscillator/external clock depends on the \overline{XCLKS} signal which is sampled during reset. Pierce oscillator/external clock mode allows the input of a square wave. Before asserting the oscillator to the internal system clocks the quality of the oscillation is checked for each start from either power-on, STOP or oscillator fail. t_{CQOUT} specifies the maximum time before switching to the internal self clock mode after POR or STOP if a proper oscillation is not detected. The quality check also determines the minimum oscillator start-up time t_{UPOSC} . The device also features a clock monitor. A Clock Monitor Failure is asserted if the frequency of the incoming clock signal is below the Assert Frequency f_{CMFA} .

Table A-15 Oscillator Characteristics

Conditions are shown in Table A-4 unless otherwise noted							
Num	C	Rating	Symbol	Min	Typ	Max	Unit
1a	C	Crystal oscillator range (Colpitts)	f_{OSC}	0.5	-	16	MHz
1b	C	Crystal oscillator range (Pierce) ¹	f_{OSC}	0.5	-	40	MHz
2	P	Startup Current	i_{OSC}	100	-	-	μA
3	C	Oscillator start-up time (Colpitts)	t_{UPOSC}	-	8^2	100^3	ms
4	D	Clock Quality check time-out	t_{CQOUT}	0.45	-	2.5	s
5	P	Clock Monitor Failure Assert Frequency	f_{CMFA}	50	100	200	KHz
6	P	External square wave input frequency ⁴	f_{EXT}	0.5	-	50	MHz
7	D	External square wave pulse width low ⁴	t_{EXTL}	9.5	-	-	ns
8	D	External square wave pulse width high ⁴	t_{EXTH}	9.5	-	-	ns
9	D	External square wave rise time ⁴	t_{EXTR}	-	-	1	ns
10	D	External square wave fall time ⁴	t_{EXTF}	-	-	1	ns
11	D	Input Capacitance (EXTAL, XTAL pins)	C_{IN}	-	7	-	pF
12	C	DC Operating Bias in Colpitts Configuration on EXTAL Pin	V_{DCBIAS}	-	1.1	-	V
13	P	EXTAL Pin Input High Voltage ⁴	$V_{IH,EXTAL}$	$0.75 \cdot V_{DDPLL}$	-	-	V
	T	EXTAL Pin Input High Voltage ⁴	$V_{IH,EXTAL}$	-	-	$V_{DDPLL} + 0.3$	V
14	P	EXTAL Pin Input Low Voltage ⁴	$V_{IL,EXTAL}$	-	-	$0.25 \cdot V_{SSPLL}$	V
	T	EXTAL Pin Input Low Voltage ⁴	$V_{IL,EXTAL}$	$V_{SSPLL} - 0.3$	-	-	V
15	C	EXTAL Pin Input Hysteresis ⁴	$V_{HYS,EXTAL}$	-	250	-	mV

NOTES:

1. Depending on the crystal a damping series resistor might be necessary
2. $f_{osc} = 4\text{MHz}$, $C = 22\text{pF}$.
3. Maximum value is for extreme cases using high Q, low frequency crystals
4. Only valid if Pierce oscillator/external clock mode is selected

A.5.3 Phase Locked Loop

The oscillator provides the reference clock for the PLL. The PLL's Voltage Controlled Oscillator (VCO) is also the system clock source in self clock mode.

A.5.3.1 XFC Component Selection

This section describes the selection of the XFC components to achieve a good filter characteristics.

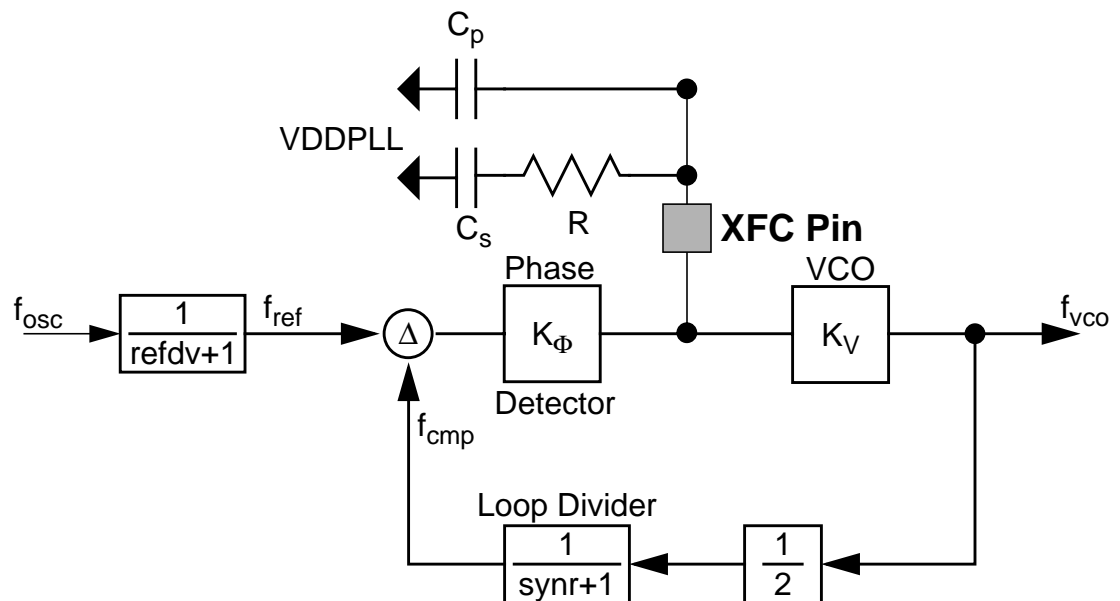

Figure A-3 Basic PLL functional diagram

The following procedure can be used to calculate the resistance and capacitance values using typical values for K_1 , f_1 and i_{ch} from **Table A-16**.

The grey boxes show the calculation for $f_{VCO} = 50\text{MHz}$ and $f_{ref} = 1\text{MHz}$. E.g., these frequencies are used for $f_{OSC} = 4\text{MHz}$ and a 25MHz bus clock.

The VCO Gain at the desired VCO frequency is approximated by:

$$K_V = K_1 \cdot e^{\frac{(f_1 - f_{VCO})}{K_1 \cdot 1V}} = -100 \cdot e^{\frac{(60 - 50)}{-100}} = -90.48\text{MHz/V}$$

The phase detector relationship is given by:

$$K_{\Phi} = -|i_{ch}| \cdot K_V = 316.7\text{Hz}/\Omega$$

i_{ch} is the current in tracking mode.

The loop bandwidth f_C should be chosen to fulfill the Gardner's stability criteria by at least a factor of 10, typical values are 50. $\zeta = 0.9$ ensures a good transient response.

$$f_C < \frac{2 \cdot \zeta \cdot f_{ref}}{\pi \cdot (\zeta + \sqrt{1 + \zeta^2})} \cdot \frac{1}{10} \rightarrow f_C < \frac{f_{ref}}{4 \cdot 10}; (\zeta = 0.9)$$

$$f_C < 25\text{kHz}$$

And finally the frequency relationship is defined as

$$n = \frac{f_{VCO}}{f_{ref}} = 2 \cdot (\text{synr} + 1) = 50$$

With the above values the resistance can be calculated. The example is shown for a loop bandwidth $f_C=10\text{kHz}$:

$$R = \frac{2 \cdot \pi \cdot n \cdot f_C}{K_{\Phi}} = 2 \cdot \pi \cdot 50 \cdot 10\text{kHz} / (316.7\text{Hz}/\Omega) = 9.9\text{k}\Omega \approx 10\text{k}\Omega$$

The capacitance C_s can now be calculated as:

$$C_s = \frac{2 \cdot \zeta^2}{\pi \cdot f_C \cdot R} \approx \frac{0.516}{f_C \cdot R}; (\zeta = 0.9) = 5.19\text{nF} \approx 4.7\text{nF}$$

The capacitance C_p should be chosen in the range of:

$$C_s/20 \leq C_p \leq C_s/10 \quad C_p = 470\text{pF}$$

A.5.3.2 Jitter Information

The basic functionality of the PLL is shown in **Figure A-3**. With each transition of the clock f_{cmp} , the deviation from the reference clock f_{ref} is measured and input voltage to the VCO is adjusted accordingly. The adjustment is done continuously with no abrupt changes in the clock output frequency. Noise, voltage, temperature and other factors cause slight variations in the control loop resulting in a clock jitter. This jitter affects the real minimum and maximum clock periods as illustrated in **Figure A-4**.

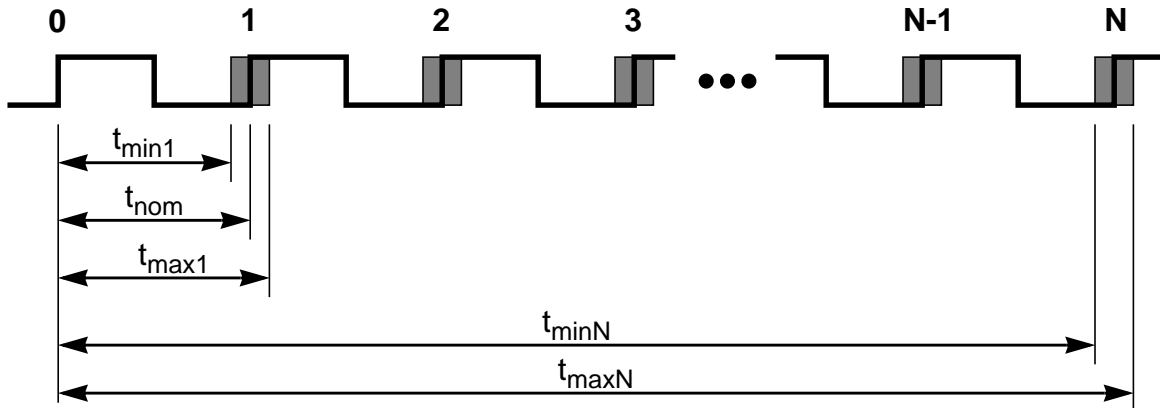

Figure A-4 Jitter Definitions

The relative deviation of t_{nom} is at its maximum for one clock period, and decreases towards zero for larger number of clock periods (N).

Defining the jitter as:

$$J(N) = \max\left(\left|1 - \frac{t_{\text{max}}(N)}{N \cdot t_{\text{nom}}}\right|, \left|1 - \frac{t_{\text{min}}(N)}{N \cdot t_{\text{nom}}}\right|\right)$$

For $N < 100$, the following equation is a good fit for the maximum jitter:

$$J(N) = \frac{j_1}{\sqrt{N}} + j_2$$

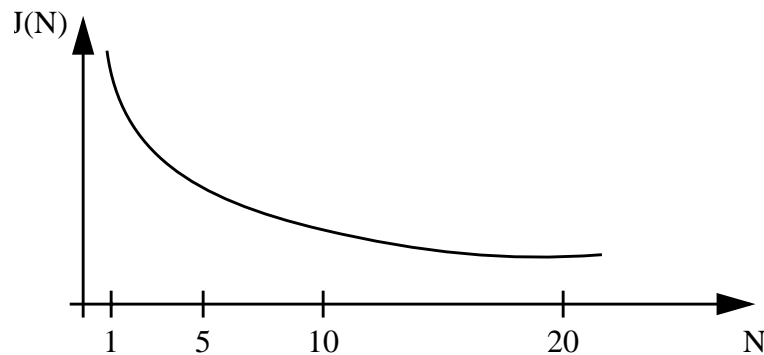

Figure A-5 Maximum bus clock jitter approximation

This is very important to notice with respect to timers, serial modules where a pre-scaler will eliminate the effect of the jitter to a large extent.

Table A-16 PLL Characteristics

Conditions are shown in Table A-4 unless otherwise noted							
Num	C	Rating	Symbol	Min	Typ	Max	Unit
1	P	Self Clock Mode frequency	f_{SCM}	1	-	5.5	MHz
2	D	VCO locking range	f_{VCO}	8	-	50	MHz
3	D	Lock Detector transition from Acquisition to Tracking mode	$ \Delta_{trk} $	3	-	4	% ¹
4	D	Lock Detection	$ \Delta_{Lock} $	0	-	1.5	% ⁽¹⁾
5	D	Un-Lock Detection	$ \Delta_{unt} $	0.5	-	2.5	% ⁽¹⁾
6	D	Lock Detector transition from Tracking to Acquisition mode	$ \Delta_{unt} $	6	-	8	% ⁽¹⁾
7	C	PLLON Total Stabilization delay (Auto Mode) ²	t_{stab}	-	0.5	-	ms
8	D	PLLON Acquisition mode stabilization delay ⁽²⁾	t_{acq}	-	0.3	-	ms
9	D	PLLON Tracking mode stabilization delay ⁽²⁾	t_{al}	-	0.2	-	ms
10	D	Fitting parameter VCO loop gain	K_1	-	-100	-	MHz/V
11	D	Fitting parameter VCO loop frequency	f_1	-	60	-	MHz
12	D	Charge pump current acquisition mode	$ i_{ch} $	-	38.5	-	μA
13	D	Charge pump current tracking mode	$ i_{ch} $	-	3.5	-	μA
14	C	Jitter fit parameter 1 ⁽²⁾	j_1	-	-	1.1	%
15	C	Jitter fit parameter 2 ⁽²⁾	j_2	-	-	0.13	%

NOTES:

1. % deviation from target frequency
2. $f_{OSC} = 4\text{MHz}$, $f_{BUS} = 25\text{MHz}$ equivalent $f_{VCO} = 50\text{MHz}$: REFDV = #03, SYNRR = #018, Cs = 4.7nF, Cp = 470pF, Rs = 10K Ω .

A.6 MSCAN

Table A-17 MSCAN Wake-up Pulse Characteristics

Conditions are shown in Table A-4 unless otherwise noted							
Num	C	Rating	Symbol	Min	Typ	Max	Unit
1	P	MSCAN Wake-up dominant pulse filtered	t_{WUP}	-	-	2	μs
2	P	MSCAN Wake-up dominant pulse pass	t_{WUP}	5	-	-	μs



A.7 SPI

This section provides electrical parametrics and ratings for the SPI.

In **Table A-18** the measurement conditions are listed.

Table A-18 Measurement Conditions

Description	Value	Unit
Drive mode	full drive mode	—
Load capacitance C_{LOAD} , on all outputs	50	pF
Thresholds for delay measurement points	(20% / 80%) V_{DDX}	V

A.7.1 Master Mode

In **Figure A-6** the timing diagram for master mode with transmission format $CPHA=0$ is depicted.

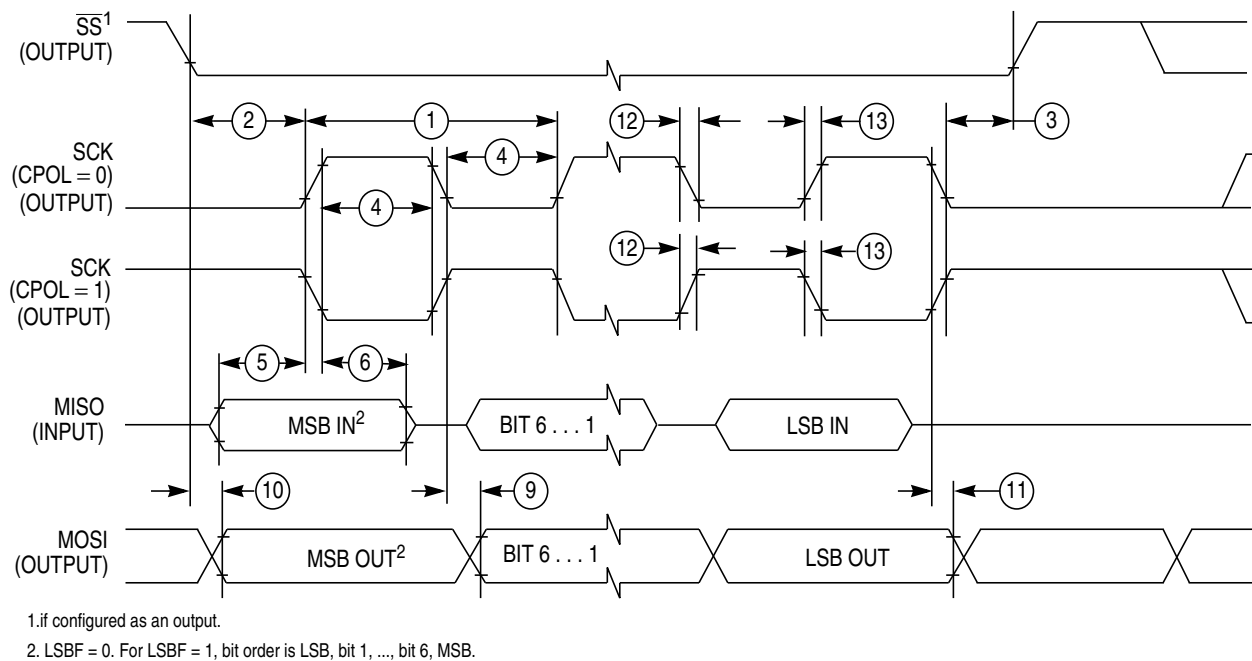
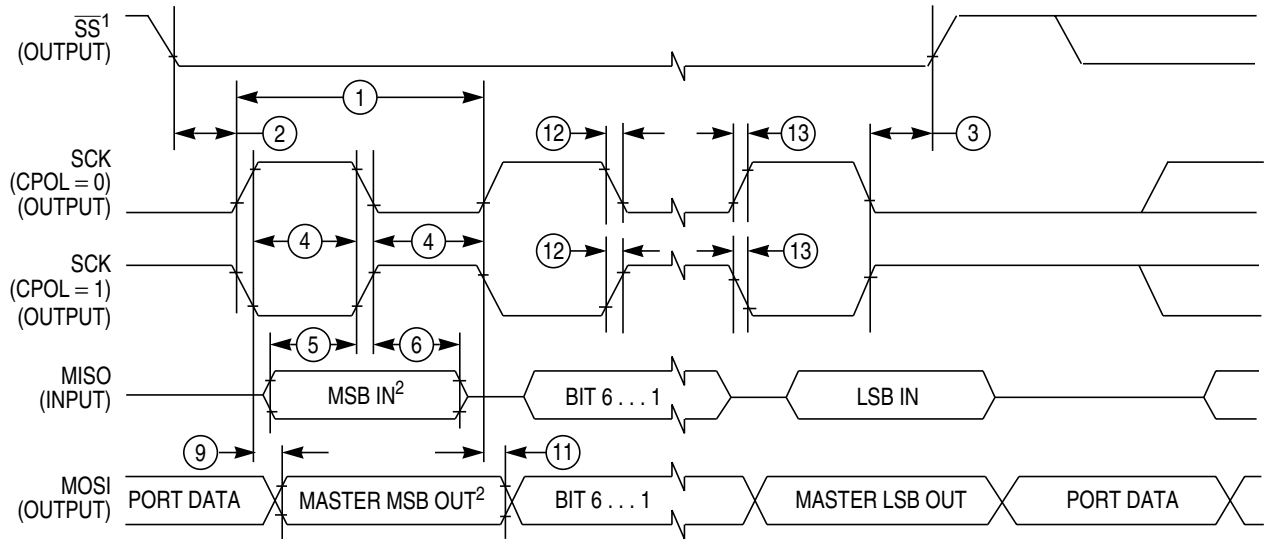

Figure A-6 SPI Master Timing (CPHA=0)

In **Figure A-7** the timing diagram for master mode with transmission format $CPHA=1$ is depicted.



1. If configured as output
 2. LSBF = 0. For LSBF = 1, bit order is LSB, bit 1, ..., bit 6, MSB.

Figure A-7 SPI Master Timing (CPHA=1)

In Table A-19 the timing characteristics for master mode are listed.

Table A-19 SPI Master Mode Timing Characteristics

Num	Characteristic	Symbol				Unit
			Min	Typ	Max	
1	SCK Frequency	f_{sck}	1/2048	—	1/2	f_{bus}
1	SCK Period	t_{sck}	2	—	2048	t_{bus}
2	Enable Lead Time	t_{lead}	—	1/2	—	t_{sck}
3	Enable Lag Time	t_{lag}	—	1/2	—	t_{sck}
4	Clock (SCK) High or Low Time	t_{wsck}	—	1/2	—	t_{sck}
5	Data Setup Time (Inputs)	t_{su}	8	—	—	ns
6	Data Hold Time (Inputs)	t_{hi}	8	—	—	ns
9	Data Valid after SCK Edge	t_{vsck}	—	—	30	ns
10	Data Valid after \overline{SS} fall (CPHA=0)	t_{vss}	—	—	15	ns
11	Data Hold Time (Outputs)	t_{ho}	20	—	—	ns
12	Rise and Fall Time Inputs	t_{rfi}	—	—	8	ns
13	Rise and Fall Time Outputs	t_{rfo}	—	—	8	ns

A.7.2 Slave Mode

In **Figure A-8** the timing diagram for slave mode with transmission format CPHA=0 is depicted.

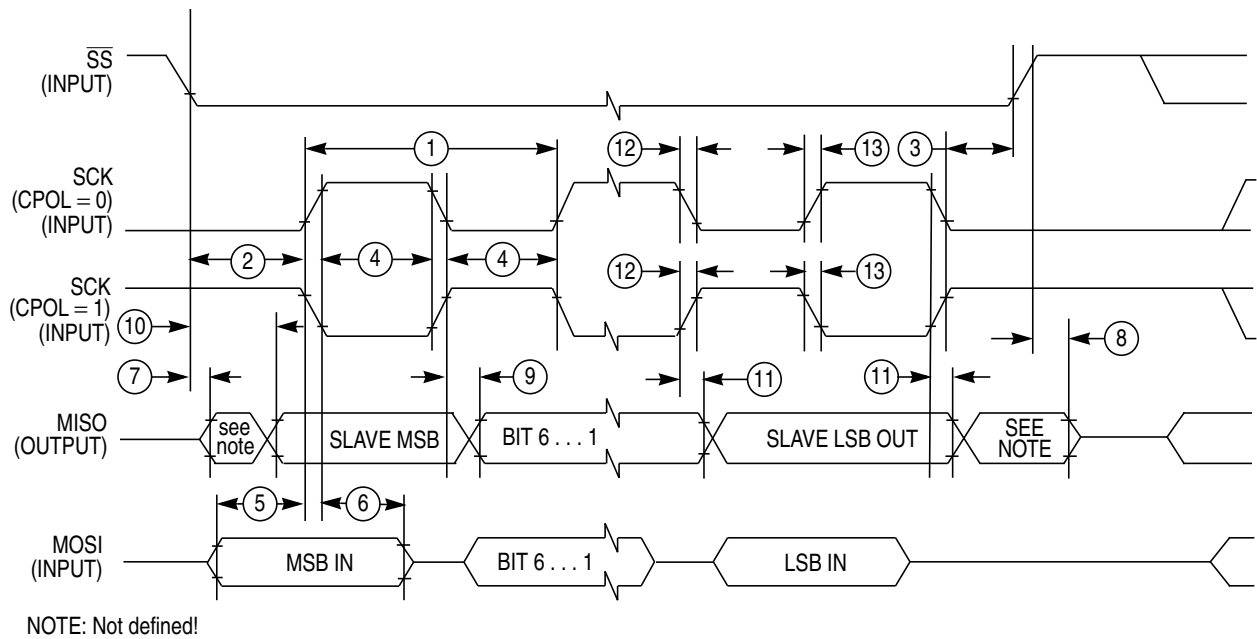

Figure A-8 SPI Slave Timing (CPHA=0)

In **Figure A-9** the timing diagram for slave mode with transmission format CPHA=1 is depicted.

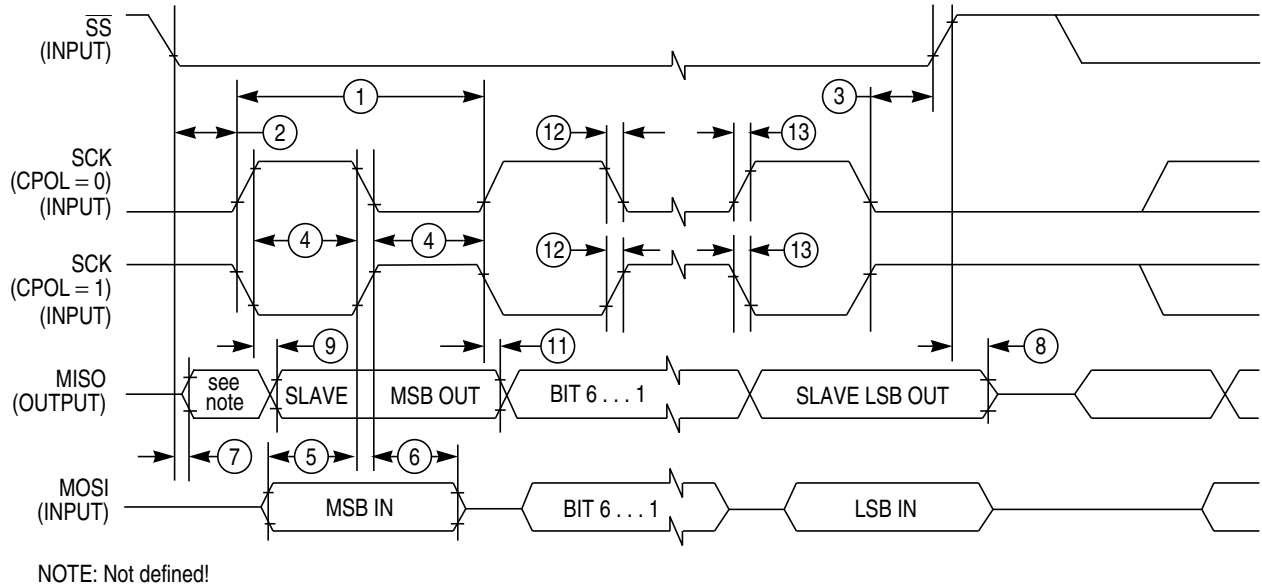

Figure A-9 SPI Slave Timing (CPHA=1)

In Table A-20 the timing characteristics for slave mode are listed.

Table A-20 SPI Slave Mode Timing Characteristics

Num	Characteristic	Symbol				Unit
			Min	Typ	Max	
1	SCK Frequency	f_{sck}	DC	—	1/4	f_{bus}
1	SCK Period	t_{sck}	4	—	∞	t_{bus}
2	Enable Lead Time	t_{lead}	4	—	—	t_{bus}
3	Enable Lag Time	t_{lag}	4	—	—	t_{bus}
4	Clock (SCK) High or Low Time	t_{wsck}	4	—	—	t_{bus}
5	Data Setup Time (Inputs)	t_{su}	8	—	—	ns
6	Data Hold Time (Inputs)	t_{hi}	8	—	—	ns
7	Slave Access Time (time to data active)	t_a	—	—	20	ns
8	Slave MISO Disable Time	t_{dis}	—	—	22	ns
9	Data Valid after SCK Edge	t_{vsck}	—	—	$30 + t_{bus}^1$	ns
10	Data Valid after SS fall	t_{vss}	—	—	$30 + t_{bus}^1$	ns
11	Data Hold Time (Outputs)	t_{ho}	20	—	—	ns
12	Rise and Fall Time Inputs	t_{rfi}	—	—	8	ns
13	Rise and Fall Time Outputs	t_{rfo}	—	—	8	ns

NOTES:

- 1. t_{bus} added due to internal synchronization delay

A.8 External Bus Timing

A timing diagram of the external multiplexed-bus is illustrated in **Figure A-10** with the actual timing values shown on table **Table A-21**. All major bus signals are included in the diagram. While both a data write and data read cycle are shown, only one or the other would occur on a particular bus cycle.

A.8.1 General Muxed Bus Timing

The expanded bus timings are highly dependent on the load conditions. The timing parameters shown assume a balanced load across all outputs.

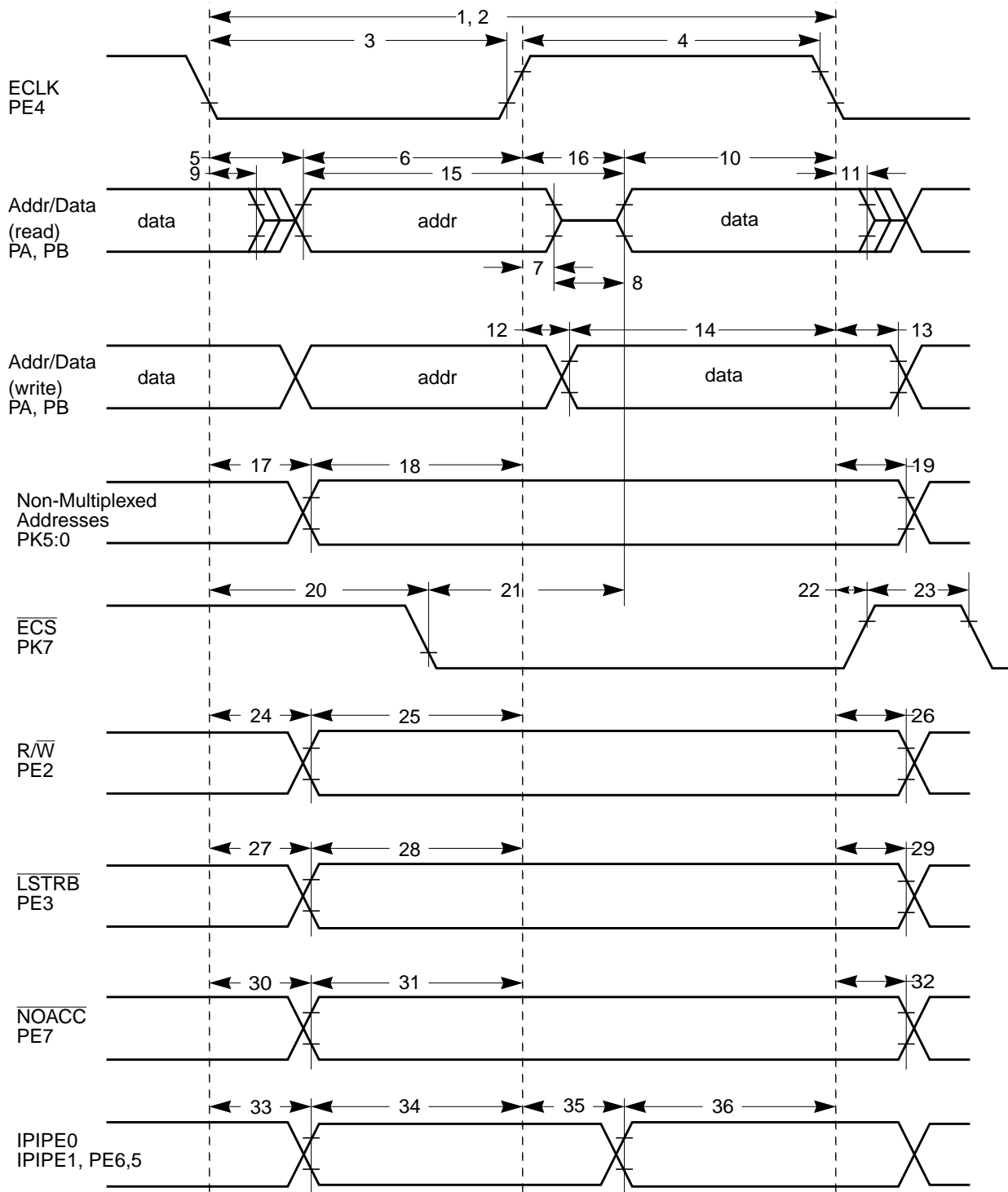

Figure A-10 General External Bus Timing

Table A-21 Expanded Bus Timing Characteristics

Conditions are shown in Table A-4 unless otherwise noted, $C_{LOAD} = 50\text{pF}$							
Num	C	Rating	Symbol	Min	Typ	Max	Unit
1	P	Frequency of operation (E-clock)	f_o	0	-	25.0	MHz
2	P	Cycle time	t_{cyc}	40	-	-	ns
3	D	Pulse width, E low	PW_{EL}	19	-	-	ns
4	D	Pulse width, E high ¹	PW_{EH}	19	-	-	ns
5	D	Address delay time	t_{AD}	-	-	8	ns
6	D	Address valid time to E rise ($PW_{EL}-t_{AD}$)	t_{AV}	11	-	-	ns
7	D	Muxed address hold time	t_{MAH}	2	-	-	ns
8	D	Address hold to data valid	t_{AHDS}	7	-	-	ns
9	D	Data hold to address	t_{DHA}	2	-	-	ns
10	D	Read data setup time	t_{DSR}	13	-	-	ns
11	D	Read data hold time	t_{DHR}	0	-	-	ns
12	D	Write data delay time	t_{DDW}	-	-	7	ns
13	D	Write data hold time	t_{DHW}	2	-	-	ns
14	D	Write data setup time ⁽¹⁾ ($PW_{EH}-t_{DDW}$)	t_{DSW}	12	-	-	ns
15	D	Address access time ⁽¹⁾ ($t_{cyc}-t_{AD}-t_{DSR}$)	t_{ACCA}	19	-	-	ns
16	D	E high access time ⁽¹⁾ ($PW_{EH}-t_{DSR}$)	t_{ACCE}	6	-	-	ns
17	D	Non-multiplexed address delay time	t_{NAD}	-	-	6	ns
18	D	Non-muxed address valid to E rise ($PW_{EL}-t_{NAD}$)	t_{NAV}	13	-	-	ns
19	D	Non-multiplexed address hold time	t_{NAH}	2	-	-	ns
20	D	Chip select delay time	t_{CSD}	-	-	16	ns
21	D	Chip select access time ⁽¹⁾ ($t_{cyc}-t_{CSD}-t_{DSR}$)	t_{ACCS}	11	-	-	ns
22	D	Chip select hold time	t_{CSH}	2	-	-	ns
23	D	Chip select negated time	t_{CSN}	8	-	-	ns
24	D	Read/write delay time	t_{RWD}	-	-	7	ns
25	D	Read/write valid time to E rise ($PW_{EL}-t_{RWD}$)	t_{RWV}	14	-	-	ns
26	D	Read/write hold time	t_{RWH}	2	-	-	ns
27	D	Low strobe delay time	t_{LSD}	-	-	7	ns
28	D	Low strobe valid time to E rise ($PW_{EL}-t_{LSD}$)	t_{LSV}	14	-	-	ns
29	D	Low strobe hold time	t_{LSH}	2	-	-	ns
30	D	NOACC strobe delay time	t_{NOD}	-	-	7	ns
31	D	NOACC valid time to E rise ($PW_{EL}-t_{NOD}$)	t_{NOV}	14	-	-	ns

Table A-21 Expanded Bus Timing Characteristics

Conditions are shown in Table A-4 unless otherwise noted, $C_{LOAD} = 50pF$							
Num	C	Rating	Symbol	Min	Typ	Max	Unit
32	D	NOACC hold time	t_{NOH}	2	-	-	ns
33	D	IPIPE[1:0] delay time	t_{P0D}	2	-	7	ns
34	D	IPIPE[1:0] valid time to E rise ($PW_{EL} - t_{P0D}$)	t_{P0V}	11	-	-	ns
35	D	IPIPE[1:0] delay time ⁽¹⁾ ($PW_{EH} - t_{P1V}$)	t_{P1D}	2	-	7	ns
36	D	IPIPE[1:0] valid time to E fall	t_{P1V}	11	-	-	ns

NOTES:

1. Affected by clock stretch: add $N \times t_{cyc}$ where $N=0,1,2$ or 3 , depending on the number of clock stretches.

Appendix B Package Information

B.1 General

This section provides the physical dimensions of the MC9S12DP512 packages.

B.2 112-pin LQFP package

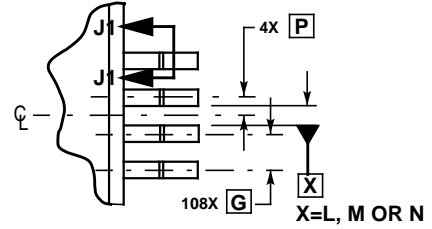
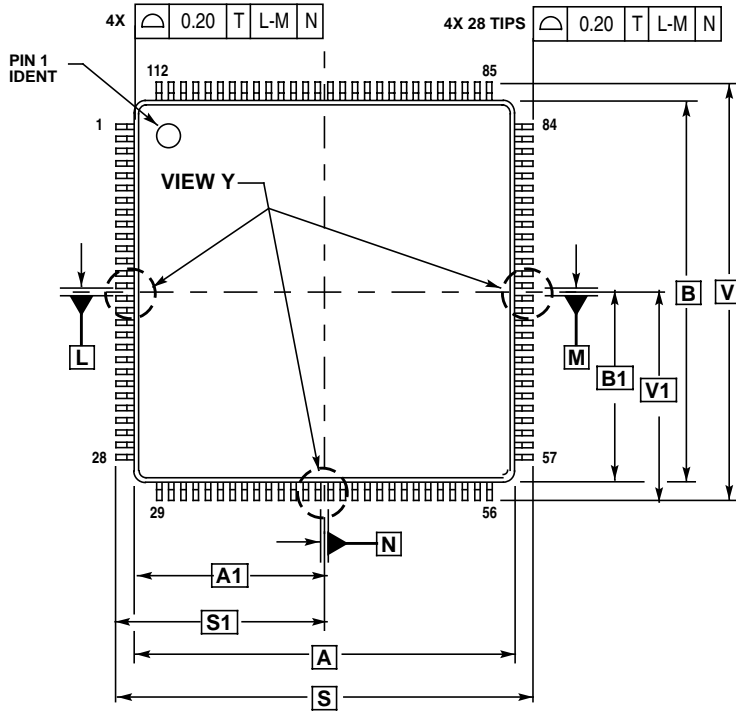

VIEW Y

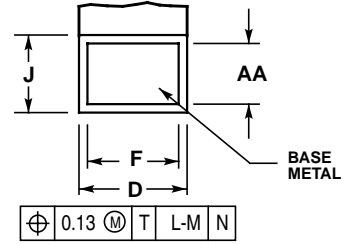

NOTES:

1. DIMENSIONING AND TOLERANCING PER ASME Y14.5M, 1994.
2. DIMENSIONS IN MILLIMETERS.
3. DATUMS L, M AND N TO BE DETERMINED AT SEATING PLANE, DATUM T.
4. DIMENSIONS S AND V TO BE DETERMINED AT SEATING PLANE, DATUM T.
5. DIMENSIONS A AND B DO NOT INCLUDE MOLD PROTRUSION. ALLOWABLE PROTRUSION IS 0.25 PER SIDE. DIMENSIONS A AND B INCLUDE MOLD MISMATCH.
6. DIMENSION D DOES NOT INCLUDE DAMBAR PROTRUSION. ALLOWABLE DAMBAR PROTRUSION SHALL NOT CAUSE THE D DIMENSION TO EXCEED 0.46.

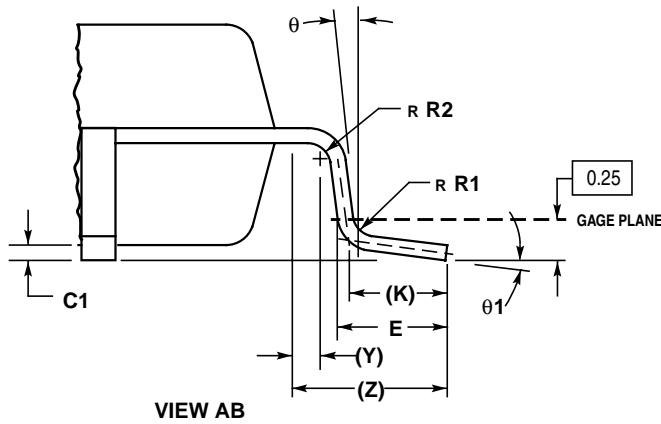
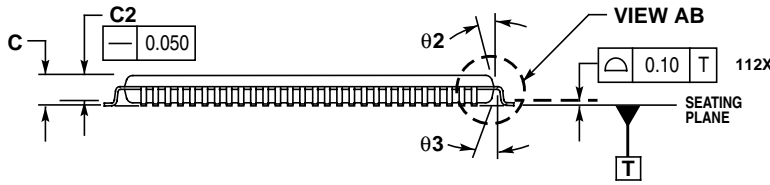

DIM	MILLIMETERS	
	MIN	MAX
A	20.000	BSC
A1	10.000	BSC
B	20.000	BSC
B1	10.000	BSC
C	---	1.600
C1	0.050	0.150
C2	1.350	1.450
D	0.270	0.370
E	0.450	0.750
F	0.270	0.330
G	0.650	BSC
J	0.090	0.170
K	0.500	REF
P	0.325	BSC
R1	0.100	0.200
R2	0.100	0.200
S	22.000	BSC
S1	11.000	BSC
V	22.000	BSC
V1	11.000	BSC
Y	0.250	REF
Z	1.000	REF
AA	0.090	0.160
θ	0°	8°
$\theta 1$	3°	7°
$\theta 2$	11°	13°
$\theta 3$	11°	13°

Figure B-1 112-pin LQFP mechanical dimensions (case no. 987)

User Guide End Sheet

