

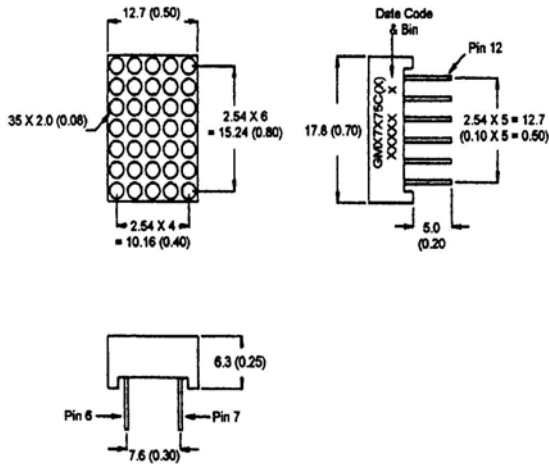

0.7 INCH (17.2mm) 5 X 7 DOT MATRIX STICK DISPLAY

Superbright Red GMX7275C
Superbright Red GMX7275CA

PACKAGE DIMENSIONS



NOTE: Dimensions are in mm (inch).
Tolerances are ± 0.25 (0.1) unless otherwise noted.
All pins are 0.6 (.02).

DESCRIPTION

The GMX7275C(X) is a 5 X 7, Superbright red dotmatrix display. Populated with GaAlAs/GaAs Single Hetero Junction LEDs, it has a grey face with white segment color.

FEATURES

- 0.7" (17.2mm) character height.
- Low power requirement.
- Wide 130° viewing angle.
- High brightness and contrast
- 5 X 7 array with X-Y select.
- X-Y stackable.
- Easy mounting on P.C. board.

MODEL NUMBERS

<u>Part Number</u>	<u>Colour</u>	<u>Description</u>
GMA7275C	AlGaAs Red	Common anode row.
GMA7275CA	AlGaAs Red	Common anode row, alternate pin-out.
GMC7275C	AlGaAs Red	Common cathode row.
GMC7275CA	AlGaAs Red	Common cathode row, alternate pin-out.

(For other color options, contact your local area Sales Office)



0.7 INCH (17.2mm) 5 X 7 DOT MATRIX STICK DISPLAY

ABSOLUTE MAXIMUM RATING ($T_A = 25^\circ\text{C}$ unless otherwise specified)

	Superbright Red	Units
Peak forward current per segment (Duty cycle 1/10, 10KHz)	200	mA
Continuous IF per segment	30	mA
Power dissipation per segment	100*	mW
*Derate linearly from 25°C	0.5	mW/°C
Reverse voltage V_R per segment	5	Volts
Operating and storage temperature range.....	-25°C to +85°C	
Soldering time at 260°C..... (1/16" below seating plane)	3 sec	

ELECTRO - OPTICAL CHARACTERISTICS ($T_A = 25^\circ\text{C}$ unless otherwise specified)

	Superbright Red	Test Condition
Luminous Intensity/Dot Digit average (Typical)	5000ucd	$I_F = 20 \text{ mA}$
Forward voltage (V_F) typical	1.8V	$I_F = 20 \text{ mA}$
maximum	2.5V	$I_F = 20 \text{ mA}$
Peak wavelength (nm)	660nm	$I_F = 20 \text{ mA}$
Spectral line half width (nm)	20nm	$I_F = 20 \text{ mA}$
Reverse breakdown voltage V_R	5V	$I_R = 100 \mu\text{A}$



**0.7 INCH (17.2mm) 5 X 7
DOT MATRIX STICK DISPLAY**

PIN CONNECTION:

GMX7X75C

GMA7X75C		GMC7X75C	
Pin Number	Function	Pin Number	Function
1	Anode Row 1	1	Cathode Row 1
2	Anode Row 2	2	Cathode Row 2
3	Cathode Column 2	3	Anode Column 2
4	Cathode Column 1	4	Anode Column 1
5	Anode Row 6	5	Cathode Row 6
6	Anode Row 7	6	Cathode Row 7
7	Cathode Column 3	7	Anode Column 3
8	Anode Row 5	8	Cathode Row 5
9	Cathode Column 4	9	Anode Column 4
10	Anode Row 4	10	Cathode Row 4
11	Anode Row 3	11	Cathode Row 3
12	Cathode Column 5	12	Anode Column 5

GMX7X75CA

GMC7X75CA		GMA7X75CA	
Pin Number	Function	Pin Number	Function
1	Anode Column 1	1	Cathode Column 1
2	Cathode Row 3	2	Anode Row 3
3	Anode Column 2	3	Cathode Column 2
4	Cathode Row 5	4	Anode Row 5
5	Cathode Row 6	5	Anode Row 6
6	Cathode Row 7	6	Anode Row 7
7	Anode Column 4	7	Cathode Column 3
8	Anode Column 5	8	Cathode Column 5
9	Cathode Row 4	9	Anode Row 4
10	Anode Column 3	10	Cathode Column 3
11	Cathode Row 2	11	Anode Row 2
12	Cathode Row 1	12	Anode Row 1



0.7 INCH (17.2mm) 5 X 7 DOT MATRIX STICK DISPLAY

SCHEMATICS:

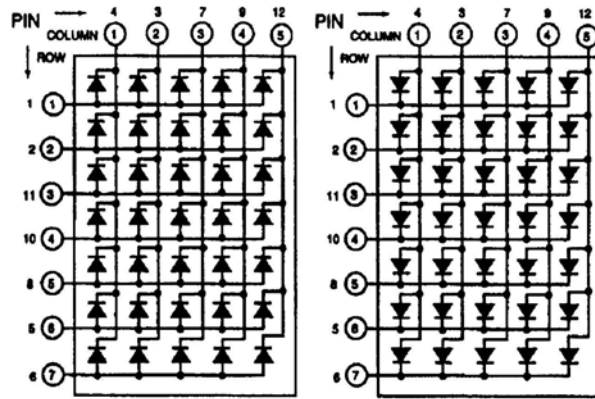

GMA7X75C

GMC7X75C

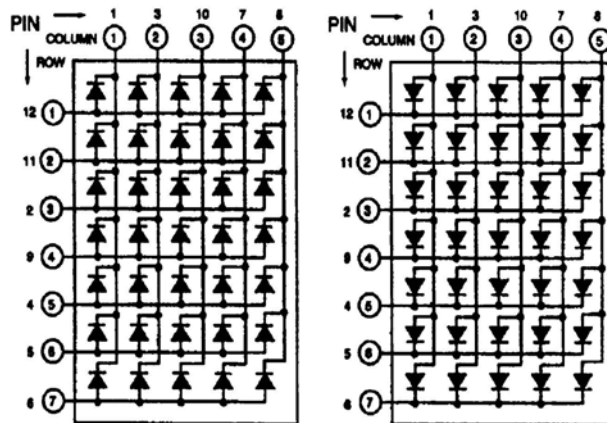

GMA7X75CA

GMC7X75CA



0.7 INCH (17.2mm) 5 X 7 DOT MATRIX STICK DISPLAY

GRAPHICAL DETAIL: AlGaAs Red ($T_A = 25^\circ\text{C}$ unless otherwise specified)

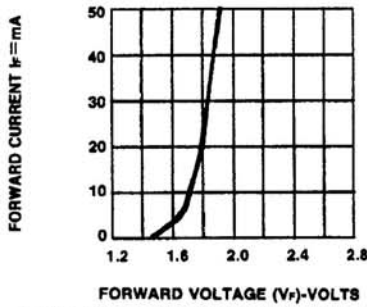

Fig.1 FORWARD CURRENT VS. FORWARD VOLTAGE.

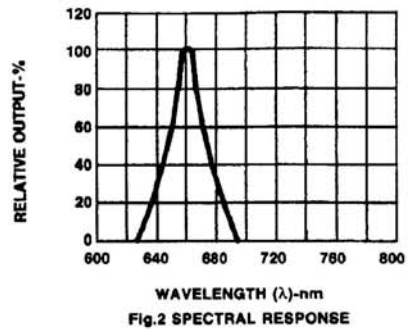

Fig.2 SPECTRAL RESPONSE

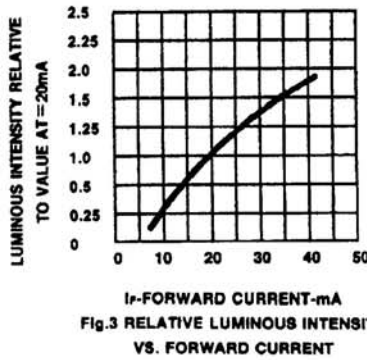

Fig.3 RELATIVE LUMINOUS INTENSITY VS. FORWARD CURRENT

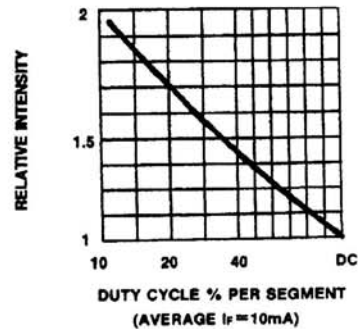

Fig.5 LUMINOUS INTENSITY VS. DUTY CYCLE

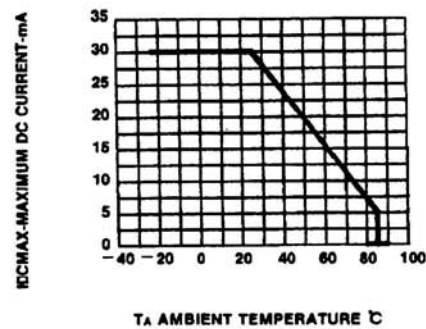

Fig.4 MAXIMUM ALLOWABLE DC CURRENT PER SEGMENT VS. A FUNCTION OF AMBIENT TEMPERATURE.

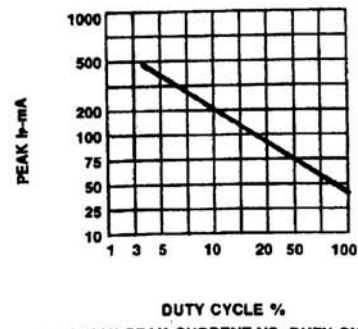

Fig.6 MAX PEAK CURRENT VS. DUTY CYCLE % (REFRESH RATE $f = 1 \text{ KHz}$)



0.7 INCH (17.2mm) 5 X 7 DOT MATRIX STICK DISPLAY

DISCLAIMER

FAIRCHILD SEMICONDUCTOR RESERVES THE RIGHT TO MAKE CHANGES WITHOUT FURTHER NOTICE TO ANY PRODUCTS HEREIN TO IMPROVE RELIABILITY, FUNCTION OR DESIGN. FAIRCHILD DOES NOT ASSUME ANY LIABILITY ARISING OUT OF THE APPLICATION OR USE OF ANY PRODUCT OR CIRCUIT DESCRIBED HEREIN; NEITHER DOES IT CONVEY ANY LICENSE UNDER ITS PATENT RIGHTS, NOR THE RIGHTS OF OTHERS.

LIFE SUPPORT POLICY

FAIRCHILD'S PRODUCTS ARE NOT AUTHORIZED FOR USE AS CRITICAL COMPONENTS IN LIFE SUPPORT DEVICES OR SYSTEMS WITHOUT THE EXPRESS WRITTEN APPROVAL OF THE PRESIDENT OF FAIRCHILD SEMICONDUCTOR CORPORATION. As used herein:

1. Life support devices or systems are devices or systems which, (a) are intended for surgical implant into the body, or (b) support or sustain life, and (c) whose failure to perform when properly used in accordance with instructions for use provided in the labeling, can be reasonably expected to result in a significant injury of the user.
2. A critical component in any component of a life support device or system whose failure to perform can be reasonably expected to cause the failure of the life support device or system, or to affect its safety or effectiveness.