

DESCRIPTION

The LXM1623-12-4x is a Dual 4W Output Direct Drive™ CCFL (Cold Cathode Fluorescent Lamp) Inverter Module specifically designed for driving LCD backlight lamps. It is ideal for driving typical 6.4" to 10.4" TFT panels.

LXM1623 modules provide the designer with a vastly superior display brightness range. This brightness range is achievable with virtually any LCD display.

The modules are available with a dimming input that permits brightness control from either a DC voltage source or a PWM signal or external Potentiometer. The maximum output current is externally programmable over a range of 5 to 6.5mA in 0.5mA steps to allow the inverter to properly match to a wide array of LCD panel lamp current specifications.

RangeMAX Digital Dimming Technique provides flicker-free brightness control in any wide range typically (50:1+) dimming application.

The resultant "burst drive" that energizes the lamp was designed specifically to ensure that no premature lamp degradation occurs, while allowing significant power savings at lower dim levels.

The modules convert DC voltage from the system battery or AC adapter directly to high frequency, high-voltage waves required to ignite and operate CCFL lamps. A 5V input inverter also is available (LXM1623-05-4x), as well as 6W versions (LXM1623-xx-6x) for driving larger higher voltage panels.

The modules design is based on Microsemi's new LX1689 backlight controller, which provides a number of cost and performance advantages due to the controller's high level of integration.

Other benefits of this new topology are stable fixed-frequency operation, secondary-side strike-voltage regulation and both open/shorted lamp protection with fault timeout.

KEY FEATURES

- Externally Programmable Maximum Output Current
- Easy to Use Brightness Control
- RangeMAX Wide Range Dimming
- Output Open & Short-Circuit Protection and Automatic Strike-Voltage Regulation and Timeout
- Fixed Frequency Operation
- Rated From -20 to 70°C
- UL60950 E175910

APPLICATIONS

- High Brightness Displays
- Portable Instrumentation
- Desktop Displays
- Industrial Display Controls

BENEFITS

- Smooth, Flicker Free 2%-100% Full-Range Brightness Control
- Programmable output current allows inverter to mate with a wide variety of LCD panel's specifications
- Output Open Circuit Voltage Regulation Minimizes Corona Discharge For High Reliability

IMPORTANT: For the most current data, consult MICROSEMI's website: <http://www.microsemi.com>
 Protected By U.S. Patents: 5,923,129; 5,930,121; 6,198, 234; Patents Pending

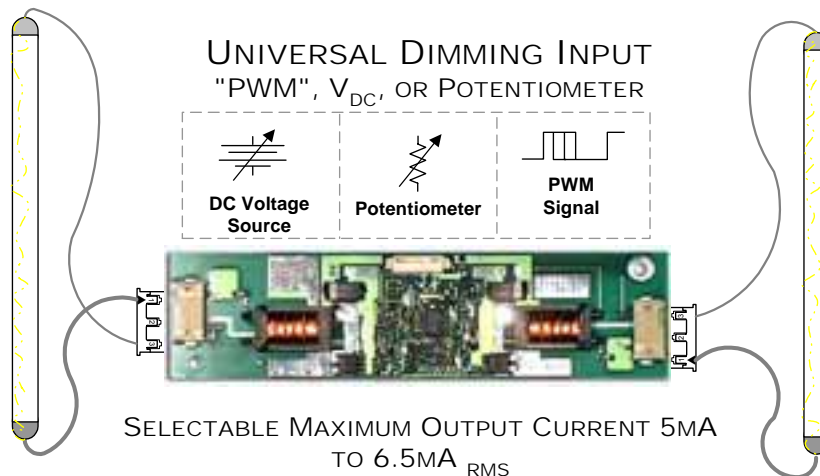
PRODUCT HIGHLIGHT

PACKAGE ORDER INFO

PART NUMBER	OUTPUT CONNECTOR	INVERTER MATES DIRECTLY TO PANEL CONNECTORS
LXM1623-12-41	JST SM02(8.0)B-BHS-1-TB or Yeon Ho 20015WR-05A00	JST BHR-03VS-1
LXM1623-12-42	JST SM02B-BHSS-1-TB or Yeon Ho 35001WR-02A00	JST BHSR-02VS-1
LXM1623-12-43	Honda QZ-19-A3MYL #02	Honda QZ-19-3F01



Microsemi
INTEGRATED PRODUCTS

PanelMatch™

LXM1623-12-4x

12V Dual 4W CCFL Programmable Inverter Module

PRODUCTION DATASHEET

www.Microsemi.com

ABSOLUTE MAXIMUM RATINGS (NOTE 1)

Input Signal Voltage (V_{IN1}).....	-0.3V to 15V
Input Power	10W
Output Voltage, no load	Internally Limited to $1500V_{RMS}$
Output Current	$7.5mA_{RMS}$ (Internally Limited)
Output Power (each output)	4.0W
Input Signal Voltage (SLEEP Input).....	-0.3V to V_{IN1}
Input Signal Voltage (BRITE)	-0.3V to 5.5V
Ambient Operating Temperature, zero airflow.....	-20°C to 70°C
Operating Relative Humidity, non-condensing	≤90%
Storage Temperature Range.....	-40°C to 85°C

Note 1: Exceeding these ratings could cause damage to the device. All voltages are with respect to Ground. Currents are positive into, negative out of specified terminal.

RECOMMENDED OPERATING CONDITIONS (R.C.)

This module has been designed to operate over a wide range of input and output conditions. However, best efficiency and performance will be obtained if the module is operated under the condition listed in the 'R.C.' column. Min. and Max. columns indicate values beyond which the inverter, although operational, will not function optimally.

Parameter	Symbol	Recommended Operating Conditions			Units
		Min	R.C.	Max	
Input Supply Voltage Range (Fully Regulated Lamp Current)	V_{IN1}	10.8	12	13.2	V
Input Supply Voltage Range (Functional)		10.2	12	13.8	
Output Power (each output)	P_O		3.5	4.0	W
Linear BRITE Control Input Voltage Range	V_{BRT_ADJ}	0.5		2.0	V
Lamp Operating Voltage	V_{LAMP}	350	440	530	V_{RMS}
Lamp Current (Full Brightness)	I_{OLAMP}	5		6.5	mA_{RMS}
Operating Ambient Temperature Range	T_A	-20		70	°C

ELECTRICAL CHARACTERISTICS

Unless otherwise specified, the following specifications apply over the recommended operating condition and ambient temperature of 25°C except where otherwise noted.

Parameter	Symbol	Test Conditions	LXM1623-12-4x			Units
			Min	Typ	Max	
OUTPUT PIN CHARACTERISTICS						
Full Bright Lamp Current (each output)	$I_{L(MAX)}$	$V_{BRT_ADJ} \geq 2.0V_{DC}$, $\overline{SLEEP} \geq 2.0V$, $V_{IN1} = 12V_{DC}$ $I_{SET1} = \text{Ground}$, $I_{SET2} = \text{Ground}$	4.5	5	5.5	mA_{RMS}
Full Bright Lamp Current (each output)	$I_{L(MAX)}$	$V_{BRT_ADJ} \geq 2.0V_{DC}$, $\overline{SLEEP} \geq 2.0V$, $V_{IN1} = 12V_{DC}$ $I_{SET1} = \text{Ground}$, $I_{SET2} = \text{Open}$	5.0	5.5	6.0	mA_{RMS}
Full Bright Lamp Current (each output)	$I_{L(MAX)}$	$V_{BRT_ADJ} \geq 2.0V_{DC}$, $\overline{SLEEP} \geq 2.0V$, $V_{IN1} = 12V_{DC}$ $I_{SET1} = \text{Open}$, $I_{SET2} = \text{Ground}$	5.5	6	6.5	mA_{RMS}
Full Bright Lamp Current (each output)	$I_{L(MAX)}$	$V_{BRT_ADJ} \geq 2.0V_{DC}$, $\overline{SLEEP} \geq 2.0V$, $V_{IN1} = 12V_{DC}$ $I_{SET1} = \text{Open}$, $I_{SET2} = \text{Open}$	6.0	6.5	7.0	mA_{RMS}
Output Current Lamp to Lamp Deviation	$I_{LL\%DEV}$	$V_{BRT_ADJ} \geq 2.0V_{DC}$, $\overline{SLEEP} \geq 2.0V$, $V_{IN1} = 12V_{DC}$ $I_{SET1} = \text{Open}$, $I_{SET2} = \text{Open}$		3	10	%
Min. Average Lamp Current (each output)	$I_{L(MIN)}$	$V_{BRT_ADJ} \leq 0.5V_{DC}$, $\overline{SLEEP} \geq 2.0V$, $V_{IN1} = 12V_{DC}$ $I_{SET1} = I_{SET2} = \text{Ground}$		0.30		mA_{RMS}
Lamp Start Voltage	V_{LS}	$-20^\circ\text{C} < T_A < 70^\circ\text{C}$, $V_{IN1} > 10.8V_{DC}$	1250	1400		V_{RMS}
Operating Frequency	f_O	$V_{BRT_ADJ} = 2.5V_{DC}$, $\overline{SLEEP} \geq 2.0V$, $V_{IN1} = 12V$	76	80	83	kHz
Burst Frequency	f_{BURST}	Output Burst Frequency	148	156	163	Hz

ELECTRICAL CHARACTERISTICS (CONTINUED)

Unless otherwise specified, the following specifications apply over the recommended operating condition and ambient temperature of 25°C except where otherwise noted.

Parameter	Symbol	Test Conditions	LXM1623-12-4x			Units
			Min	Typ	Max	
BRITE INPUT						
Input Current	I_{BRT}	$V_{BRT_ADJ} = 0V_{DC}$		-300		μA_{DC}
		$V_{BRT_ADJ} = 3V_{DC}$		50		μA_{DC}
Minimum Input for Max. Lamp Current	V_{BRT_ADJ}	$I_{O(LAMP)} = \text{Maximum Lamp Current}$		2.0	2.05	V_{DC}
Maximum Input for Min. Lamp Current	V_{BRT_ADJ}	$I_{O(LAMP)} = \text{Minimum Lamp Current}$	0.4	0.5		V_{DC}
SLEEP INPUT						
RUN Mode	V_{SLEEP}		2.0		V_{IN1}	V_{DC}
SLEEP Mode	V_{SLEEP}		-0.3		0.8	V_{DC}
SET_{1,2} INPUT						
SET _{1,2} Low Threshold	V_L				0.4	V
Input Current	I_{SET}	$V_{SET} \leq 0.4V$		-300		μA
POWER CHARACTERISTICS						
Sleep Current	$I_{IN(MIN)}$	$V_{IN1} = 12V_{DC}, \overline{SLEEP} \leq 0.8V$	0.0	10	50	μA_{DC}
Run Current	$I_{IN(RUN)}$	$V_{IN1} = 12V_{DC}, \overline{SLEEP} \geq 2.0V, I_{SET1} = \text{Open}$ $I_{SET2} = \text{Ground}, V_{LAMP} = 440V_{RMS}$		530		mA_{DC}
Efficiency	η	$V_{IN1} = 12V_{DC}, \overline{SLEEP} \geq 2.0V, I_{SET1} = \text{Open}$ $I_{SET2} = \text{Ground}, V_{LAMP} = 440V_{RMS}$		85		%

FUNCTIONAL PIN DESCRIPTION

CONN	PIN	DESCRIPTION
CN1 (Molex 53261-0890) Mates with 51021-0800 housing, 50079-8100 pins. Mates with LX9501 input cable assembly		
CN1-1	V_{IN1}	Main Input Power Supply ($10.8V \leq V_{IN1} \leq 13.2V$)
CN1-2		
CN1-3	GND	Power Supply Return
CN1-4		
CN1-5	\overline{SLEEP}	ON/OFF Control. ($0V < \overline{SLEEP} < 0.8 = \text{OFF}, \overline{SLEEP} \geq 2.0V = \text{ON}$)
CN1-6	BRITE	Brightness Control ($0.5V$ to $2.0V_{DC}$). $2.0V_{DC}$ gives maximum lamp current.
CN1-7	SET ₁	SET ₁ MSB Connecting this pin to ground decreases the output current (see Table 1)
CN1-8	SET ₂	SET ₂ LSB Connecting this pin to ground decreases the output current (see Table 1)
CN2, CN3 for LXM1623-12-41 and -42 (JST SM02(8.0)B-BHS-1-TB Yeon Ho 20015WR-05A00 or SM02B-BHSS-1-TB Yeon Ho 35001WR-02A00)		
CN2-1 CN3-1	V_{HI}	High voltage connection to high Side of lamp. Connect to lamp terminal with shortest lead length. DO NOT connect to Ground.
CN2-2 CN3-2	V_{LO}	Connection to low side of lamp. Connect to lamp terminal with longer lead length. DO NOT connect to Ground
CN2, CN3 for LXM1623-12-43 (Honda QZ-19-A3MYL #02)		
CN2-3 CN3-3	V_{HI}	High voltage connection to high side of lamp. Connect to lamp terminal with shortest lead length. DO NOT connect to Ground.
CN2-1 CN3-1	V_{LO}	Connection to low side of lamp. Connect to lamp terminal with longer lead length. DO NOT connect to Ground

TABLE 1

OUTPUT CURRENT SETTINGS

SET ₁ (Pin 7)	SET ₂ (Pin 8)	Nominal Output Current
Open*	Open*	6.5mA
Open*	Ground	6.0mA
Ground	Open*	5.5mA
Ground	Ground	5.0mA

* If driven by a logic signal it should be open collector or open drain only, not a voltage source.

PHYSICAL DIMENSIONS

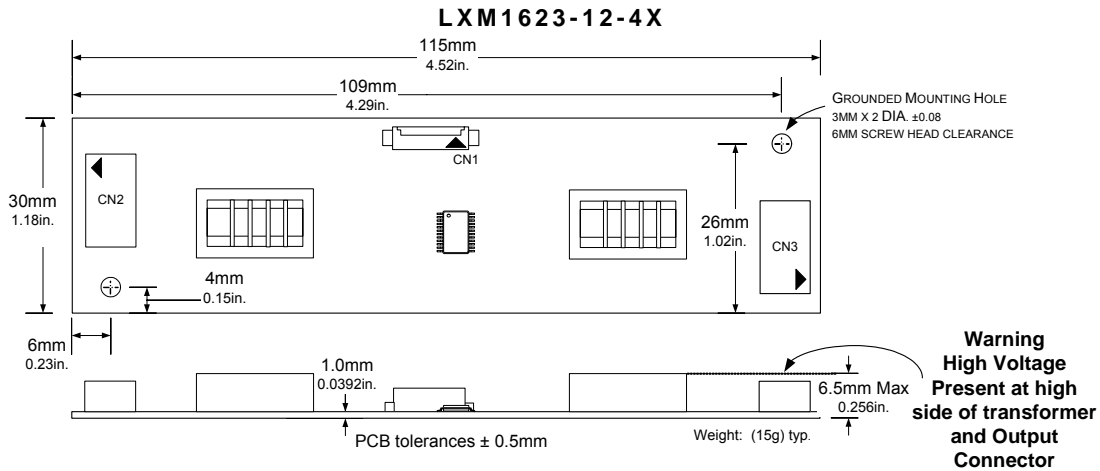

Dimensions are in millimeters (inches for reference only)

SIMPLIFIED BLOCK DIAGRAM

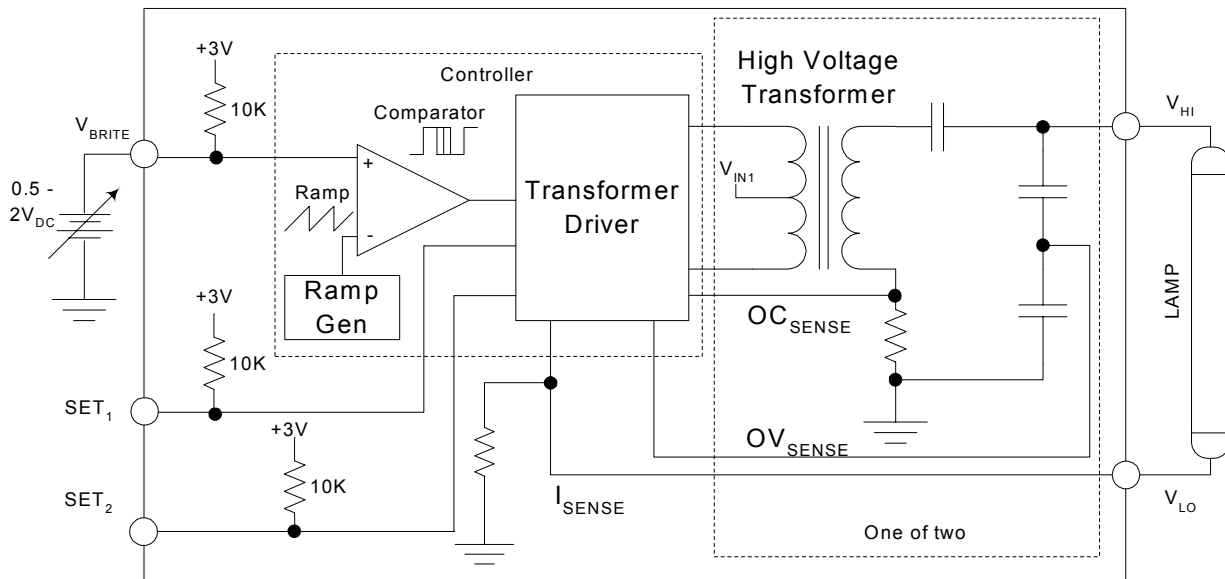

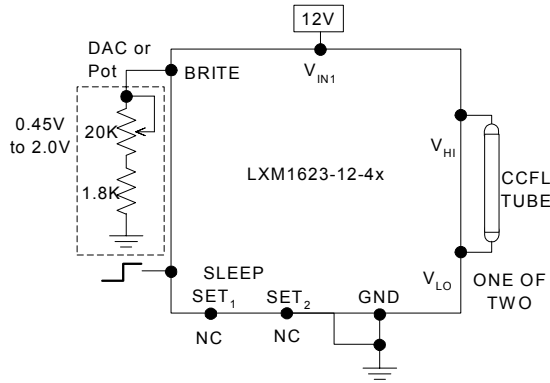
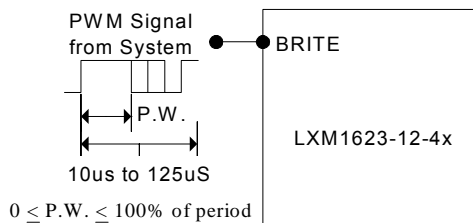
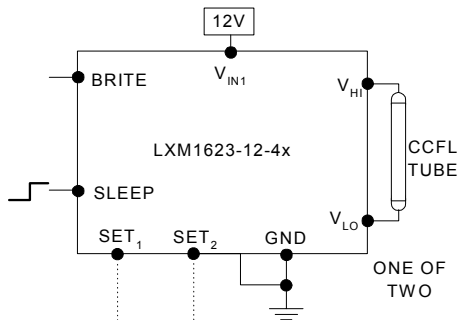
TYPICAL APPLICATION

Figure 1 – Brightness Control
 (Output current set to maximum)

Figure 1A – PWM Brightness Control

L	L	5.0mARMS
L	H	5.5mARMS
H	L	6.0mARMS
H	H	6.5mARMS

L=GND; H=Open

Figure 2 – Max Output Current
 (SET₁ and SET₂ Inputs)

- The brightness control may be a voltage output DAC or other voltage source, a digital pot or 20K manual pot. The inverter contains an internal 10K pull-up to 3V to bias the pot, add a 1.8K resistor to set the lower threshold voltage. A 3.3V Logic Level PWM signal from a micro-controller may also be used as shown in Figure 1A.
- If you need to turn the inverter ON/OFF remotely, connect to TTL logic signal to the SLEEP input.
- Connect V_{HI} to high voltage wire from the lamp. Connect V_{LO} to the low voltage wire (wire with thinner insulation). Never connect V_{LO} to circuit ground as this will defeat lamp current regulation. If both lamp wires have heavy high voltage insulation, connect the longest wire to V_{LO}. This wire is typically white.
- Use the SET₁ and SET₂ (see Figure 2) inputs to select the desired maximum output current. Using these two pins in combination allows the inverter to match a wide variety of panels from different manufactures. Generally the best lamp lifetime correlates with driving the CCFL at the manufactures nominal current setting. However the SET₁ and SET₂ inputs allow the user the flexibility to adjust the current to the maximum allowable output current to increase panel brightness at the expense of some reduced lamp life.
- Although the SET pins are designed such that just leaving them open or grounding them is all that is needed to set the output current, they can also be actively set. Using an open collector or open drain logic signal will allow you to reduce the lamp current for situations where greater dim range is required, as an example in nighttime situations. In conjunction with a light sensor or other timer the panel could be set to higher brightness (maximum output current) for daytime illumination and lower brightness (minimum or typical output current) at nighttime. Since the dim ratio is a factor of both the burst duty cycle and the peak output current, using this technique the effective dim ratio can be increased greater than the burst duty cycle alone. Conversely the SET inputs could be used to overdrive the lamp temporarily to facilitate faster lamp warm up at initial lamp turn on. Of course any possible degradation on lamp life from such practices is the users responsibility since not all lamps are designed to be overdriven.
- The inverter has a built in fault timeout function. If the output is open (lamp disconnected or broken) or shorted the inverter will attempt to strike the lamp for several seconds. After about 2 seconds without success the inverter will shutdown. In order to restart the inverter it is necessary to toggle the sleep input or cycle the V_{IN1} input supply

NOTES

PRODUCTION DATA – Information contained in this document is proprietary to Microsemi and is current as of publication date. This document may not be modified in any way without the express written consent of Microsemi. Product processing does not necessarily include testing of all parameters. Microsemi reserves the right to change the configuration and performance of the product and to discontinue product at any time.