

128MB to 8GB
USB Flash Disk Module



www.stec-inc.com

USB Solid-State Flash Disk

Capacity: 128MB - 8GB

USB 2.0 Compliant

Form Factors:

- Horizontal
- Low Profile

High Reliability:

- Endurance Guarantee of 2,000,000 Write/Erase Cycles
- Built-in Wear-leveling
- 5 Bytes Detect/4 Bytes Correct EDC/ECC
- Automatic Bad Block Management
- Single Level Cell (SLC) NAND Flash Memory
- 10 Year Data Retention

Unique Serial Number

Commercial and Industrial Operating Temperature

RoHS-6 Compliant

5-Year Warranty

SLUFDM_{xxx}(M/G)U1U(I)-y

General Description

USB Flash Disk Module (UFDM) provides non-volatile, solid-state storage in a compact design, making it perfectly suited for embedded applications. STEC's patented IC Tower® stacking technology make it possible to provide the UFDM in capacities up to 8GB, the highest in the industry. The standard USB 2.0 interface provides designers with a true plug-n-play storage device, allowing for short design cycles and fast time to market.

STEC's proprietary state-of-the-art USB 2.0 flash memory controller is incorporated in the UFDM, providing high data reliability and endurance. The flash management software that is embedded in the controller emulates a hard disk, enabling read/write operations that are identical to a standard, sector-based hard disk. Sophisticated wear leveling algorithms guarantee 2,000,000 Write/Erase Cycles, while automatic bad block management and a built-in ECC Engine guarantee the highest data reliability. Based on the Reed-Solomon algorithm, the ECC engine can detect up to 5-byte errors and correct up to 4-byte errors per 512 bytes.

USB Flash Disk Module is available with a standard 2.54mm connector or a 2.0mm low profile connector, specifically suited for designs that have Z-height constraints.

High performance, high reliability and low cost per MByte make the USB Flash Disk Module the product of choice in embedded applications, such as Gaming, POS Workstations, Networking Equipment and Industrial PCs.

STEC offers value-added services to OEM customers, such as customized form factors and test solutions, custom firmware, controlled Bill Of Materials, customer-specific labeling and serialization.

Ordering Information

USB Flash Disk Module

Part Number	FDM Form Factor	Capacity
SLUFDM128MU1U(I)-y	y=A, B	128 MBytes
SLUFDM256MU1U(I)-y	y=A, B	256 MBytes
SLUFDM512MU1U(I)-y	y=A, B	512 MBytes
SLUFDM1GU1U(I)-y	y=A, B	1 GBytes
SLUFDM2GU1U(I)-y	y=A, B	2 GBytes
SLUFDM4GU1U(I)-y	y=A, B	4 GBytes
SLUFDM8GU1U(I)-y	y=A, B	8 GBytes

Legend:

- **(M/G)** indicates if preceding capacity (xxx) is in MBytes (M) or GBytes (G).
- **U** = RoHS-6 compliant
- **(I)** = Industrial Temperature Range (-40°C to +85 °C).
- **Part numbers without (I)** = Commercial Temperature Range (0°C to 70°C).
- **(y)** = A for Horizontal **(y)** = B for Low Profile

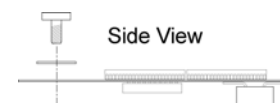
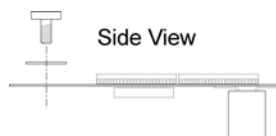

Table of Contents

1.0 Introduction	3
2.0 Product Specifications	4
2.1 Mechanical Dimensions	4
2.1.1 Horizontal	4
2.1.2 Low Profile	5
2.2 Pin Assignment	6
2.3 Signal Description	6
2.4 Performance	6
3.0 Theory of Operation	7
3.1 Block Diagram	7
3.1.1 Controller Internal Components	7
3.1.2 Controller external components	8
3.2 Flash Management	8
3.2.1 Bad Block Management	8
3.2.2 Wear Leveling	8
3.2.3 Error Correction/Detection	9
3.2.4 Power Failure Management	9
3.3 OS and Boot Support	10
3.3.1 Using USB Flash Disk Module with XP Embedded	10
3.4 Unique Serial Number	11
4.0 Environmental Specifications	12
4.1 Recommended Operating Conditions	12
4.2 Reliability	12
4.3 Shock, Vibration, and Humidity	12
4.4 Electrostatic Discharge (ESD)	13
4.5 Mean Time Between Failure (MTBF)	13
4.6 Standards Compliance	13
5.0 Electrical Specifications	14
5.1 Absolute Maximum Ratings	14
5.2 DC Characteristics	14
5.3 AC Characteristics	15
6.0 Evaluating USB Flash Disk Module	16
7.0 Product Marking	17
8.0 Revision History	18

1.0 Introduction

This datasheet includes the following sections:

- *Product Specifications* covers the most referenced specifications, such as mechanical dimensions, ball assignment, signal description, and performance.
- *Theory of Operation* explains the USB Flash Disk Module block diagram, and flash management features.
- *Environmental Specifications* characterizes the recommended operating conditions, reliability parameters and shock, vibration and humidity parameters.
- *Electrical Specifications* describes the absolute maximum ratings and AC/DC characteristics.
- *Evaluating USB Flash Disk Module* describes how designers can evaluate the USB Flash Disk Module if there is no 2x5-pin connector yet available on the hardware design.
- *Product Marking* describes the marking on the USB Flash Disk Module.



Figure 1: USB Flash Disk Module

2.0 Product Specifications

2.1 Mechanical Dimensions

2.1.1 Horizontal

Table 1 and Figure 2 show the mechanical dimensions of the USB Flash Disk Module – horizontal form factor (P/N SLUFDMxxx(M/G)U1U(I)-A).

Table 1: Mechanical dimensions - horizontal form factor

Parameter	Value
Length	37.80 ± 0.15 mm (1.488 ± 0.006 in)
Width	26.65 ± 0.15 mm (1.049 ± 0.006 in)
Height (128MB-4GB)	10.27 mm (0.404 in) max
Height (8GB)	11.16 mm (0.439 in) max

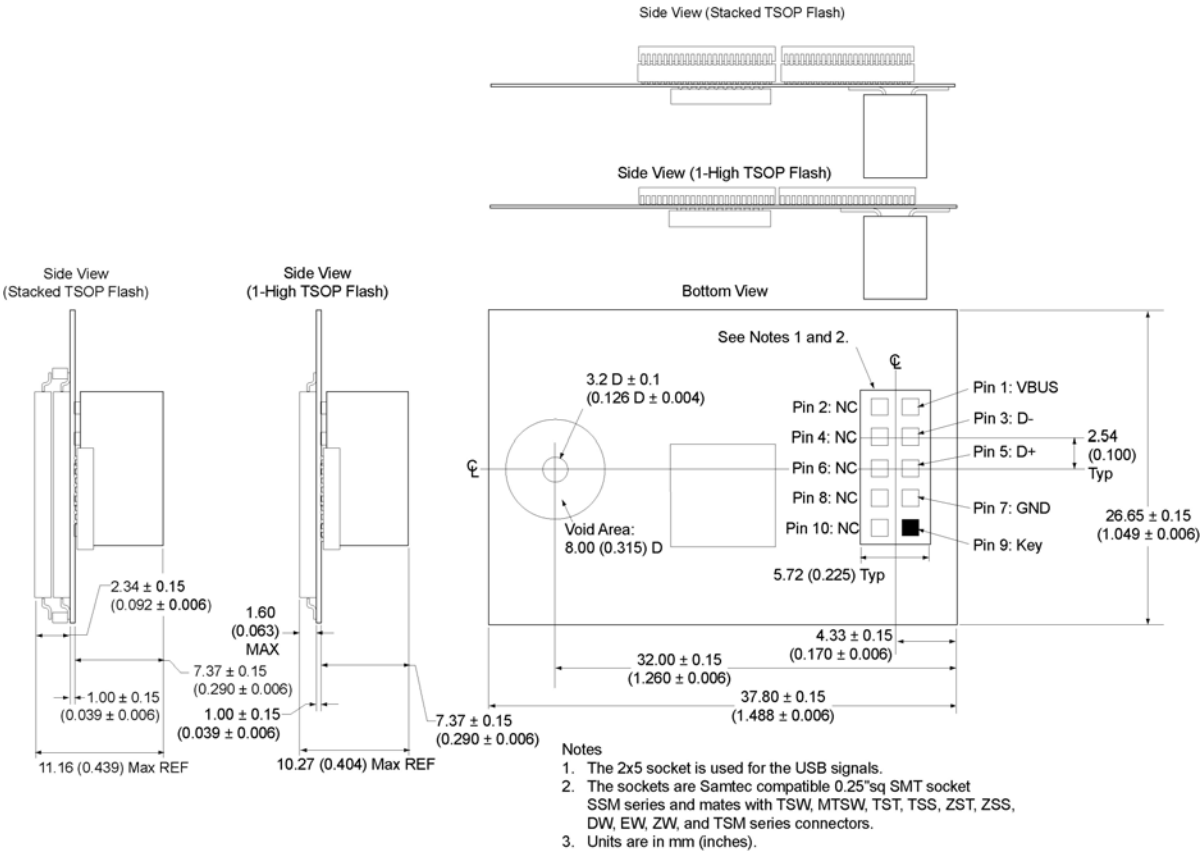

Figure 2: Mechanical dimensions - horizontal form factor

2.1.2 Low Profile

Table 2 and Figure 3 show the mechanical dimensions of the USB Flash Disk Module – low profile form factor (P/N SLUFDMxxx(M/G)U1U(I)-B).

Table 2: Mechanical dimensions – low profile form factor

Parameter	Value
Length	37.80 ± 0.15 mm (1.488 ± 0.006 in)
Width	26.65 ± 0.15 mm (1.049 ± 0.006 in)
Height (128MB-4GB)	6.46 mm (0.254 in) max
Height (8GB)	7.35 mm (0.289 in) max

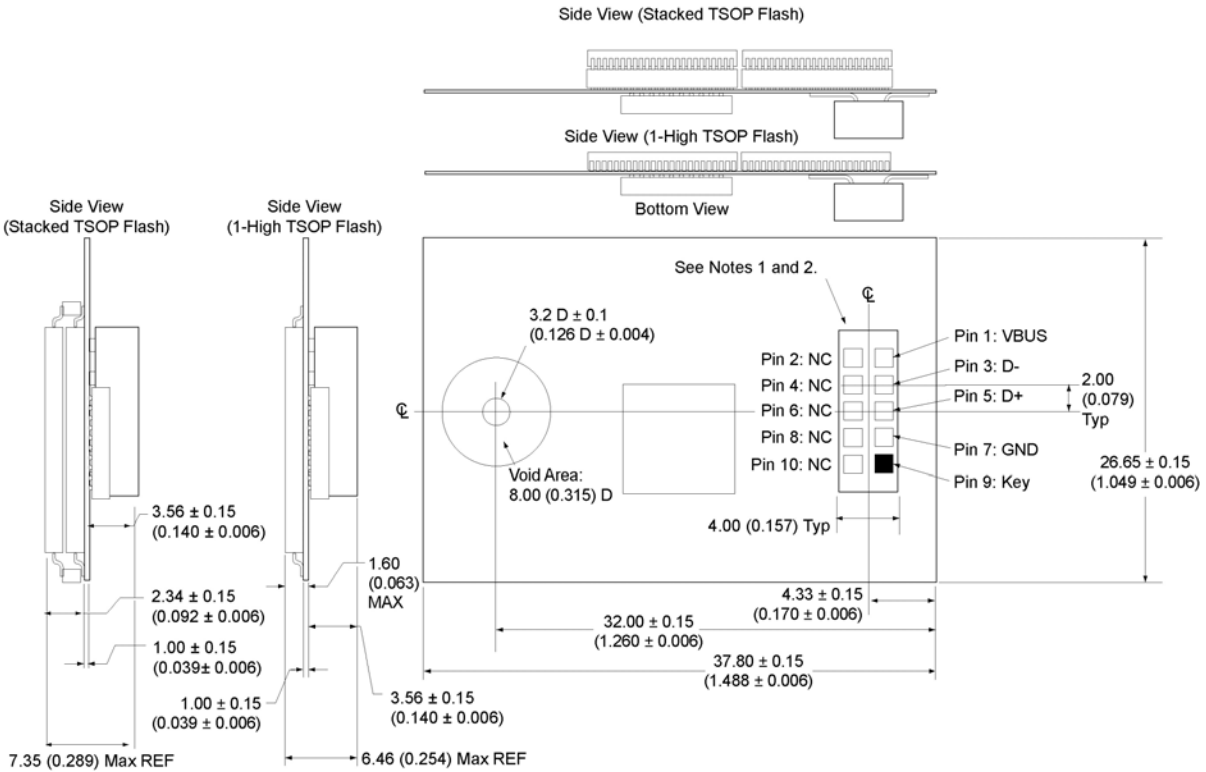

- Notes
1. The 2x5 socket is used for the USB signals.
 2. The sockets are Samtec compatible 2mm high rel socket SMM series and mates with TMM, TMMH, MTMM, MMT, LTMM, TW, and TCMD series connectors.
 3. Units are in mm (inches).

Figure 3: Mechanical dimensions – low profile form factor

2.2 Pin Assignment

Table 3: Pin Assignment

Pin Number	Signal Name	Pin Type	Pin Number	Signal Name	Pin Type
1	VBUS	Power	6	NC	I/O
2	NC	—	7	GND	Ground
3	D-	I/O	8	NC	—
4	NC	—	9	Key	Blocked Pin
5	D+	I/O	10	NC	—

2.3 Signal Description

Table 4: Signal Description

Signal Name	Type	Pin Number	Description
VBUS	Power	1	Bus voltage supply from source
D-	I/O	3	Data line –
D+	I/O	5	Data line +
GND	Ground	7	Ground
NC	Open	2, 4, 6, 8, 10	No Connect
Key	Open	9	Alignment pin

2.4 Performance

Table 5: Read/Write Performance

Parameter	Value
Sustained Read	up to 14 MB/sec
Sustained Write	up to 12 MB/sec

3.0 Theory of Operation

3.1 Block Diagram

The USB Flash Disk Module uses STEC's proprietary state-of-the-art USB 2.0 controller, combined with SLC NAND Flash for optimal device reliability. The controller's firmware supports the latest NAND flash technology from multiple vendors, and is optimized for the highest performance and reliability.

The USB Flash Disk Module controller consists of the functional blocks shown in Figure 4 and described below.

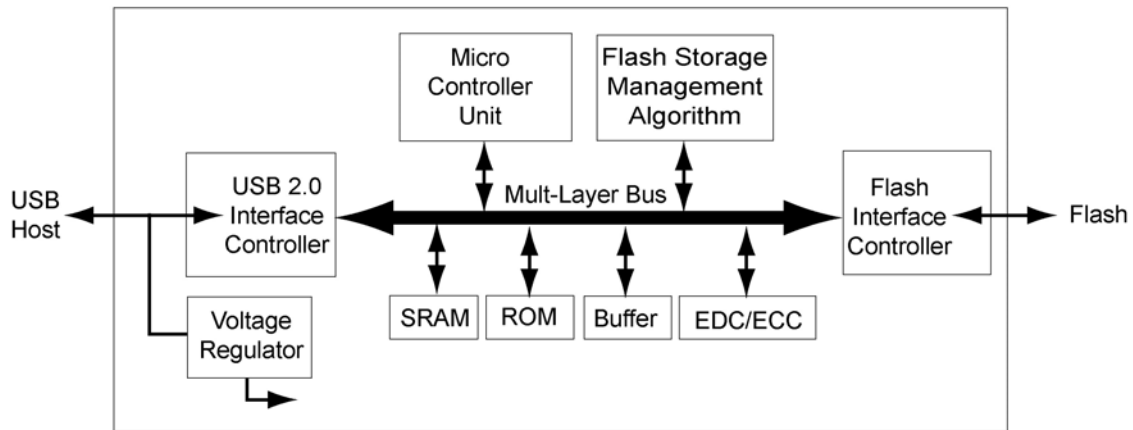

Figure 4: Controller block diagram

3.1.1 Controller Internal Components

- **Microcontroller** which serves as the hardware backbone for the flash controller algorithm.
- **USB 2.0 Interface Controller** with high speed (480 Mbps) device function. This block interfaces with the host system via the USB interface.
- **Flash Interface Controller** that serves as the interface to the NAND flash components. It supports all the major NAND flash memory manufacturers.
- **Flash Storage Management Algorithm Block** is responsible for the flash management, including wear leveling, bad block management, and Error Detection and Correction.
- **EDC/ECC** block is responsible for on-the-fly error detection and correction.
- **Sector Buffer** for optimized performance.
- **SRAM** for running controller firmware fast and efficient.
- **ROM** for storing controllers boot code.

3.1.2 Controller external components

In addition to the functional blocks shown in Figure 4, the USB Flash Disk Module has the following external components:

- SLC NAND Flash for the most reliable data storage.
- Crystal Oscillator 12Mhz, as the main clock source.

3.2 Flash Management

Since the USB Flash Disk Module provides a standard USB interface to the host, no software integration is required, providing the shortest time-to-market for design engineers.

The firmware of the embedded USB 2.0 controller contains STEC's advanced flash memory management algorithms to ensure the most optimum device performance, reliability and endurance. It was designed to maximize the benefits of flash memory, while at the same time overcoming inherent NAND flash limitations. Implemented in firmware are the below features:

- Flash file system management
- Bad-block management
- Wear-leveling
- Power failure management
- Performance optimization

3.2.1 Bad Block Management

Inherent to NAND flash technology are areas (blocks) on the media that cannot be used for storage because of their high error rate. These so-called "bad blocks" are already identified by the flash vendor during manufacturing, but can also be accumulated over time during device operation.

The USB 2.0 controller contains a table that lists all the bad blocks on the device (Bad Block Table), and automatically maps out these blocks upon system initialization. During device operation it ensures that newly accumulated bad blocks are also mapped out and added to the Bad Block Table.

Bad block management is 100% transparent to the host application, which will not be aware of the location or existence of bad blocks on the media.

3.2.2 Wear Leveling

The SLC NAND flash devices that are being used in the USB Flash Disk Module are guaranteed for 100,000 Write/Erase cycles per block. This means that after approximately 100,000 erase cycles, the erase block has a higher probability for errors than the error rate that is typical to the flash. While 100,000 write/erase cycles may be good for consumer data storage, such as digital cameras, MP3 players, etc., it is not sufficient for industrial and embedded applications where data is constantly written to the device and long product life is required.

For example, operating systems that use a file system, will update the File Allocation Table (FAT) every time a write is done to the device. Without any wear leveling in place, the area on the flash where the FAT table is located would wear out faster than other areas, reducing the lifetime of the entire flash device.

To overcome this limitation, the flash management algorithm needs to make sure that each block in the device ages, i.e. is "worn out", at the same rate. The built-in wear leveling scheme makes sure

that with every write to the flash, the youngest block is used. This ensures that the full flash media is used uniformly, so that one area of the flash will not reach the endurance limits prematurely before other areas. The implemented wear leveling algorithm ensures a minimum of 2 million write/erase cycles for the entire flash media.

3.2.3 Error Correction/Detection

The USB 2.0 controller implements an advanced Error Correction/Detection scheme, based on the Reed-Solomon algorithm. The ECC engine can detect up to 5 bytes and correct up to 4 bytes per 512 bytes (symbol based). To ensure the fastest performance, both detection and correction are done on-the-fly, in hardware only.

Each time the host application writes a sector of 512 bytes to the USB Flash Disk Module, a unique ECC signature is created by the ECC engine and written together with the data to the flash. When the data is read back by the host, the ECC engine creates again a unique ECC signature. It will then compare the original written signature with the newly created signature, and sets an error flag if the two signatures are not the same. Correction of the data is done on-the-fly when the error flag is set, and the data presented to the host will be the same as the original written data. This powerful Error Correction/Detection scheme results in an overall error rate of less than 1 in 10^{14} bits, read.

3.2.4 Power Failure Management

The embedded flash management software uses algorithms that ensure data integrity, even during power failures. After each write, a *verify write flag* is set in the extra area of the flash page, while a *dismount flag* is set for the whole device during regular power-down. When a power failure occurs, both the *verify write* and the *dismount flag* will not be set, indicating a power failure during a write or erase operation. Upon the next power-up, the mapping tables will be reconstructed from the information stored in the flash memory, and the last version of the sector with a correct *verify write flag* will be used.

This mechanism ensures complete data integrity. When writing, copying, or erasing the flash device, the data format remains valid at all intermediate stages. Old data is never erased until the *verify write flag* of the new sector has been set. Therefore, a data sector cannot exist in a partially written state. The operation is either successfully completed (*verify write flag* is set) and the new data is valid, or the operation has not yet been completed or has failed, in which case the old sector contents remain valid.

3.3 OS and Boot Support

USB Flash Disk Module can be used as the OS boot and main storage device for most Microsoft Operating Systems, as well as most embedded Operating Systems, as listed in Table 6. In both modes the USB Flash Disk Module is recognized as fixed hard drive in the system.

Table 6: Supported Operating Systems

Operating System	Secondary Storage	Boot	Version
Windows XP Pro/Vista	√	√	
Windows XP Embedded	√	√	Service Pack 2007
Windows CE	√	√	4.2 and 5.0
Windows for POS (WEPOS)	√	-	
VxWorks	√	√	6.1 and up
Linux	√	√	Kernel 2.4 and up

Note: When using the USB Flash Disk Module as the OS boot device, it should be verified that the system BIOS supports booting from a USB device. Please contact your BIOS vendor to verify this.

3.3.1 Using USB Flash Disk Module with XP Embedded

When using USB Flash Disk Module with Windows XP Embedded, it is recommended that the Enhanced Write Filter (EWF) feature is implemented. The EWF intercepts calls at the sector level, and thereby eliminates many file system updates/writes to the flash. Windows XP Embedded Service Pack 2 Feature Pack 2007 introduced an additional write protect feature, called File Based Write Filter (FBWF). The new FBWF function write-protects embedded devices at the file level, in contrast to the EWF, which has been protecting devices at the sector level.

FBWF and EWF, combined with the built-in wear leveling algorithm, ensure that the maximum life span of the flash device is achieved.

3.4 Unique Serial Number

During manufacturing stage, a unique serial number is written to the USB Flash Disk Module that includes a date code related to the time of manufacturing.

The serial number uses the following format: STI[N][S][YY][DDD][HHMMSS]. Table 7 below describes the parameters of the serial number.

Table 7: Unique Serial Number format

Symbol	Parameter
STI	STEC vendor symbol
N	Number of Test Tower
S	Number of USB socket in Test Tower
YY	Year
DDD	Day of Year (1-365)
HHMMSS	Hours, Minutes, Seconds

The Serial Number can be obtained through Windows Device Manager or Linux *lspci* utility..

4.0 Environmental Specifications

4.1 Recommended Operating Conditions

Table 8: Recommended Operating Conditions

Parameter	Symbol	Min	Typ	Max	Unit
Commercial Operating Temperature	T _A	0	25	70	°C
Industrial Operating Temperature	T _A	-40	-	85	°C
Bus Voltage	V _{BUS}	4.5	-	5.5	V

4.2 Reliability

Table 9: Endurance & Data Reliability

Parameter	Value
Endurance	2,000,000 Write/Erase Cycles
Data reliability	1 in 10 ¹⁴ bits, read
Data retention	10 years

4.3 Shock, Vibration, and Humidity

Table 10: Shock, Vibration & Humidity

Parameter	Value
Shock	1500G Peak, 0.5m pulse duration, 5 pulses, 6 axes (per JESD22-B110)
Vibration	20G Peak, 20-2000 Hz, 4 cycles per direction (X, Y and Z) (per JESD22-B103)
Humidity	85°C, 85% RH, Vmax for 500 hrs (per JESD22-A101)

4.4 Electrostatic Discharge (ESD)

USB Flash Disk Module has been tested and approved for immunity from ESD under the conditions described in Table 11 below.

Table 11: ESD Rating for USB Flash Disk Module

ESD Type	Value (KV)
Air	2, 4, 8
Contact	2, 4

4.5 Mean Time Between Failure (MTBF)

STEC estimates Mean Time Between Failure (MTBF), using a prediction methodology based on reliability data for the individual components in the USB Flash Disk Module. Table 12 below summarizes the prediction results for the USB Flash Disk Module, based on the following two methodologies:

- Telcordia Special Report SR-332, Reliability Prediction Procedure for Electronic Equipment.
- MIL-HNBK-217

The analysis was performed using Relex Software.

Table 12: USB Flash Disk Module MTBF

Product	Condition	MTBF (hours)
SLUFDM128MU1U-A	Telcordia SR-332, GB, 25°C, MIL-HNBK-217	>8,000,000
SLUFDM4GU1U-A	Telcordia SR-332, GB, 25°C, MIL-HNBK-217	>8,000,000
SLUFDM8GU1U-A	Telcordia SR-332, GB, 25°C, MIL-HNBK-217	>7,000,000

4.6 Standards Compliance

USB Flash Disk Module complies with the following standards:

- CE - EN 55022/55024
- FCC - Class B for Information Technology
- UL 60950
- RoHS-6
- USB 2.0 – Mass Storage Class

5.0 Electrical Specifications

5.1 Absolute Maximum Ratings

Table 13: Absolute Maximum Ratings

Parameter	Symbol	Value	Unit
Power Supply Voltage Relative to Ground	V_{BUS}	-0.5 to 6	V
Voltage on D+ and D- Relative to Ground	V_{DATA}	-0.5 to 3.6	V
Ambient Operating Temperature (Commercial)	T_A	0 to +70	°C
Ambient Operating Temperature (Industrial)	T_A	-40 to +85	°C

5.2 DC Characteristics

Measurements at Recommended Operating Conditions, unless otherwise specified.

Table 14: DC Characteristics for Full-Speed Operation ($T_A=25^\circ\text{C}$, $V_{dd}=3.3\text{V}$, $V_{ss}=0\text{V}$)

Parameter	Symbol	Test conditions	Min	Typ	Max	Unit
Supply Voltage	V_{BUS}		4.75	5	5.25	V
Operating current	I_{cc}	$V_{BUS}=5.0\text{V}$	60	-	90	mA
Suspend current	I_{ccs}	$V_{BUS}=5.0\text{V}$	320	-	500	μA
Input LOW Voltage	V_{IL}		-	-	0.8	V
Input HIGH Voltage	V_{IH}		2.0	-	-	V
Output LOW Voltage	V_{OL}	R_L of 1.5k Ω to 3.6V	-	-	0.3	V
Output HIGH Voltage	V_{OH}	R_L of 15k Ω to GND	2.8	-	3.6	V
Output Signal Crossover Voltage	V_{CRS}		1.3	-	2.0	V

Table 15: DC Characteristics for High-Speed Operation ($T_A=25^{\circ}\text{C}$, $V_{dd}=3.3\text{V}$, $V_{ss}=0\text{V}$)

Parameter	Symbol	Test conditions	Min	Typ	Max	Unit
Supply Voltage	V_{BUS}		4.75	5	5.25	V
Operating current	I_{CC}	$V_{BUS}=5.0\text{V}$	120	-	150	mA
Suspend current	I_{CCS}	$V_{BUS}=5.0\text{V}$	320	-	500	μA
High Speed Idle Level	V_{HSOI}		-10	-	10	mV
High Speed Data Signaling High	V_{HSOH}		360	-	440	mV
High Speed Data Signaling Low	V_{HSOL}		-10	-	10	mV
Chirp J Level (differential Voltage)	V_{CHIRPJ}		0.7	-	1.1	V
Chirp K Level (differential Voltage)	V_{CHIRPK}		-0.9	-	-0.5	mV

5.3 AC Characteristics

Measurements at Recommended Operating Conditions, unless otherwise specified.

Table 16: AC Characteristics Full Speed

Parameter	Symbol	Min	Typ	Max	Unit
Rise Time	T_{FR}	4	-	20	ns
Fall Time	T_{FF}	4	-	20	ns
Differential Rise and Fall Time Matching	T_{FRFM}	90		111.11	%
Driver Output Resistance	Z_{DRV}	28	-	44	Ω

Table 17: AC Characteristics High Speed

Parameter	Symbol	Min	Typ	Max	Unit
Rise Time (10%~90%)	T_{HSR}	500	-	-	ps
Fall Time (10%~90%)	T_{HSF}	500	-	-	ps
Driver Output Resistance	Z_{HSDRV}	40.5	-	49.5	Ω

6.0 Evaluating USB Flash Disk Module

Two 2x5 adapters are available for customers that do not have the hardware layout ready for the USB Flash Disk Module. The adapters, as shown in Figure 5, uses a standard “series A” connector and enables inserting the USB Flash Disk Module into a standard USB port on a desktop or laptop PC. The adapters are using either a standard 2.54mm connector or a 2.0mm connector for the low profile USB Flash Disk Module.

Figure 5: USB Flash Disk Module 2x5 Adapters



The 2x5 Adapters can be ordered with the following ordering information:

- **SLUFDM-2x5-ADPT-A**
- **SLUFDM-2x5-ADPT-B**

With:

- A** – Adapter for USB flash Disk Module with standard 2.54mm connector
- B** – Adapter for USB Flash Disk Module with low profile 2.0mm connector

7.0 Product Marking

USB Flash Disk Module will be shipped with 2 labels. The first label shows the manufacturing date code, which can be used for lot traceability. Table 18 below shows the information that can be found on this label.

Table 18: Manufacturing label

Kanban ID		BOM Assembly Number	
yymmdd-XXX-xxx		94000-ppppp-nnnTP	
yymmdd	Date code of manufacturing	94000*	STEC designation for OEM Flash products
XXX	SMT Line at which the part was manufactured	ppppp	PCB number
xxx	lot code	nnn	Capacity designator

* Note: If custom P/N was set up, then 94000 will be replaced with custom BOM Assembly Number designator.

The second label shows the standards for which the USB Flash Disk Module is certified (Figure 6).

Figure 6: Standards Label

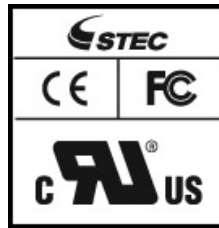

8.0 Revision History

Revision	Date	Description
-109	11/13/06	Initial release in updated format.
-110	1/12/07	Added MTBF Calculations (section 4.4), and new section on unique serial number (section 3.4). Updated Shock/Vibration/Humidity parameters.
-111	1/15/07	Updated mechanical dimensions (section 2.1)
-112	02/09/07	Updated all references from SimpleTech to STEC. Added section on Electrostatic Discharge (section 4.4), Standards Compliance (section 4.6), and Product Marking (section 7.0).
-113	03/09/07	Updated MTBF Calculations (section 4.4).
-114	4/25/07	Corrected signal description (Table 4) and supply voltage in DC characteristics parameters (Table 14). Updated mechanical drawings to include stacked version UFDM (Figure 2 and Figure 3).
-115	5/10/07	Added additional MTBF Calculations (Table 12). Product released. Password protection was not included in release, reference to this was taken out of datasheet.

STEC Inc. reserves the right to make changes to specifications and product descriptions such as, but not limited to, numbers, parameters and other technical information contained herein without notice. Contact STEC Inc. sales office to obtain the latest specification. All information in this document is provided "as is". STEC Inc. grants no warranty of any kind with respect to this document, either expressed or implied, including, but not limited to any direct, indirect, special, consequential, or incidental damages. Under no circumstances, including but not limited to negligence, shall STEC be liable for damages resulting from reliance on the information present in this document. Some States do not grant the exclusion of limitation of liability and as such this statement may not apply to you. The provisions of this datasheet do not convey to the purchaser of the device any license under any patent rights or other intellectual property rights of STEC Inc. or others. STEC prohibits the recipient of this information from the publication, transmission, or distribution of the information to any third party except as expressly permitted by STEC. STEC products are not authorized for use as critical component in life support devices or systems without express written approval of STEC, Inc.

The information provided may be subject to United States Export Controls. Such information should not be downloaded or exported (i). into (or to a national or resident of) Cuba, Iraq, Libya, North Korea, Iran, Syria, or any other country to which the United States has embargoed goods; or given to (ii). anyone on the United States Treasury Department's list of Specially Designated Nationals or the U.S. Commerce Department's Table of Deny Orders. By using the information, you represent and warrant that you are not located in, under the control of, or a national or resident of any such country or on any such list.

STEC®, Inc., reserves the right to change products or specifications without notice. ©2007 STEC®, Inc. All rights reserved.

Worldwide Headquarters
 3001 Daimler Street
 Santa Ana, California
 92705 USA
 Tel: (949) 476-1180
 Fax: (949) 476-1209
www.stec-inc.com

STEC Europe
 Donau-City-Strasse 1
 1220 Vienna, Austria
 Tel: +43 1 263 38 08
 Fax: +43 1 263 37 65
www.stec-inc.com

STEC Hong Kong
 Unit 01-02, 10/F
 88 Hing Fat Street
 Causeway Bay,
 Hong Kong
 Tel: +852-3150-8398
 Fax: +852-3150-8399
www.stec-inc.com

STEC Japan
 Landmark Tower
 20/F 2-2-1, Minato-Mirai,
 Nishi-ku
 YOKOHAMA, 220-8120,
 Japan
 Tel: +81(0) 45-670-7030
 Fax: +81(0) 45-670-7001
www.stec-inc.com

STEC Taiwan
 4F, No. 3, Lane 91,
 Dongmei Road
 Hsinchu City Taiwan
 Tel: +886-3-5733233
 Fax: +886-3-5733633
www.stec-inc.com