



## Power Bridge Rectifiers

### SKB 25

#### Features

- Square plastic case with isolated metal base plate and fast-on connectors
- Blocking voltage up to 1600 V
- High surge current
- Easy chassis mounting
- UL recognized, file no. E 63 532

#### Typical Applications\*

- Rectifier for power supplies
- Input rectifier for variable frequency drives
- Rectifier for DC motor field supplies
- Battery charger rectifiers
- Recommended snubber network:  
RC: 50 Ω, 0.1 μF (P<sub>R</sub> = 1 W)

1) Freely suspended or mounted on an insulator

2) Mounted on a painted metal sheet of min. 250 x 250 x 1 mm

$V_{RSM}, V_{RRM}$ V	$V_{VRMS}$ V	$I_D = 17 \text{ A } (T_c = 75 \text{ }^\circ\text{C})$ Types	$C_{max}$ μF	$R_{min}$ Ω
100		SKB 25/01		0,1
200		SKB 25/02		0,15
400		SKB 25/04		0,3
600		SKB 25/06		0,5
800		SKB 25/08		0,7
1200		SKB 25/12		1
1400		SKB 25/14		1,2
1600		SKB 25/16		1,5

Symbol	Conditions	Values	Units
$I_D$	$T_a = 45 \text{ }^\circ\text{C}$ , isolated <sup>1)</sup>	3,5	A
	$T_a = 45 \text{ }^\circ\text{C}$ , chassis <sup>2)</sup>	10	A
$I_{DCL}$	$T_a = 45 \text{ }^\circ\text{C}$ , isolated <sup>1)</sup>	3	A
	$T_a = 45 \text{ }^\circ\text{C}$ , chassis <sup>2)</sup>	9,5	A
	$T_a = \text{ }^\circ\text{C}$ ,		A
$I_{FSM}$	$T_{vj} = 25 \text{ }^\circ\text{C}$ , 10 ms	370	A
	$T_{vj} = 150 \text{ }^\circ\text{C}$ , 10 ms	320	A
$i^2t$	$T_{vj} = 25 \text{ }^\circ\text{C}$ , 8,3 ... 10 ms	680	A <sup>2</sup> s
	$T_{vj} = 150 \text{ }^\circ\text{C}$ , 8,3 ... 10 ms	500	A <sup>2</sup> s
$V_F$	$T_{vj} = 25 \text{ }^\circ\text{C}$ , $I_F = 150 \text{ A}$	max. 2,2	V
$V_{(TO)}$	$T_{vj} = 150 \text{ }^\circ\text{C}$	max. 0,85	V
$r_T$	$T_{vj} = 150 \text{ }^\circ\text{C}$	max. 12	mΩ
$I_{RD}$	$T_{vj} = 25 \text{ }^\circ\text{C}$ , $V_{RD} = V_{RRM}$	300	μA
	$T_{vj} = \text{ }^\circ\text{C}$ , $V_{RD} = V_{RRM} \geq V$		μA
$I_{RD}$	$T_{vj} = 150 \text{ }^\circ\text{C}$ , $V_{RD} = V_{RRM}$	5	mA
	$T_{vj} = \text{ }^\circ\text{C}$ , $V_{RD} = V_{RRM} \geq V$		mA
$t_{rr}$	$T_{vj} = 25 \text{ }^\circ\text{C}$	10	μs
$f_G$		2000	Hz
$R_{th(j-a)}$	isolated <sup>1)</sup>	15	K/W
	chassis <sup>2)</sup>	4,7	K/W
	total	2	K/W
	total	0,15	K/W
$T_{vj}$		- 40 ... + 150	°C
$T_{stg}$		- 55 ... + 150	°C
$V_{isol}$	a.c. 50 ... 60 Hz; r.m.s.; 1 s / 1 min. to heatsink	3000 / 2500 2 ± 15 %	V~
$M_s$			Nm
$M_t$			Nm
$a$			m/s <sup>2</sup>
$w$		24	g
$F_u$		20	A
Case		G 10b	

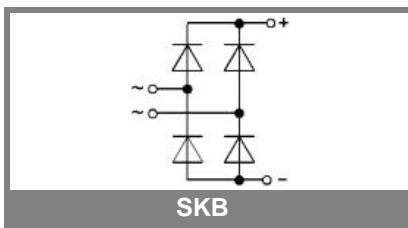

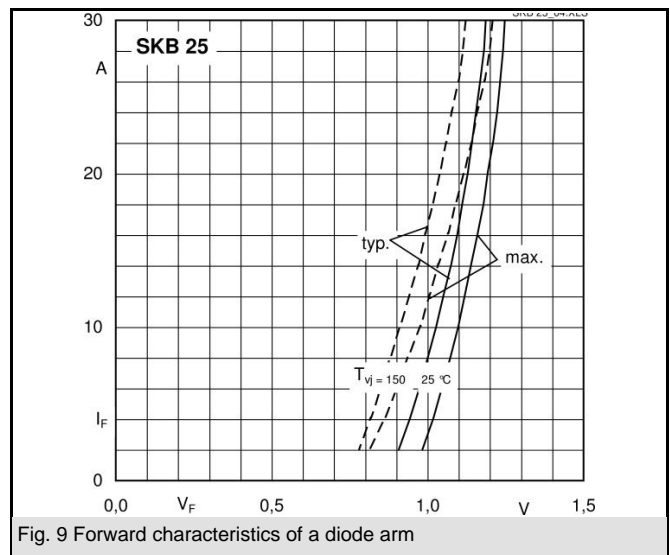
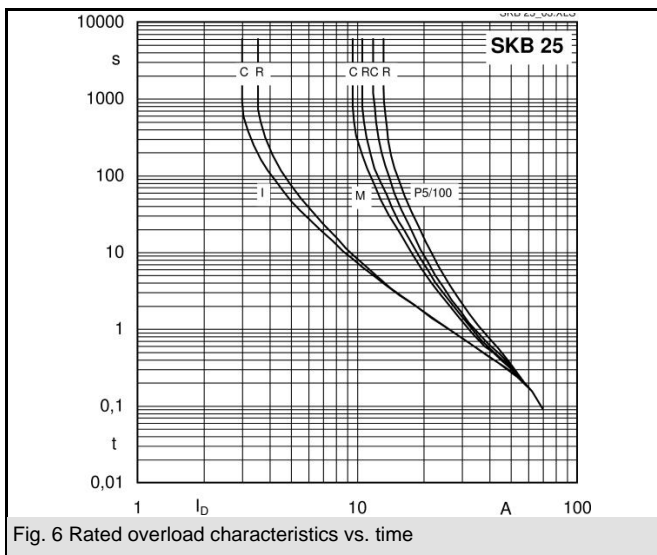
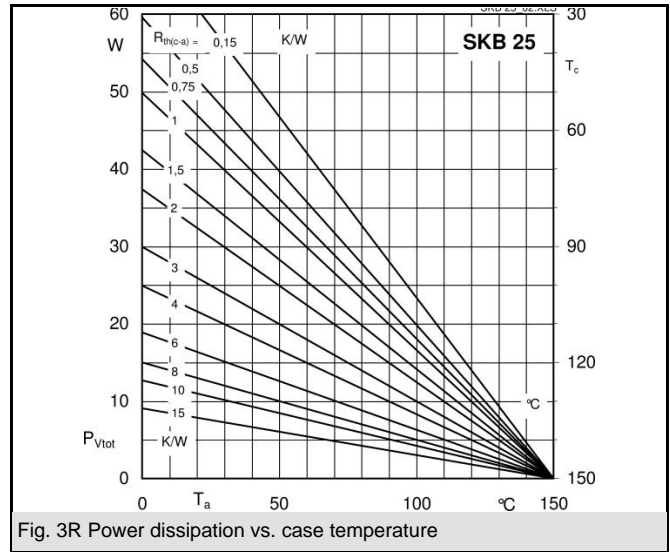
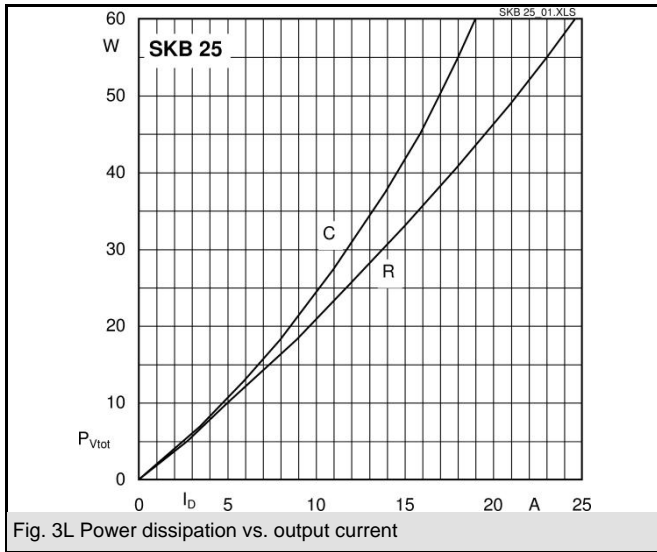

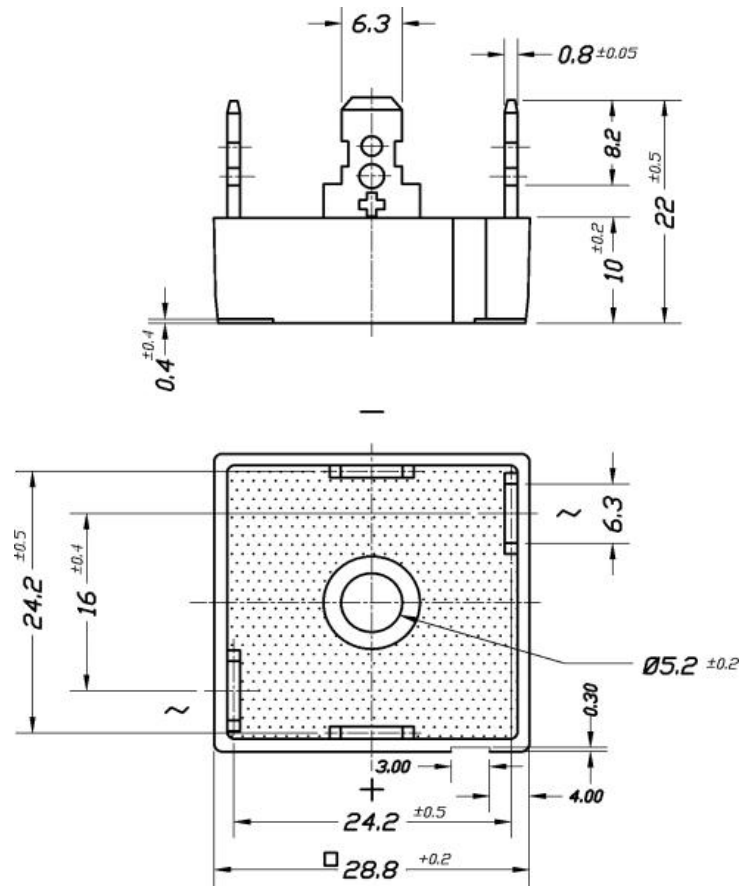

Case G 10b

\* The specifications of our components may not be considered as an assurance of component characteristics. Components have to be tested for the respective application. Adjustments may be necessary. The use of SEMIKRON products in life support appliances and systems is subject to prior specification and written approval by SEMIKRON. We therefore strongly recommend prior consultation of our personal.