

4

3

2

1

THIS DRAWING IS UNPUBLISHED. RELEASED FOR PUBLICATION
 COPYRIGHT - By - ALL RIGHTS RESERVED.

LOC	DIST	REVISIONS				
P	LTR	DESCRIPTION	DATE	DWN	APVD	
B2		REVISED PER ECO-11-005150	21MAR11	RK	HMR	

NOTES:
 1. FOR LOCAL DATA REFER TO YOUR LOCAL TE CONNECTIVITY SALES OFFICE.

2. ALL DIMENSIONS ARE NOMINAL FOR REFERENCE ONLY UNLESS OTHERWISE STATED.

3. MATERIAL : THERMOPLASTIC, UL94V-0
 HOUSING : BLACK COLOR
 CONTACTS : BRASS
 SHELL : STEEL
 BOARDLOCK : BRASS
 SCREW : BRASS

4. FINISH :
 CONTACT : 0.38µm MIN. GOLD PLATED ON CONTACT AREA
 2.54µm MIN. TIN PLATED ON SOLDERTAILS
 1.27µm MIN. NICKEL UNDERPLATED OVERALL
 SHELL : 1.52µm MIN. TIN PLATED
 BOARD LOCK : 1.52µm MIN. TIN PLATED
 SCREW : 1.27µm MIN. NICKEL PLATED.

5. CHARACTERISTICS
 CURRENT RATING : 5A
 INSULATION RESISTANCE : 1000MOHMS MIN. 500VDC FOR 2MINS.
 TEMPERATURE RATING : -55DEGC ~ +105DEGC
 VOLTAGE RATING : 250VDC

⚠️ OBSOLETE PARTS: OBSOLETE CIS STREAMLINING PER D.RENAUD/D.SINISI

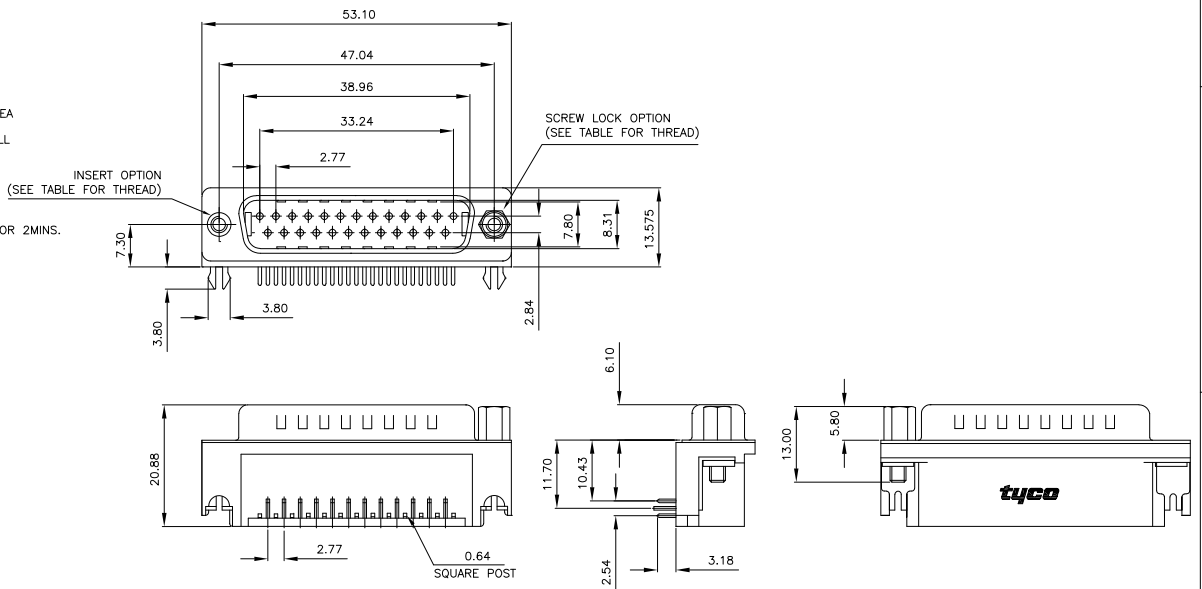

P.C.B. LAYOUT

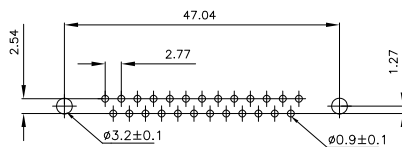

⚠️ OBSOLETE	25 WAY D PLUG WITH BOARD LOCKS & 2 x M3 SCREW LOCKS, 0.38µm GOLD, RIGHT ANGLE	4-1634582-2
⚠️ OBSOLETE	25 WAY D PLUG WITH BOARD LOCKS & 2 x 4-40 SCREW LOCKS, 0.38µm GOLD, RIGHT ANGLE	3-1634582-2
⚠️ OBSOLETE	25 WAY D PLUG WITH BOARD LOCKS & 2 x M3 INSERTS, 0.38µm GOLD, RIGHT ANGLE	2-1634582-2
⚠️ OBSOLETE	25 WAY D PLUG WITH BOARD LOCKS & 2 x 4-40 INSERTS, 0.38µm GOLD, RIGHT ANGLE	1-1634582-2

THIS DRAWING IS A CONTROLLED DOCUMENT.		DWN J.SANDWELL 15SEP2003		
DIMENSIONS: mm		CHK S.EBBUTT 15SEP2003		
TOLERANCES UNLESS OTHERWISE SPECIFIED:		APVD F.WHEELER-KING 15SEP2003	NAME 25 WAY D-SUB PLUG WITH BOARD LOCK	
0 PLC ± .05		PRODUCT SPEC	-	
1 PLC ± .02		APPLICATION SPEC	-	
2 PLC ± .01		WEIGHT	-	
3 PLC ± .005		SIZE A3	CAGE CODE 00779	DRAWING NO C-1634582
4 PLC ± .002		CUSTOMER DRAWING		
ANGLES ± .05		SCALE NTS	SHEET 1 of 2	REV B2
FINISH -		RESTRICTED TO		

4

3

2

1

THIS DRAWING IS UNPUBLISHED. RELEASED FOR PUBLICATION
 © COPYRIGHT - By - ALL RIGHTS RESERVED.

LOC		DIST		REVISIONS			
P	LTR	DESCRIPTION		DATE	DWN	APVD	
-	-	SEE SHEET 1		-	-	-	

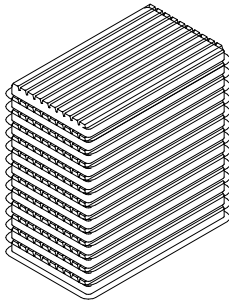

NOTES:
 1. DIMENSION:
 TRAY: L=310, W=220, H=23
 SHIPPING BOX: L=335, W=230, H=320
 2. QUANTITY:
 50 PCS/TRAY
 13 TRAY/SHIPPING BOX

COVER

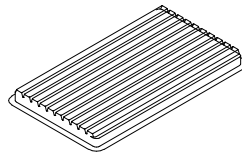

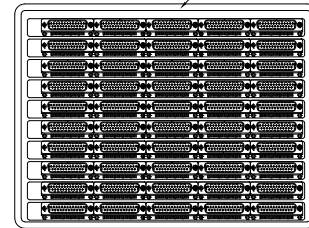

Tray Layout

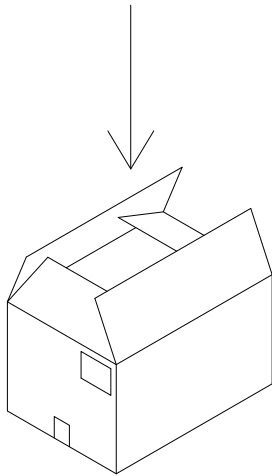
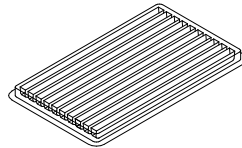

TRAY



THIS DRAWING IS A CONTROLLED DOCUMENT.		DWN	15SEP2003		 TE Connectivity						
		CHK	15SEP2003								
DIMENSIONS:		TOLERANCES UNLESS OTHERWISE SPECIFIED:		NAME	25 WAY D-SUB PLUG WITH BOARD LOCK						
mm				APVD							
		0. PLC	±	-	PRODUCT SPEC						
		1. PLC	±	-	APPLICATION SPEC						
		2. PLC	±	-	SIZE	CAGE CODE	DRAWING NO	RESTRICTED TO			
		3. PLC	±	-	A3	00779	C=1634582	-			
MATERIAL		4. PLC	±	-	WEIGHT	-	-				
SEE NOTE		ANGLES	±	-	CUSTOMER DRAWING	SCALE	NTS	SHEET	2 of 2	REV	B2