

Tous droits strictement réservés. Reproduction ou communication à des tiers
interdite sous quelque forme que ce soit sans autorisation écrite du propriétaire.
Property of FCI. Prohibits reproduction FCI.

All rights strictly reserved. Reproduction or issue to third parties in any
form whatever is not permitted without written authority from the proprietor.
Property of FCI. Copyright FCI.

PCMCIA COMPONENTS:
SINGLE DECK ASSEMBLY

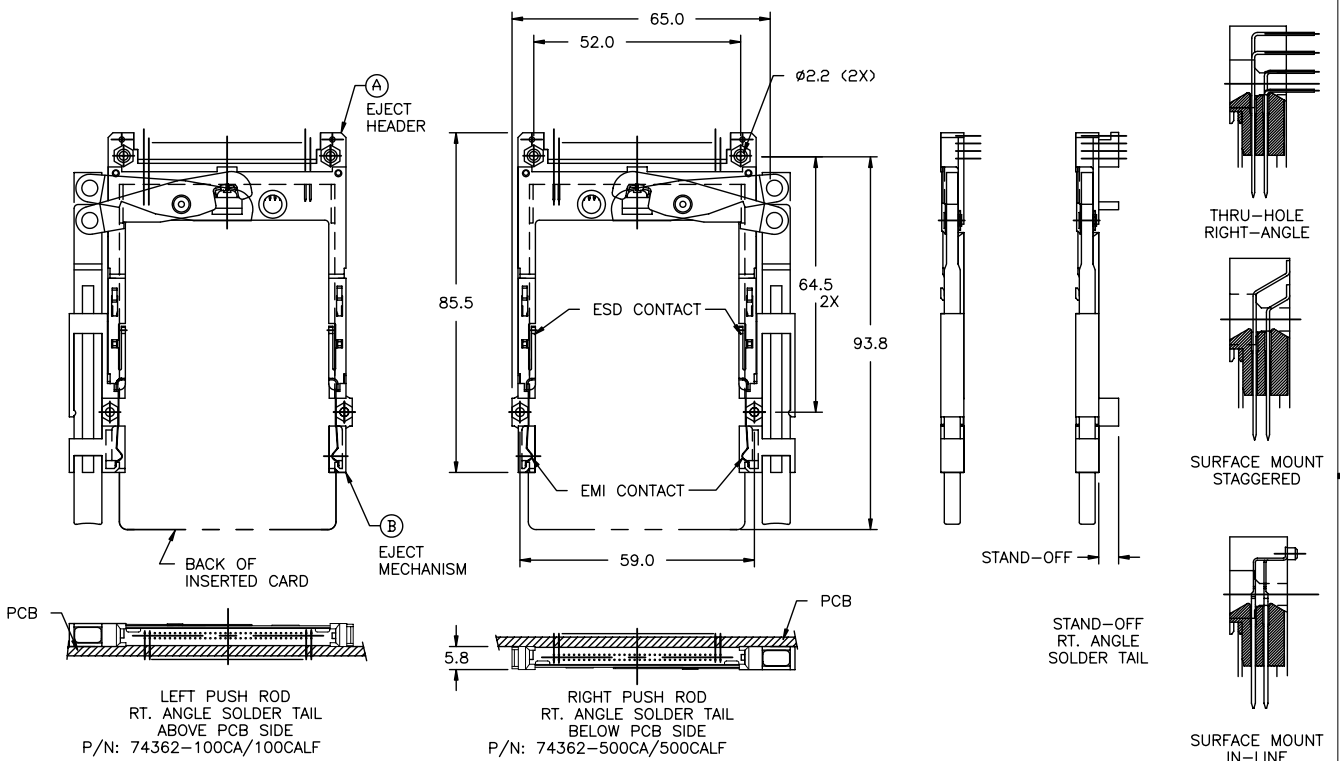

- REFER TO HEADER DRAWING 94898 AND EJECT MECHANISM 92192 FOR ADDITIONAL DIMENSIONS, MATERIAL, AND PLATING INFORMATION.
- REFER TO TA-946 FOR PCB LAYOUT AND PCB KEEP-OUT AREA.
- RECOMMENDED SCREW TORQUE: 1.0 TO 1.5 MAX in-lbs. (1.2-1.7 cm-kgs).

mat'l. code		tolerances unless otherwise specified		CUSTOMER COPY	 www.fciconnect.com
ltr	ecr no	dr	date	linear	
A	V71608	RHG	12/1/97	.X±.3	MM
B	V10948	TFG	2/28/01	.XX±.13	MM
C	V03-0452	LP	4/23/03	.XXX±.051	MM
D	V03-0517	WL	05/07/03	0° ±2°	MM
E	T03-0207	WL	05/30/03		MM
F	N05-0045	WB	02/18/05		MM
				appd	
sheet index	revision sheet	F	E	F	
		1	2	3	

title	68 POS. 3.3V EJECT HEADER ASSEMBLY
product family	MCS
size	dwg no
scale	1:1
code	A4
sheet	1 of 3
74362	

Tous droits strictement réservés. Reproduction ou communication à des tiers
interdite sous quelque forme que ce soit sans autorisation écrite du propriétaire.
Property of FCI. Prints de reproduction FCI.

All rights strictly reserved. Reproduction or issue to third parties in any
form whatever is not permitted without written authority from the proprietor.
Property of FCI. Copyright FCI.

PCMCIA COMPONENTS:
SINGLE DECK ASSEMBLY

PCB SIDE ①	PUSH ROD LOCATION ①	SOLDER TAIL ②	STANDOFF (MM)	Ⓐ EJECT HEADER	Ⓑ EJECT MECHANISM	TO MAKE FINAL ASSY PART NUMBER
ABOVE	RIGHT	R/A	NONE	94898-000	92192-00CA	74362-000CA
ABOVE	RIGHT	R/A	NONE	94898-000	92192-00DA	74362-000DA
ABOVE	LEFT	R/A	NONE	94898-000	92192-10CA	74362-100CA
ABOVE	RIGHT	R/A	2	94898-040	92192-02CA	74362-020CA
ABOVE	LEFT	R/A	2	94898-040	92192-12CA	74362-120CA
ABOVE	RIGHT	R/A	4	94898-010	92192-04CA	74362-040CA
ABOVE	LEFT	R/A	4	94898-010	92192-14CA	74362-140CA
ABOVE	RIGHT	R/A	5	94898-020	92192-05CA	74362-050CA
ABOVE	LEFT	R/A	5	94898-020	92192-15CA	74362-150CA
ABOVE	RIGHT	SMT-IL	NONE	94898-002	92192-00CA	74362-002CA
ABOVE	LEFT	SMT-IL	NONE	94898-002	92192-10CA	74362-102CA
ABOVE	LEFT	SMT-IL	NONE	94898-002H	92192-10CAH	74362-102CAH
ABOVE	RIGHT	SMT-STG	NONE	94898-001	92192-00CA	74362-001CA
ABOVE	LEFT	SMT-STG	NONE	94898-001	92192-10CA	74362-101CA
ABOVE	LEFT	SMT-STG	NONE	94898-001H	92192-10CAH	74362-101CAH
BELOW	RIGHT	R/A	NONE	94898-500	92192-10CA	74362-500CA
BELOW	LEFT	R/A	NONE	94898-500	92192-00CA	74362-600CA
BELOW	RIGHT	R/A	2	94898-540	92192-12CA	74362-520CA
BELOW	LEFT	R/A	2	94898-540	92192-02CA	74362-620CA
BELOW	RIGHT	R/A	4	94898-510	92192-14CA	74362-540CA
BELOW	LEFT	R/A	4	94898-510	92192-04CA	74362-640CA
BELOW	RIGHT	R/A	5	94898-520	92192-15CA	74362-550CA
BELOW	LEFT	R/A	5	94898-520	92192-05CA	74362-650CA
BELOW	RIGHT	SMT-IL	NONE	94898-502	92192-10CA	74362-502CA
BELOW	LEFT	SMT-IL	NONE	94898-502	92192-00CA	74362-602CA
BELOW	RIGHT	SMT-STG	NONE	94898-501	92192-10CA	74362-501CA
BELOW	LEFT	SMT-STG	NONE	94898-501	92192-00CA	74362-601CA

- NOTES:
- ① PCB SIDE AND PUSHROD LOCATION ARE AS APPEARS INSTALLED.
 - ② SOLDER TAIL KEY:
R/A = RIGHT ANGLE PIN-THROUGH-HOLE
SMT-STG = STAGGERED SURFACE MOUNT
SMT-IL = SURFACE MOUNT IN-LINE (SINGLE ROW)
 - ③ ADD "H" TO PART NUMBER FOR OPTIONAL HOLD DOWN (4 PER ASSEMBLY)

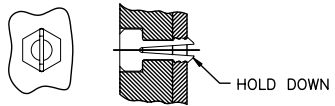

mat'l. code		tolerances unless otherwise specified		CUSTOMER COPY		 www.fciconnect.com	
ltr	ecn no	dr	date	linear	projection	title	
E					 MM	68 POS. 3.3V EJECT HEADER ASSEMBLY	
				angles	 1:1	product family	code
				dr		MCS	-
				enrg		size	dwg no
				chr		A4	74362
				appd			sheet
							2 of
sheet index	revision sheet						

Tous droits strictement réservés. Reproduction ou communication à des tiers interdite sans quelque forme que ce soit sans autorisation écrite du propriétaire. Propriété de FCI. Droits de reproduction FCI.



All rights strictly reserved. Reproduction or issue to third parties in any form whatever is not permitted without written authority from the proprietor. Property of FCI. Copyright FCI.

PCMCIA COMPONENTS: SINGLE DECK ASSEMBLY

PCB SIDE ①	PUSH ROD LOCATION ①	SOLDER TAIL ②	STANDOFF (MM)	Ⓐ EJECT HEADER	Ⓑ EJECT MECHANISM	TO MAKE FINAL ASSY PART NUMBER
ABOVE	RIGHT	R/A	NONE	94898-000LF	92192-00CA	74362-000CALF
ABOVE	RIGHT	R/A	NONE	94898-000LF	92192-00DA	74362-000DALF
ABOVE	LEFT	R/A	NONE	94898-000LF	92192-10CA	74362-100CALF
ABOVE	RIGHT	R/A	2	94898-040LF	92192-02CA	74362-020CALF
ABOVE	LEFT	R/A	2	94898-040LF	92192-12CA	74362-120CALF
ABOVE	RIGHT	R/A	4	94898-010LF	92192-04CA	74362-040CALF
ABOVE	LEFT	R/A	4	94898-010LF	92192-14CA	74362-140CALF
ABOVE	RIGHT	R/A	5	94898-020LF	92192-05CA	74362-050CALF
ABOVE	LEFT	R/A	5	94898-020LF	92192-15CA	74362-150CALF
ABOVE	RIGHT	SMT-IL	NONE	94898-002LF	92192-00CA	74362-002CALF
ABOVE	LEFT	SMT-IL	NONE	94898-002LF	92192-10CA	74362-102CALF
ABOVE	LEFT	SMT-IL	NONE	94898-002HLF	92192-10CAH	74362-102CAHLF
ABOVE	RIGHT	SMT-STG	NONE	94898-001LF	92192-00CA	74362-001CALF
ABOVE	LEFT	SMT-STG	NONE	94898-001LF	92192-10CA	74362-101CALF
ABOVE	LEFT	SMT-STG	NONE	94898-001HLF	92192-10CAH	74362-101CAHLF
BELOW	RIGHT	R/A	NONE	94898-500LF	92192-10CA	74362-500CALF
BELOW	LEFT	R/A	NONE	94898-500LF	92192-00CA	74362-600CALF
BELOW	RIGHT	R/A	2	94898-540LF	92192-12CA	74362-520CALF
BELOW	LEFT	R/A	2	94898-540LF	92192-02CA	74362-620CALF
BELOW	RIGHT	R/A	4	94898-510LF	92192-14CA	74362-540CALF
BELOW	LEFT	R/A	4	94898-510LF	92192-04CA	74362-640CALF
BELOW	RIGHT	R/A	5	94898-520LF	92192-15CA	74362-550CALF
BELOW	LEFT	R/A	5	94898-520LF	92192-05CA	74362-650CALF
BELOW	RIGHT	SMT-IL	NONE	94898-502LF	92192-10CA	74362-502CALF
BELOW	LEFT	SMT-IL	NONE	94898-502LF	92192-00CA	74362-602CALF
BELOW	RIGHT	SMT-STG	NONE	94898-501LF	92192-10CA	74362-501CALF
BELOW	LEFT	SMT-STG	NONE	94898-501LF	92192-00CA	74362-601CALF

NOTES:

- IF LEAD FREE P/N. THE HOUSING WILL WITHSTAND EXPOSURE TO 260°C PEAK TEMPERATURE
SOLDER TAIL : SMT-IL, SMT-STG CAN RESIST 40 SECONDS IN A CONVECTION, INFRA-RED OR VAPOR PHASE REFLOW OVEN.
SOLDER TAIL : R/A CAN RESIST 10 SECONDS IN A WAVE SOLDER APPLICATION WITH A 1.00MM MINIMUM THICK CIRCUIT BOARD.
- IF LEAD FREE P/N. THE PRODUCT MEETS EUROPEAN UNION DIRECTIVES AND OTHER COUNTRY REGULATIONS AS DISCRIBED IN GS-22-008
- LEAD FREE P/N PACKAGING MEETS GS-14-920 SPECIFICATION
- PCB SIDE AND PUSHROD LOCATION ARE AS APPEARS INSTALLED.
- SOLDER TAIL KEY:
R/A = RIGHT ANGLE PIN-THROUGH-HOLE
SMT-STG = STAGGERED SURFACE MOUNT
SMT-IL = SURFACE MOUNT IN-LINE (SINGLE ROW)
- ADD "H" TO PART NUMBER FOR OPTIONAL HOLD DOWN (4 PER ASSEMBLY)

mat'l. code		tolerances unless otherwise specified		CUSTOMER COPY		 www.fciconnect.com	
ltr	ecr no	dr	date	linear	.X±.3	projection	title
F					.XX±.13	 68 POS. 3.3V EJECT HEADER ASSEMBLY	product family MCS size dwg no A4 74362
				angles	.XXX±.051		
				dr	0° ±2°	MM	sheet
				enrg	R.GRAPE 12/1/97	scale	3 of
				chr	D.BRANN 12/1/97	1:1	
				appd	D.BRANN 12/1/97		
sheet index	revision sheet						