

# COMPACT FLASH CFT, CFS SERIES

## SPECIFICATIONS

For complete specifications see [www.samtec.com/CFT](http://www.samtec.com/CFT)

**Insulator Material:** Black Liquid Crystal Polymer



**Terminal Material:** Phosphor Bronze

**Plating:** Sn or Au over 50µ" (1,27µm) Ni

**Current Rating:** 2A @ 80°C ambient

**Operating Temp Range:** -55°C to +105°C with Tin; -55°C to +125°C with Gold

**Max Processing Temp:** 230°C for 60 seconds, or 260°C for 20 seconds 3x with Matte Sn plating

**Lead-Free Solderable:** Yes, with Matte Sn

**SMT Lead Coplanarity:** (0,15mm) .006" max

## APPLICATION

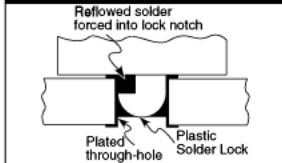

**Note:** Some lengths, styles and options are non-standard, non-returnable.

**CFT - 125 - LEAD STYLE - PLATING OPTION - D - RA - CARD LENGTH - SL**

Mates with: CFS

Specify LEAD STYLE from chart

**-L or -LM**  
= 10µ" (0,25µm) Gold on post, Tin (-L) or Matte Tin (-LM) on tail

**-S or -SM**  
= 30µ" (0,76µm) Gold on post, Tin (-S) or Matte Tin (-SM) on tail

**-01**  
= (25,40mm) 1.00" Card Length

**-02**  
= (50,80mm) 2.00" Card Length

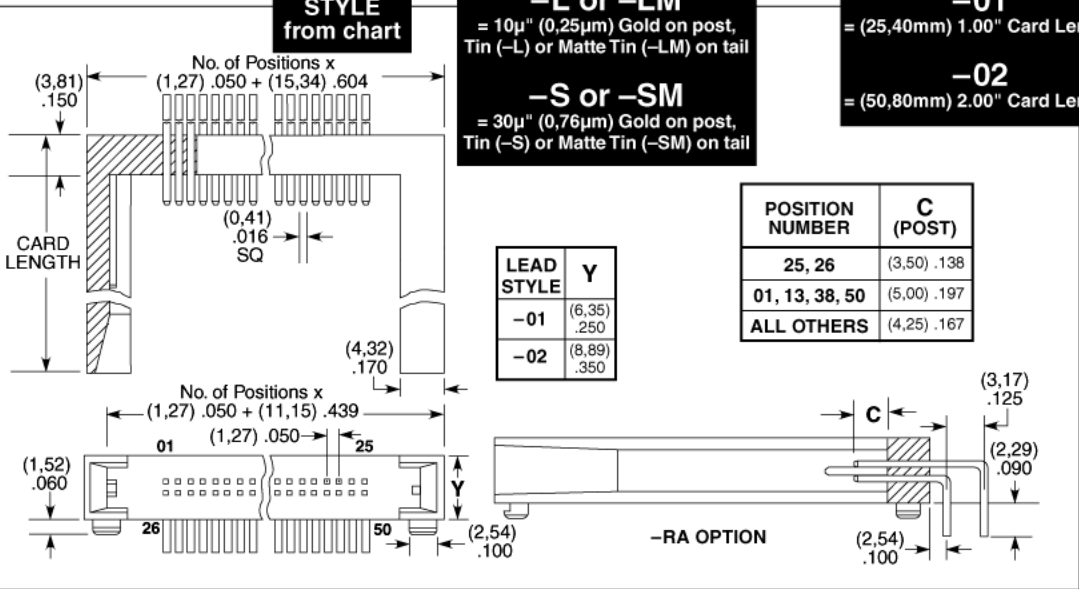

## SPECIFICATIONS

For complete specifications see [www.samtec.com/CFS](http://www.samtec.com/CFS)

**Insulator Material:** Black Liquid Crystal Polymer



**Contact Material:** BeCu

**Plating:** Au or Sn over 50µ" (1,27µm) Ni

**Current Rating:** 1A

**Operating Temp Range:** -55°C to +125°C

**Contact Resistance:** 10 mΩ max

**Insertion Depth:** (3,05mm) .120" min

**Insertion Force:** (Single contact only) 3.3oz (0,92N) avg.

**Withdrawal Force:** (Single contact only) 2.5oz (0,70N) avg.

**Max Processing Temp:** 230°C for 60 seconds, or 260°C for 20 seconds 3x with Matte Sn plating

**Lead-Free Solderable:** Yes, with Matte Sn

**SMT Lead Coplanarity:** (0,10mm) .004" max



**CFS - 1 - NO. PINS PER ROW - CARD THICKNESS - PLATING OPTION - D**

Mates with: CFT

**Note:** Some sizes, styles and options are non-standard, non-returnable.

**-01**  
= (0,80mm) .031" thick board

**-02**  
= (1,60mm) .062" thick board

**-L or -LM**  
= 10µ" (0,25µm) Gold on contact, Tin (-L) or Matte Tin (-LM) on tail

**-S or -SM**  
= 30µ" (0,76µm) Gold on contact, Tin (-S) or Matte Tin (-SM) on tail

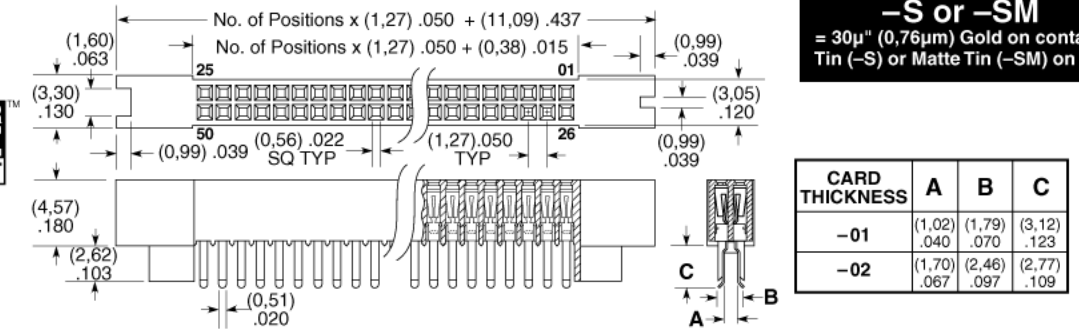

Due to technical progress, all designs, specifications and components are subject to change without notice.

[WWW.SAMTEC.COM](http://WWW.SAMTEC.COM)

SAMTEC USA • Tel: 1-800-SAMTEC-9 or 812-944-6733 • Fax: 812-948-5047  
 SAMTEC GERMANY • Tel: +49 (0) 89 / 89460-0 • Fax: +49 (0) 89 / 89460-299  
 SAMTEC JAPAN • Tel: +66-84477280 • Fax: +66-844720413  
 SAMTEC ASIA PACIFIC • Tel: 65 6745-5955 • Fax: 65 6841-1502  
 SAMTEC HONG KONG • Tel: 852 2690 4058 • Fax: 852 2690 4042  
 SAMTEC SOUTH AFRICA • Tel: 27 11 4528112 • Fax: 27 86 6714432  
 SAMTEC SILICON VALLEY • Tel: 408-395-5900 • Fax: 408-395-1520  
 SAMTEC FRANCE • Tel: 01 60 95 06 60 • Fax: 01 60 95 06 61  
 SAMTEC ISRAEL • Tel: 972-3-7526600 • Fax: 972-3-7526690  
 SAMTEC CHINA • Tel: 86-21-5385-4089 • Fax: 86-21-5385-4047  
 SAMTEC UK • Tel: 01236 739292 • Fax: 01236 727113  
 SAMTEC ITALY • Tel: 39 039 6890337 • Fax: 39 039 6890315  
 SAMTEC INDIA • Tel: 91 80 306 21 612 • Fax: 91 80 5152 8187  
 SAMTEC TAIWAN • Tel: 886 02 2698-3367 • Fax: 886 02 8698-1259  
 SAMTEC ANZ • Tel: 613 9512 7747 • Fax: 613 9512 7745