

New

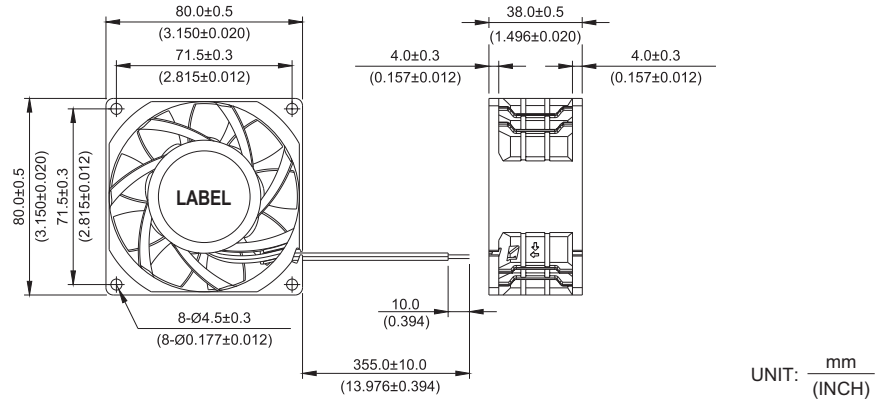

PFB 80 x 80 x 38 MM SERIES

DIMENSIONS DRAWING



- * Bearing Type: Ball Bearings
- * Material: Impeller & Frame : Plastic (UL 94V-0)
- * Lead Wires : UL 1007 AWG #24 OR Equivalent
Red Wire Positive (+)
Black Wire Negative (-)
- * Weight : 200g (7.05 oz)

P & Q CURVE (AT RATED VOLTAGE) ■ MOUNTING PANEL CUTOUT

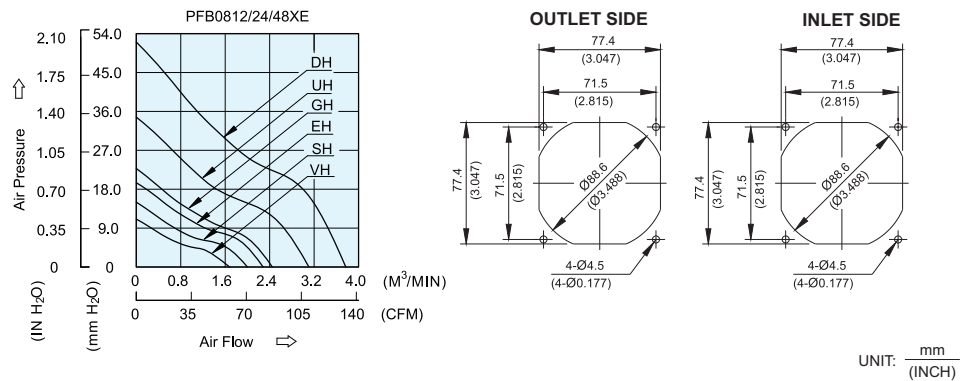

MODEL		Rated Voltage	Operating Voltage Range	Input Current	Input Power	Speed	Maximum Air Flow		Maximum Air Pressure		Noise
PART NO.	FUNCTION	VDC	VDC	Amp	Watt	R.P.M.	m ³ /min	CFM	mmH ₂ O	IN H ₂ O	dB-A
PFB0812VHE	-R00 / - F00	12	7.0 to 13.2	0.39	4.68	4200	1.649	58.23	10.70	0.421	45.1
PFB0812SHE	-R00 / - F00	12	7.0 to 13.2	0.51	6.12	4900	1.967	69.49	14.53	0.571	49.3
PFB0812EHE	-R00 / - F00	12	7.0 to 13.2	0.72	8.64	5600	2.243	79.23	19.50	0.767	53.0
PFB0824EHE	-R00 / - F00	24	14.0 to 26.4	0.36	8.64						
PFB0848EHE	-R00 / - F00	48	28.0 to 56.0	0.23	11.04						
PFB0812GHE	-R00 / - F00	12	7.0 to 13.2	0.85	10.20	6100	2.448	86.44	22.80	0.898	55.5
PFB0824GHE	-R00 / - F00	24	14.0 to 26.4	0.45	10.80						
PFB0848GHE	-R00 / - F00	48	28.0 to 56.0	0.27	12.96						
PFB0812UHE	-R00 / - F00	12	7.0 to 13.2	1.55	18.60	7500	3.038	107.30	34.75	1.368	61.0
PFB0824UHE	-R00 / - F00	24	14.0 to 26.4	0.77	18.48						
PFB0848UHE	-R00 / - F00	48	28.0 to 56.0	0.42	20.16						
PFB0812DHE	-R00 / - F00	12	7.0 to 13.2	2.75	33.00	9000	3.754	132.56	51.57	2.030	65.0
PFB0824DHE	-R00 / - F00	24	14.0 to 26.4	1.35	32.40						

* Function type is optional.
 * The max. air flow and the speed are measured in free air ; max. air pressure is measured at zero air flow.
 * Noise is measured in anechoic chamber in free air, one meter from intake side.
 * All readings are typical values at rated voltage.
 * Specifications are subject to change without notice.