

# TOSHIBA

## MICROWAVE SEMICONDUCTOR

### TECHNICAL DATA

MICROWAVE POWER GaAs FET

## JS8853-AS

#### FEATURES:

- HIGH POWER  
P<sub>1dB</sub> = 28.0 dBm at f = 15 GHz
- HIGH GAIN  
G<sub>1dB</sub> = 7.0 dB at f = 15 GHz
- SUITABLE FOR Ku-BAND AMPLIFIER
- ION IMPLANTATION
- CHIP FORM

#### RF PERFORMANCE SPECIFICATIONS (T<sub>a</sub> = 25° C)

TYPE NUMBER				JS8853-AS (CHIP)			
CHARACTERISTIC	SYMBOL	CONDITION	UNIT	MIN.	TYP.	MAX.	
Output Power at 1dB Compression Point	P <sub>1dB</sub>	V <sub>DS</sub> =10V	15GHz	dBm	27.0	28.0	-
			18GHz		-	27.0	-
Power Gain at 1dB Compression Point	G <sub>1dB</sub>		15GHz	dB	6.0	7.0	-
			18GHz		-	6.0	-
Drain Current	I <sub>DS</sub>		15GHz	A	-	0.20	0.4
			18GHz		-	0.21	0.4
Power Added Efficiency	η <sub>add</sub>	15GHz	%	-	25	-	
		18GHz		-	18	-	

#### ELECTRICAL CHARACTERISTICS (T<sub>a</sub> = 25° C)

TYPE NUMBER				JS8853-AS (CHIP)		
CHARACTERISTIC	SYMBOL	CONDITION	UNIT	MIN.	TYP.	MAX.
Trans-conductance	g <sub>m</sub>	V <sub>DS</sub> = 3V I <sub>DS</sub> = 0.23A	mS	-	150	-
Pinch-off Voltage	V <sub>GSoff</sub>	V <sub>DS</sub> = 3V I <sub>DS</sub> = 8mA	V	-2.5	-3.5	-5
Saturated Drain Current	I <sub>DSS</sub>	V <sub>DS</sub> = 3V V <sub>GS</sub> = 0V	A	-	0.5	0.65
Gate to Source Breakdown Voltage	V <sub>GS0</sub>	I <sub>GS</sub> = -8μA	V	-5	-	-
Thermal Resistance	R <sub>th(c-c)</sub>	Channel to case	°C/W	-	17	30

- ★ The information contained herein is presented only as a guide for the applications of our products. No responsibility is assumed by TOSHIBA for any infringements of patents or other rights of the third parties which may result from its use. No license is granted by implication or otherwise under any patent or patent rights of TOSHIBA or others.
- ★ The information contained herein may be changed without prior notice. It is therefore advisable to contact TOSHIBA before proceeding with the design of equipment incorporating this product.



TOSHIBA CORPORATION

Revised May 1989

# JS8853-AS

## ABSOLUTE MAXIMUM RATINGS (Ta=25°C)

TYPE NUMBER			JS8853-AS (CHIP)
CHARACTERISTIC	SYMBOL	UNIT	RATING
Drain-Source Voltage	V <sub>DS</sub>	V	15
Gate-Source Voltage	V <sub>GS</sub>	V	-5
Drain Current	I <sub>D</sub>	A	0.65
Total Power Dissipation (T <sub>c</sub> =25°C)	P <sub>T</sub>	W	5
Channel Temperature	T <sub>ch</sub>	°C	175
Storage Temperature	T <sub>stg</sub>	°C	-65~175

## POWER DISSIPATION VS. CASE TEMPERATURE

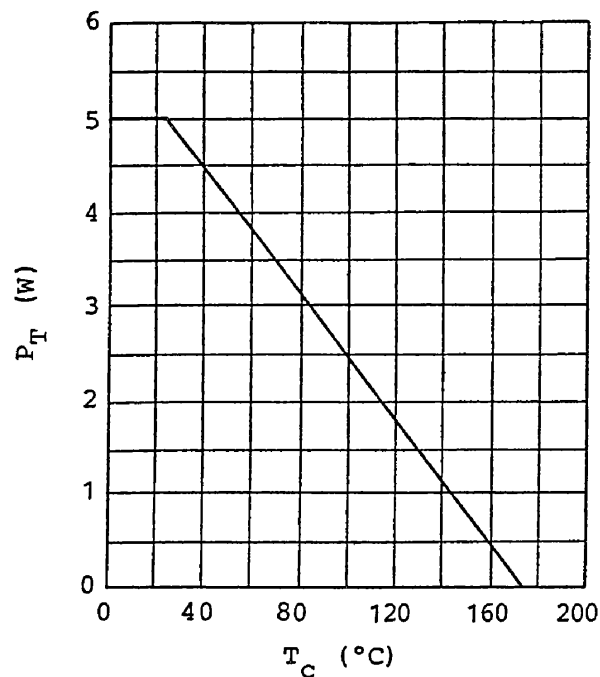

# JS8853-AS

## CHIP OUTLINE

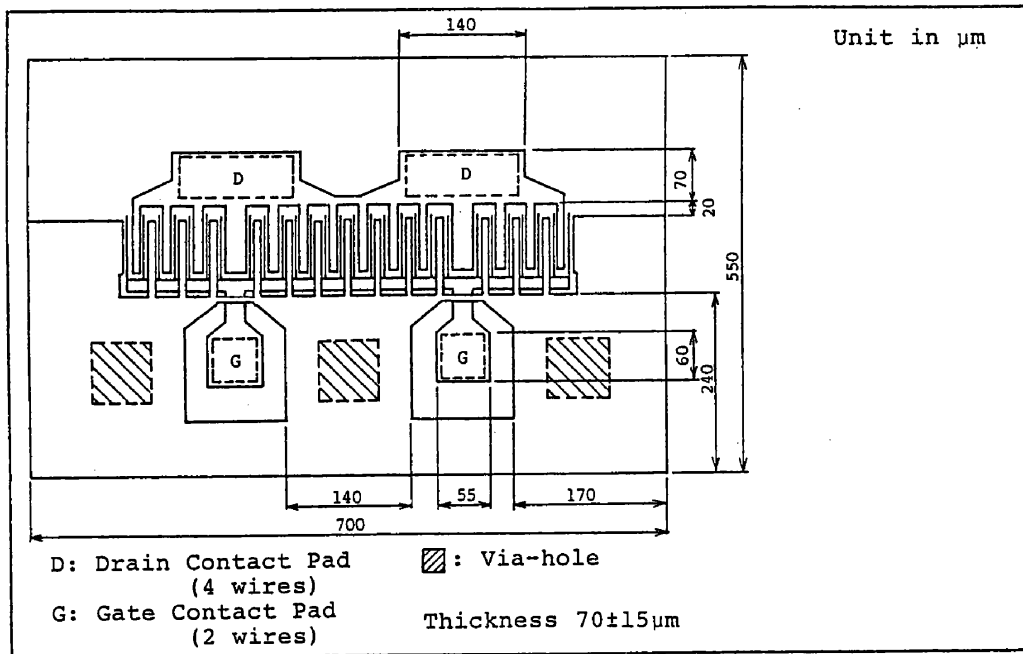

### ASSEMBLY PRECAUTIONS FOR CHIP

The operations must be performed in a clean and dry environment. The chips must be kept in the same environment when they are not used. All test instruments, assembly machines, benches, tweezers and operators should be grounded to avoid damage due to electrostatic discharge. Careful attention must be paid in handling chips with tweezers because GaAs is more brittle than Si.

### DIE ATTACHMENT

Die attachment can be accomplished with Au-Sn preform in nitrogen atmosphere. The operating temperature must be  $290 \pm 10^\circ\text{C}$  for the preform to be well melted. The operating time should be kept within one minute.

### WIRE BONDING

Bonding should be performed with thermal compression wedge bonder in nitrogen atmosphere. The recommended conditions of wire bonding are as follows:

- (1) Operating temperature .....  $200 \pm 10^\circ\text{C}$
- (2) Operating time ..... 5 minutes max.
- (3) Bonding wire ..... 25  $\mu\text{m}$  diameter pure Au

# JS8853-AS

## RF PERFORMANCES

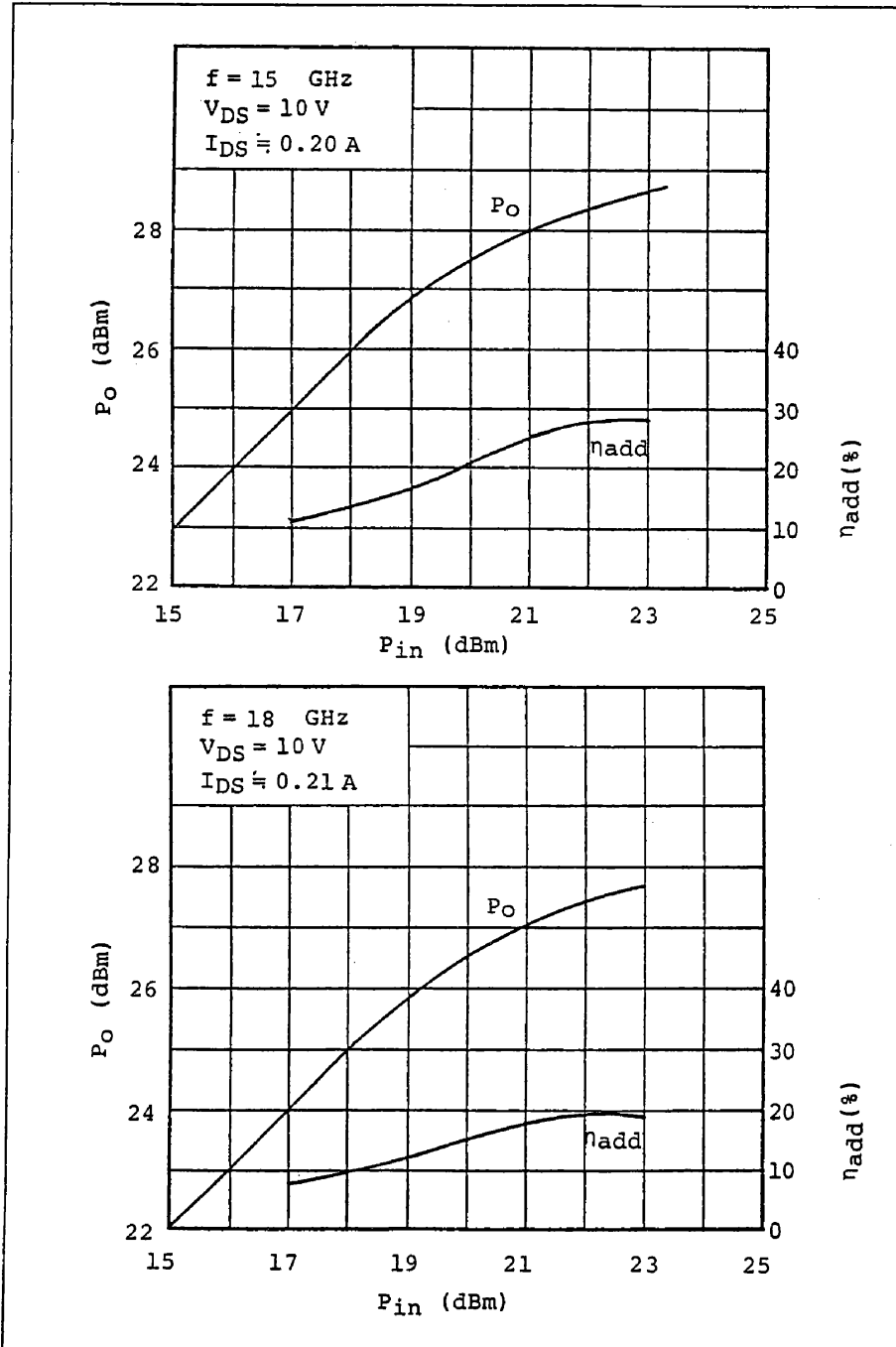

# JS8853-AS

## DRAWING OF MATCHING NETWORK FOR JS8853-AS

Unit in mm

(f=15 GHz)

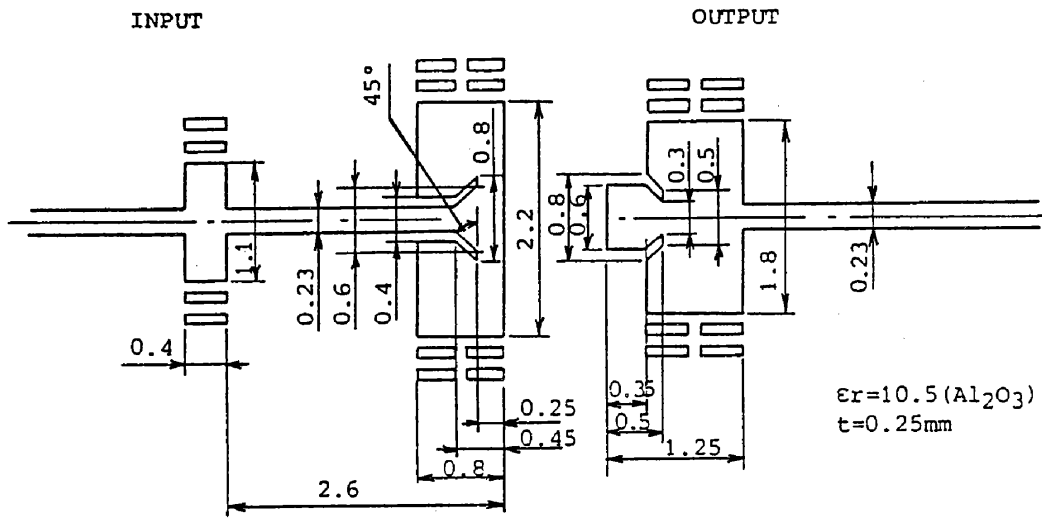

(f=18 GHz)

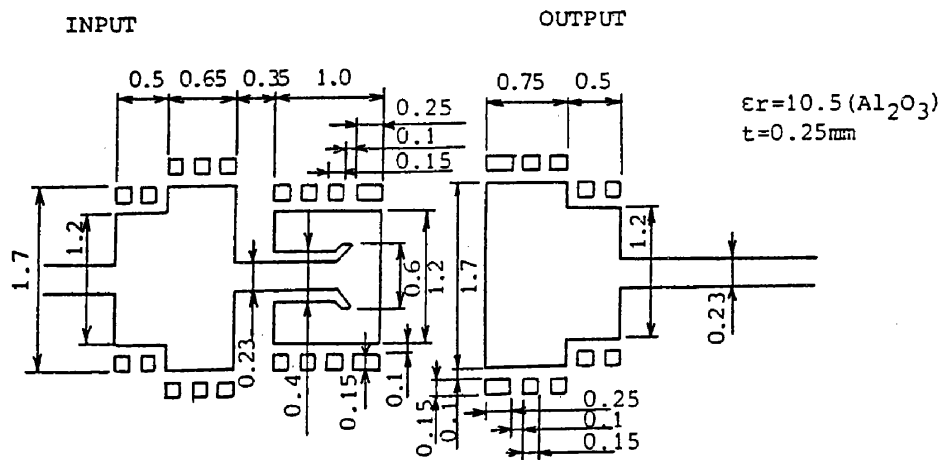

# JS8853-AS

## JS8853-AS S-PARAMETERS (MAGN. and ANGLES)

$V_{DS} = 10 \text{ V}$ ,  $I_{DS} = 200 \text{ mA}$

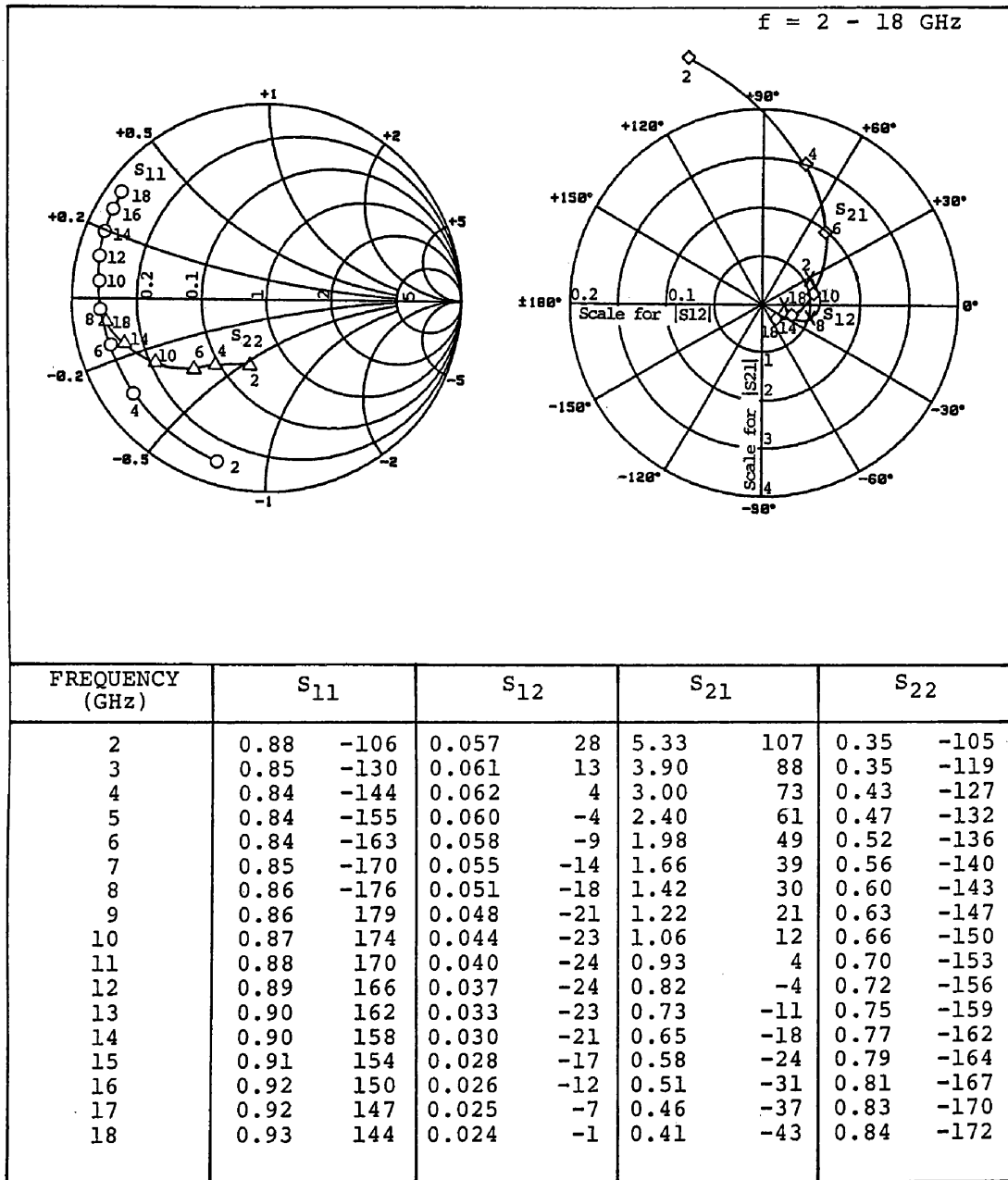

# JS8853-AS

## EQUIVALENT CIRCUIT (Includes normal bonding wires)

JS8853-AS :  $V_{DS} = 10 \text{ V}$ ,  $I_{DS} = 200 \text{ mA}$

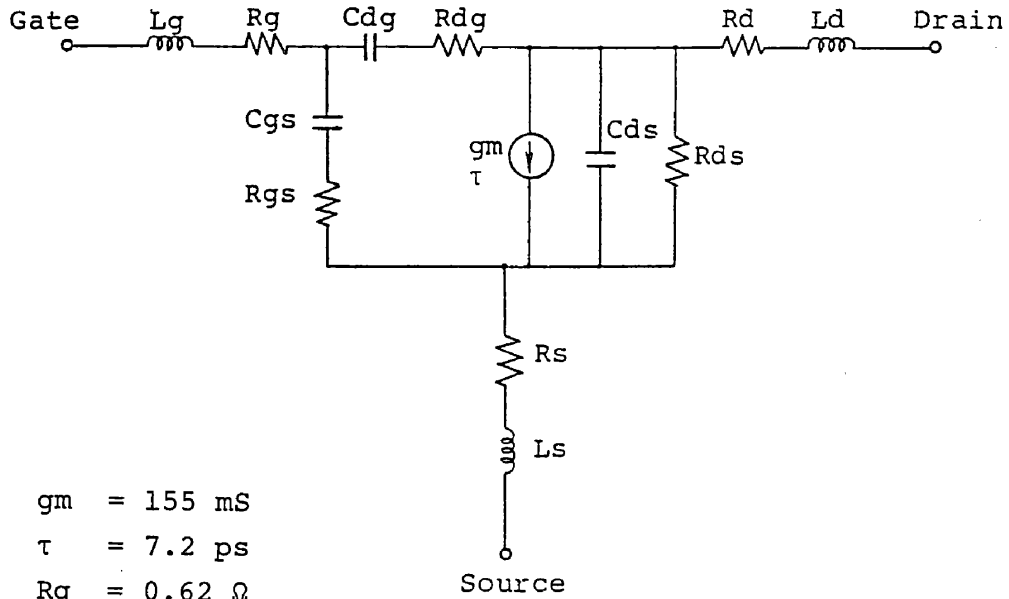

$g_m = 155 \text{ mS}$   
 $\tau = 7.2 \text{ ps}$   
 $R_g = 0.62 \text{ } \Omega$   
 $R_s = 0.34 \text{ } \Omega$   
 $R_d = 0.56 \text{ } \Omega$   
 $R_{gs} = 0.56 \text{ } \Omega$   
 $R_{gd} = 0.01 \text{ } \Omega$   
 $R_{ds} = 80 \text{ } \Omega$   
 $C_{gs} = 1.40 \text{ pF}$   
 $C_{dg} = 0.12 \text{ pF}$   
 $C_{ds} = 0.62 \text{ pF}$   
 $L_g = 0.19 \text{ nH}$   
 $L_s = 0.01 \text{ nH}$   
 $L_d = 0.07 \text{ nH}$

### Bonding wire condition

	Number (pcs)	Length (Approx.) (mm)	Dia. ( $\mu\text{m}$ )
Drain	4	0.4	$\phi 25$
Gate	2	0.4	$\phi 25$