

LOW POWER NPN SILICON TRANSISTOR

Qualified per MIL-PRF-19500/391

DEVICES

| | | |
|----------------|----------------|-----------------|
| 2N3019 | 2N3057A | 2N3700 |
| 2N3019S | | 2N3700UB |

LEVELS
JAN
JANTX
JANTXV
JANS
ABSOLUTE MAXIMUM RATINGS ($T_C = +25^\circ\text{C}$ unless otherwise noted)

| Parameters / Test Conditions | Symbol | Value | Unit |
|---|----------------|------------------|------------------|
| Collector-Emitter Voltage | V_{CEO} | 80 | Vdc |
| Collector-Base Voltage | V_{CBO} | 140 | Vdc |
| Emitter-Base Voltage | V_{EBO} | 7.0 | Vdc |
| Collector Current | I_C | 1.0 | Adc |
| Total Power Dissipation @ $T_A = +25^\circ\text{C}$ ⁽¹⁾ | P_T | 2N3019; 2N3019S | 0.8 |
| | | 2N3057A | 0.5 |
| | | 2N3700, 2N3700UB | 0.5 |
| @ $T_C = +25^\circ\text{C}$ ⁽²⁾ | | 2N3019; 2N3019S | 5.0 |
| | | 2N3057A | 1.8 |
| | | 2N3700 | 1.0 |
| | | 2N3700UB | N/A |
| Operating & Storage Jct Temp Range | T_J, T_{stg} | -65 to +200 | $^\circ\text{C}$ |

NOTE:

- Derate linearly 4.6 mW/ $^\circ\text{C}$ for type 2N3019 and 2N3019S; 2.3 mW/ $^\circ\text{C}$ for type 2N3057A; 2.85 mW/ $^\circ\text{C}$ for type 2N3700; 6.6 mW/ $^\circ\text{C}$ for type 2N3700UB for $T_A \geq +25^\circ\text{C}$
- Derate linearly 28.6 mW/ $^\circ\text{C}$ for type 2N3019 and 2N3019S; 10.3 mW/ $^\circ\text{C}$ for types 2N3057A, 2N3700 & 2N3700UB for $T_C \geq +25^\circ\text{C}$.

ELECTRICAL CHARACTERISTICS ($T_A = +25^\circ\text{C}$, unless otherwise noted)

| Parameters / Test Conditions | Symbol | Min. | Max. | Unit |
|---|---------------|------|------|-------------------------------------|
| OFF CHARACTERISTICS | | | | |
| Collector-Emitter Breakdown Current $I_C = 30\text{mAdc}$ | $V_{(BR)CEO}$ | 80 | | Vdc |
| Collector-Emitter Cutoff Current $V_{CE} = 90\text{Vdc}$ | I_{CES} | | 10 | ηAdc |
| Collector-Base Cutoff Current $V_{CB} = 140\text{V}$ | I_{CBO} | | 10 | μAdc |
| Emitter-Base Cutoff Current $V_{EB} = 7.0\text{Vdc}$ $V_{EB} = 5.0\text{Vdc}$ | I_{EBO} | | 10 | μAdc ηAdc |

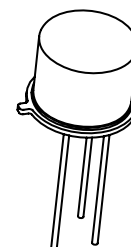
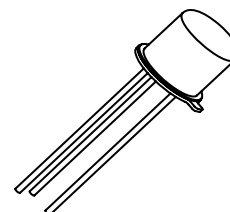
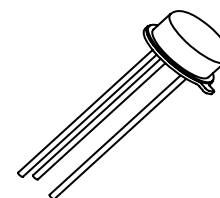
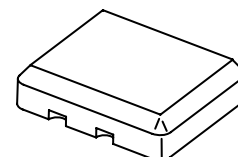
TO-05 (2N3019)
TO-39 (2N3019S)

TO-18 (TO-206AA)
2N3700

TO-46 (TO-206AB)
2N3057A

3 PIN SURFACE MOUNT
2N3700UB

ELECTRICAL CHARACTERISTICS ($T_A = +25^\circ\text{C}$, unless otherwise noted) (CONT.)

| Parameters / Test Conditions | Symbol | Min. | Max. | Unit |
|--|---------------|------|------|------|
| ON CHARACTERISTICS | | | | |
| Forward-Current Transfer Ratio $I_C = 150\text{mA}$, $V_{CE} = 10\text{Vdc}$ | h_{FE} | 100 | 300 | |
| $I_C = 0.1\text{mA}$, $V_{CE} = 10\text{Vdc}$ | | 50 | 300 | |
| $I_C = 10\text{mA}$, $V_{CE} = 10\text{Vdc}$ | | 90 | | |
| $I_C = 500\text{mA}$, $V_{CE} = 10\text{Vdc}$ | | 50 | 300 | |
| $I_C = 1.0\text{A}$, $V_{CE} = 10\text{Vdc}$ | | 15 | | |
| Collector-Emitter Saturation Voltage $I_C = 150\text{mA}$, $I_B = 15\text{mA}$ | $V_{CE(sat)}$ | | 0.2 | Vdc |
| $I_C = 500\text{mA}$, $I_B = 50\text{mA}$ | | | 0.5 | |
| Base-Emitter Saturation Voltage $I_C = 150\text{mA}$, $I_B = 15\text{mA}$ | $V_{BE(sat)}$ | | 1.1 | Vdc |

DYNAMIC CHARACTERISTICS

| Parameters / Test Conditions | Symbol | Min. | Max. | Unit |
|--|------------|------|------|------|
| Small-Signal Short-Circuit Forward Current Transfer Ratio $I_C = 1.0\text{mA}$, $V_{CE} = 5.0\text{Vdc}$, $f = 1.0\text{kHz}$ | h_{fe} | 80 | 400 | |
| Magnitude of Small-Signal Short-Circuit Forward Current Transfer Ratio $I_C = 50\text{mA}$, $V_{CE} = 10\text{Vdc}$, $f = 20\text{MHz}$ | $ h_{fe} $ | 5.0 | 20 | |
| Output Capacitance $V_{CB} = 10\text{Vdc}$, $I_E = 0$, $100\text{kHz} \leq f \leq 1.0\text{MHz}$ | C_{obo} | | 12 | pF |
| Input Capacitance $V_{EB} = 0.5\text{Vdc}$, $I_C = 0$, $100\text{kHz} \leq f \leq 1.0\text{MHz}$ | C_{ibo} | | 60 | pF |

SAFE OPERATION AREA

| | |
|--|-------------------------|
| DC Tests | |
| $T_C = 25^\circ\text{C}$, 1cycle, $t = 10\text{ms}$ | |
| Test 1 | $V_{CE} = 10\text{Vdc}$ |
| 2N3019, 2N3019S | $I_C = 500\text{mA}$ |
| 2N3057A, 2N3700, 2N3700UB | $I_C = 180\text{mA}$ |
| Test 2 | $V_{CE} = 40\text{Vdc}$ |
| 2N3019, 2N3019S | $I_C = 125\text{mA}$ |
| 2N3057A, 2N3700, 2N3700UB | $I_C = 45\text{mA}$ |
| Test 3 | $V_{CE} = 80\text{Vdc}$ |
| 2N3019, 2N3019S | $I_C = 60\text{mA}$ |
| 2N3057A, 2N3700, 2N3700UB | $I_C = 22.5\text{mA}$ |

(1) Pulse Test: Pulse Width = $300\mu\text{s}$, Duty Cycle $\leq 2.0\%$

PACKAGE DIMENSIONS

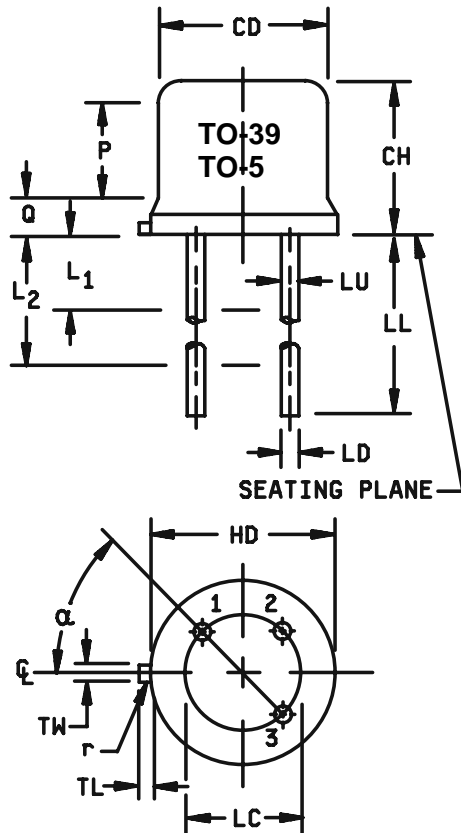

| Symbol | Dimensions | | | | Notes |
|----------------|------------|------|-------------|-------|----------|
| | Inches | | Millimeters | | |
| | Min | Max | Min | Max | |
| CD | .305 | .335 | 7.75 | 8.51 | |
| CH | .240 | .260 | 6.10 | 6.60 | |
| HD | .335 | .370 | 8.51 | 9.40 | |
| LC | .200 TP | | 5.08 TP | | 6 |
| LD | .016 | .021 | 0.41 | 0.53 | 7, 8 |
| LL | .500 | .750 | 12.70 | 19.05 | 7, 8, 12 |
| LU | .016 | .019 | 0.41 | 0.48 | 7, 8 |
| L ₁ | | .050 | | 1.27 | 7, 8 |
| L ₂ | .250 | | 6.35 | | 7, 8 |
| Q | | .050 | | 1.27 | 5 |
| TL | .029 | .045 | 0.74 | 1.14 | 4 |
| TW | .028 | .034 | 0.71 | 0.86 | 3 |
| r | | .010 | | 0.25 | 10 |
| α | 45° TP | | 45° TP | | 6 |
| P | .100 | | 2.54 | | |

NOTES:

1. Dimension are in inches.
2. Millimeters are given for general information only.
3. Beyond r (radius) maximum, TW shall be held for a minimum length of .011 (0.28 mm).
4. Dimension TL measured from maximum HD.
5. Body contour optional within zone defined by HD, CD, and Q.
6. Leads at gauge plane .054 +.001 -.000 inch (1.37 +0.03 -0.00 mm) below seating plane shall be within .007 inch (0.18 mm) radius of true position (TP) at maximum material condition (MMC) relative to tab at MMC. The device may be measured by direct methods.
7. Dimension LU applies between L₁ and L₂. Dimension LD applies between L₂ and minimum. Diameter is uncontrolled in L₁ and beyond LL minimum.
8. All three leads.
9. The collector shall be internally connected to the case.
10. Dimension r (radius) applies to both inside corners of tab.
11. In accordance with ASME Y14.5M, diameters are equivalent to φx symbology.
12. For "S" suffix devices, dimension LL is 0.500 (12.70 mm) minimum, 0.750 (19.05 mm) maximum.
13. "S" suffix devices, dimension LL is 0.50 (12.70 mm) minimum, 0.75 (19.05 mm) maximum.
14. "L" suffix devices, dimension LL is 1.500 (38.10 mm) minimum, 1.750 (44.45 mm) maximum.
15. Lead 1 = emitter, lead 2 = base, lead 3 = collector.

FIGURE 1. Physical dimensions for device types 2N3019 (TO-5) and 2N3019S (TO-39).

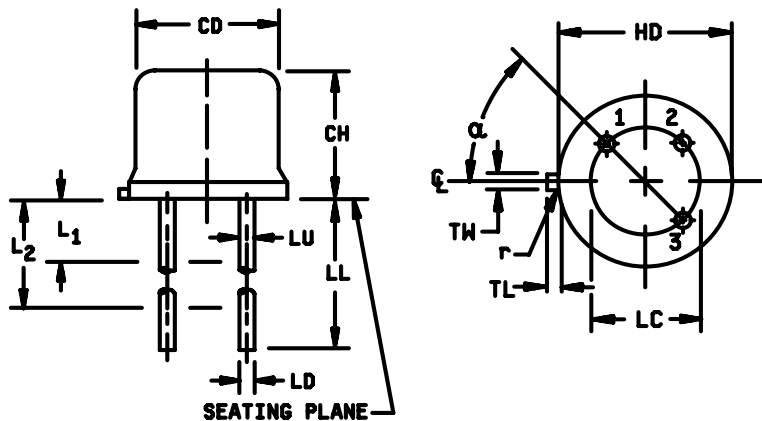

| Symbol | Dimensions | | | | Note |
|----------|------------|-------|-------------|-------|--------|
| | Inches | | Millimeters | | |
| | Min | Max | Min | Max | |
| CD | .178 | .195 | 4.52 | 4.95 | |
| CH | .065 | .085 | 1.65 | 2.16 | |
| HD | .209 | .230 | 5.31 | 5.84 | |
| LC | .100 TP | | 2.54 TP | | 6 |
| LD | .016 | .021 | 0.41 | 0.53 | 7 |
| LL | .500 | 1.750 | 12.70 | 44.45 | 7 |
| LU | .016 | .019 | 0.41 | 0.48 | 7 |
| L1 | | .050 | | 1.27 | 7 |
| L2 | .250 | | 6.35 | | 7 |
| TL | .028 | .048 | 0.71 | 1.22 | 3 |
| TW | .036 | .046 | 0.91 | 1.17 | 2 |
| r | | .007 | | 0.18 | 10, 11 |
| α | 45° TP | | 45° TP | | 6 |

NOTES:

1. Dimension are in inches.
2. Millimeters are given for general information only.
3. Beyond r (radius) maximum, TW shall be held for a minimum length of .011 inch (0.28 mm).
4. Dimension TL measured from maximum HD.
5. Leads at gauge plane .054 +.001 -.000 inch (1.37 +0.03 -0.00 mm) below seating plane shall be within .007 inch (0.18 mm) radius of true position (TP) at maximum material condition (MMC) relative to tab at MMC. The device may be measured by direct methods.
6. Dimension LU applies between L₁ and L₂. Dimension LD applies between L₂ and LL minimum. Diameter is uncontrolled in L₁ and beyond LL minimum.
7. All three leads.
8. The collector shall be internally connected to the case.
9. Dimension r (radius) applies to both inside corners of tab.
10. In accordance with ASME Y14.5M, diameters are equivalent to ϕx symbology.
11. Lead 1 = emitter, lead 2 = base, lead 3 = collector.

FIGURE 2. Physical dimensions for 2N3057A (TO-46).

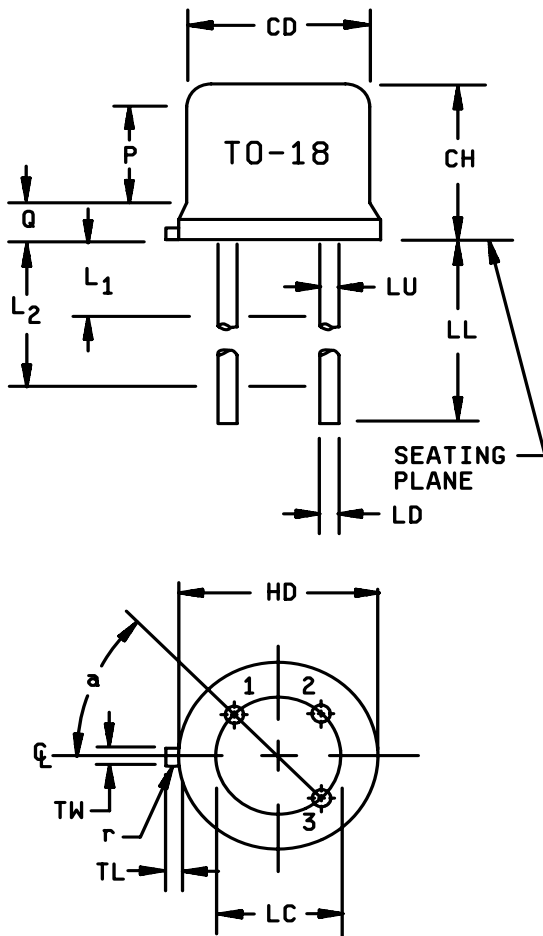

| Symbol | Dimensions | | | | Note |
|-----------------|------------|------|-------------|-------|------|
| | Inches | | Millimeters | | |
| | Min | Max | Min | Max | |
| CD | .178 | .195 | 4.52 | 4.95 | |
| CH | .170 | .210 | 4.32 | 5.33 | |
| HD | .209 | .230 | 5.31 | 5.84 | |
| LC | .100 TP | | 2.54 TP | | 6 |
| LD | .016 | .021 | 0.41 | 0.53 | 7,8 |
| LL | .500 | .750 | 12.70 | 19.05 | 7,8 |
| LU | .016 | .019 | 0.41 | 0.48 | 7,8 |
| L1 | | .050 | | 1.27 | 7,8 |
| L2 | .250 | | 6.35 | | 7,8 |
| P | .100 | | 2.54 | | |
| Q | | .030 | | 0.76 | 5 |
| TL | .028 | .048 | 0.71 | 1.22 | 3,4 |
| TW | .036 | .046 | 0.91 | 1.17 | 3 |
| r | | .010 | | 0.25 | 10 |
| α | 45° TP | | 45° TP | | 6 |
| 1, 2, 9, 11, 12 | | | | | |

NOTES:

1. Dimension are in inches.
2. Millimeters are given for general information only.
3. Beyond r (radius) maximum, TH shall be held for a minimum length of .011 inch (0.28 mm).
4. Dimension TL measured from maximum HD.
5. Body contour optional within zone defined by HD, CD, and Q.
6. Leads at gauge plane .054 +.001 -.000 inch (1.37 +0.03 -0.00 mm) below seating plane shall be within .007 inch (0.18 mm) radius of true position (TP) at maximum material condition (MMC) relative to tab at MMC. The device may be measured by direct methods or by the gauge and gauging procedure shown in figure 2.
7. Dimension LU applies between L₁ and L₂. Dimension LD applies between L₂ and LL minimum. Diameter is uncontrolled in L₁ and beyond LL minimum.
8. All three leads.
9. The collector shall be internally connected to the case.
10. Dimension r (radius) applies to both inside corners of tab.
11. In accordance with ASME Y14.5M, diameters are equivalent to ϕ x symbology.
12. Lead 1 = emitter, lead 2 = base, lead 3 = collector.

FIGURE 3. Physical dimensions for type 2N3700 (TO-18).

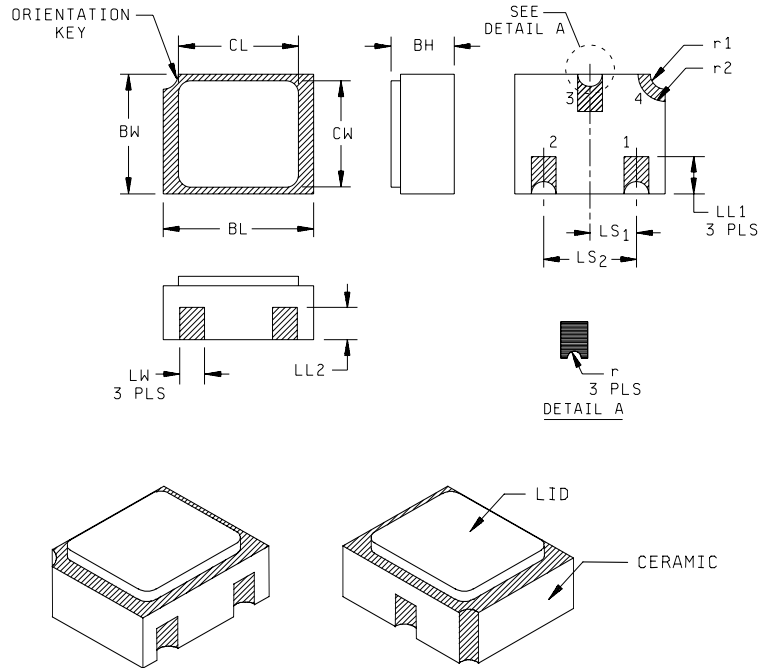

| Symbol | Dimensions | | | | Note | Symbol | Dimensions | | | | Note |
|-----------------|------------|------|-------------|------|------|-----------------|------------|------|-------------|------|------|
| | Inches | | Millimeters | | | | Inches | | Millimeters | | |
| | Min | Max | Min | Max | | | Min | Max | Min | Max | |
| BH | .046 | .056 | 1.17 | 1.42 | | LS ₁ | .035 | .039 | 0.89 | 0.99 | |
| BL | .115 | .128 | 2.92 | 3.25 | | LS ₂ | .071 | .079 | 1.80 | 2.01 | |
| BW | .085 | .108 | 2.16 | 2.74 | | LW | .016 | .024 | 0.41 | 0.61 | |
| CL | | .128 | | 3.25 | | r | | .008 | | 0.20 | |
| CW | | .108 | | 2.74 | | r ₁ | | .012 | | 0.31 | |
| LL ₁ | .022 | .038 | 0.56 | 0.96 | | r ₂ | | .022 | | 0.56 | |
| LL ₂ | .017 | .035 | 0.43 | 0.89 | | | | | | | |

NOTES:

1. Dimensions are in inches.
2. Millimeters are given for general information only.
3. Hatched areas on package denote metallized areas.
4. Pad 1 = Base, Pad 2 = Emitter, Pad 3 = Collector, Pad 4 = Shielding connected to the lid.
5. In accordance with ASME Y14.5M, diameters are equivalent to ϕx symbology.

FIGURE 4. Physical dimensions, surface mount (2N3700UB).