



# STW34NB20

N-CHANNEL 200V - 0.062  $\Omega$  - 34A TO-247

PowerMESH™ MOSFET

Table 1. General Features

Type	V <sub>DSS</sub>	R <sub>DS(on)</sub>	I <sub>D</sub>
STW34NB20	200 V	< 0.075 $\Omega$	34 A

### FEATURES SUMMARY

- TYPICAL R<sub>DS(on)</sub> = 0.062  $\Omega$
- EXTREMELY HIGH dv/dt CAPABILITY
- 100% AVALANCHE TESTED
- VERY LOW INTRINSIC CAPACITANCES
- GATE CHARGE MINIMIZED

### DESCRIPTION

Using the latest high voltage MESH OVERLAY™ process, STMicroelectronics has designed an advanced family of power MOSFETs with outstanding performances. The new patent pending strip layout coupled with the Company's proprietary edge termination structure, gives the lowest R<sub>DS(on)</sub> per area, exceptional avalanche and dv/dt capabilities and unrivalled gate charge and switching characteristics.

### APPLICATIONS

- SWITCH MODE POWER SUPPLIES (SMPS)
- DC-AC CONVERTERS FOR WELDING EQUIPMENT AND UNINTERRUPTIBLE POWER SUPPLIES AND MOTOR DRIVE
- HIGH CURRENT, HIGH SPEED SWITCHING

Figure 1. Package

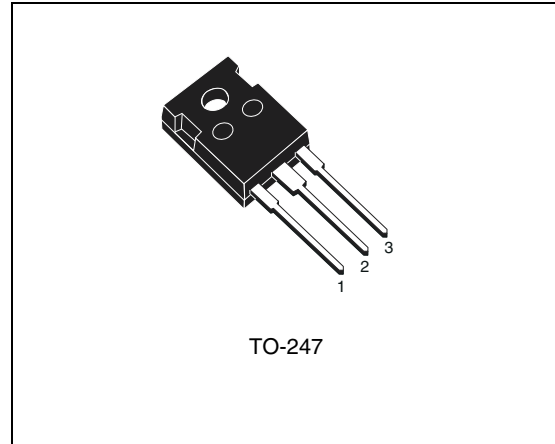

Figure 2. Internal Schematic Diagram

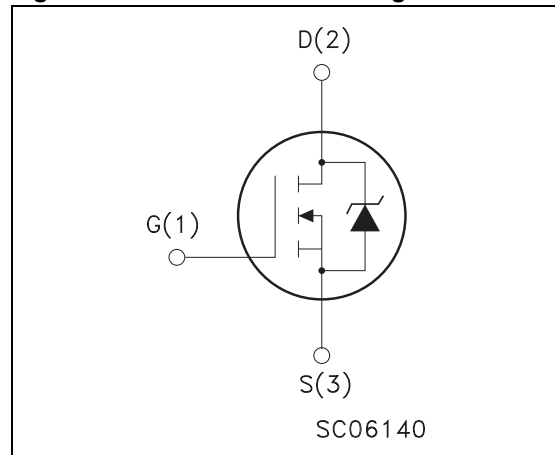

Table 2. Order Codes

Part Number	Marking	Package	Packaging
STW34NB20	W34NB20	TO-247	TUBE

**Table 3. Absolute Maximum Ratings**

Symbol	Parameter	Value	Unit
$V_{DS}$	Drain-source Voltage ( $V_{GS} = 0$ )	200	V
$V_{DGR}$	Drain- gate Voltage ( $R_{GS} = 20\text{ k}\Omega$ )	200	V
$V_{GS}$	Gate-source Voltage	$\pm 30$	V
$I_D$	Drain Current (cont.) at $T_C = 25\text{ }^\circ\text{C}$	34	A
$I_D$	Drain Current (cont.) at $T_C = 100\text{ }^\circ\text{C}$	21	A
$I_{DM}^{(1)}$	Drain Current (pulsed)	136	A
$P_{tot}$	Total Dissipation at $T_C = 25\text{ }^\circ\text{C}$	180	W
	Derating Factor	1.44	W/ $^\circ\text{C}$
$T_{stg}$	Storage Temperature	-65 to 150	$^\circ\text{C}$
$T_j$	Max. Operating Junction Temperature	150	$^\circ\text{C}$

Note: 1. Pulse width limited by safe operating area

**Table 4. Thermal Data**

Symbol	Parameter	Value	Unit
$R_{thj-case}$	Thermal Resistance Junction-case Max	0.69	$^\circ\text{C}/\text{W}$
$R_{thj-amb}$	Thermal Resistance Junction-ambient Max	30	$^\circ\text{C}/\text{W}$
$T_l$	Maximum Lead Temperature For Soldering Purpose	300	$^\circ\text{C}$

**Table 5. Avalanche Characteristics**

Symbol	Parameter	Max Value	Unit
$I_{AR}$	Avalanche Current, Repetitive or Not-Repetitive (pulse width limited by $T_j$ max, $\delta < 1\%$ )	34	A
$E_{AS}$	Single Pulse Avalanche Energy (starting $T_j = 25\text{ }^\circ\text{C}$ ; $I_D = I_{AR}$ ; $V_{DD} = 50\text{ V}$ )	650	mJ

**ELECTRICAL CHARACTERISTICS** ( $T_{\text{case}} = 25^{\circ}\text{C}$  unless otherwise specified)**Table 6. Off**

Symbol	Parameter	Test Conditions	Min.	Typ.	Max.	Unit
$V_{(\text{BR})\text{DSS}}$	Drain-source Breakdown Voltage	$I_{\text{D}} = 250 \mu\text{A}$ $V_{\text{GS}} = 0$	200			V
$I_{\text{DSS}}$	Zero Gate Voltage	$V_{\text{DS}} = \text{Max Rating}$			1	$\mu\text{A}$
	Drain Current ( $V_{\text{GS}} = 0$ )	$V_{\text{DS}} = \text{Max Rating}$ $T_{\text{c}} = 125^{\circ}\text{C}$			10	$\mu\text{A}$
$I_{\text{GSS}}$	Gate-body Leakage Current ( $V_{\text{DS}} = 0$ )	$V_{\text{GS}} = \pm 30 \text{ V}$			$\pm 100$	nA

**Table 7. On** <sup>(1)</sup>

Symbol	Parameter	Test Conditions	Min.	Typ.	Max.	Unit
$V_{\text{GS(th)}}$	Gate Threshold Voltage	$V_{\text{DS}} = V_{\text{GS}}$ ; $I_{\text{D}} = 250 \mu\text{A}$	3	4	5	V
$R_{\text{DS(on)}}$	Static Drain-source On Resistance	$V_{\text{GS}} = 10\text{V}$ ; $I_{\text{D}} = 17 \text{ A}$		0.062	0.075	$\Omega$

Note: 1. Pulsed: Pulse duration = 300  $\mu\text{s}$ , duty cycle 1.5 %**Table 8. Dynamic**

Symbol	Parameter	Test Conditions	Min.	Typ.	Max.	Unit
$g_{\text{fs}}$ <sup>(1)</sup>	Forward Transconductance	$V_{\text{DS}} > I_{\text{D(on)}} \times R_{\text{DS(on)max}}$ ; $I_{\text{D}} = 17 \text{ A}$	8	17		S
$C_{\text{iss}}$	Input Capacitance	$V_{\text{DS}} = 25 \text{ V}$ ; $f = 1 \text{ MHz}$ ; $V_{\text{GS}} = 0$		2400	3300	pF
$C_{\text{oss}}$	Output Capacitance			650	900	pF
$C_{\text{rss}}$	Reverse Transfer Capacitance			90	130	pF

Note: 1. Pulsed: Pulse duration = 300  $\mu\text{s}$ , duty cycle 1.5 %**Table 9. Switching On**

Symbol	Parameter	Test Conditions	Min.	Typ.	Max.	Unit
$t_{\text{d(on)}}$	Turn-on Time	$V_{\text{DD}} = 100 \text{ V}$ ; $I_{\text{D}} = 17 \text{ A}$ ; $R_{\text{G}} = 4.7 \Omega$		30	40	ns
$t_{\text{r}}$	Rise Time	$V_{\text{GS}} = 10 \text{ V}$ (see test circuit, Figure 16)		40	55	ns
$Q_{\text{g}}$	Total Gate Charge	$V_{\text{DD}} = 160 \text{ V}$ ; $I_{\text{D}} = 34 \text{ A}$ ; $V_{\text{GS}} = 10 \text{ V}$		60	80	nC
$Q_{\text{gs}}$	Gate-Source Charge			19		nC
$Q_{\text{gd}}$	Gate-Drain Charge			29		nC

**Table 10. Switching Off**

Symbol	Parameter	Test Conditions	Min.	Typ.	Max.	Unit
$t_{\text{r(voff)}}$	Off-voltage Rise Time	$V_{\text{DD}} = 160 \text{ V}$ ; $I_{\text{D}} = 34 \text{ A}$ ; $R_{\text{G}} = 4.7 \Omega$		17	23	ns
$t_{\text{f}}$	Fall Time	$V_{\text{GS}} = 10 \text{ V}$ (see test circuit, Figure 18)		18	24	ns
$t_{\text{c}}$	Cross-over Time			35	47	ns

Table 11. Source Drain Diode

Symbol	Parameter	Test Conditions	Min.	Typ.	Max.	Unit
$I_{SD}$	Source-drain Current				34	A
$I_{SDM}^{(1)}$	Source-drain Current (pulsed)				136	A
$V_{SD}^{(2)}$	Forward On Voltage	$I_{SD} = 34\text{ A}; V_{GS} = 0$			1.5	V
$t_{rr}$	Reverse Recovery Time	$I_{SD} = 34\text{ A}; di/dt = 100\text{ A}/\mu\text{s}$			290	ns
$Q_{rr}$	Reverse Recovery Charge	$V_{DD} = 50\text{ V}; T_j = 150\text{ }^\circ\text{C}$ (see test circuit, Figure 18)			2.7	$\mu\text{C}$
$I_{RRAM}$	Reverse Recovery Charge				18.5	A

Note: 1. Pulse width limited by safe operating area  
 2. Pulsed: Pulse duration = 300  $\mu\text{s}$ , duty cycle 1.5 %

Figure 3. Safe Operating Area

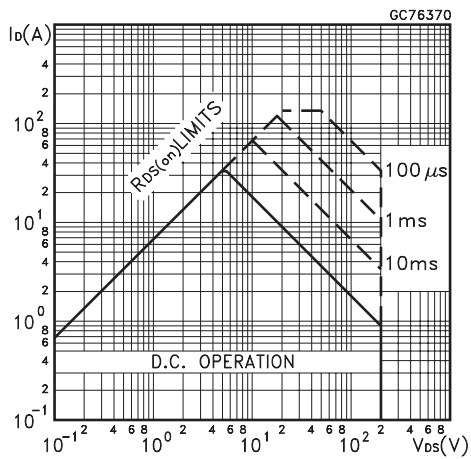

Figure 4. Thermal Impedance

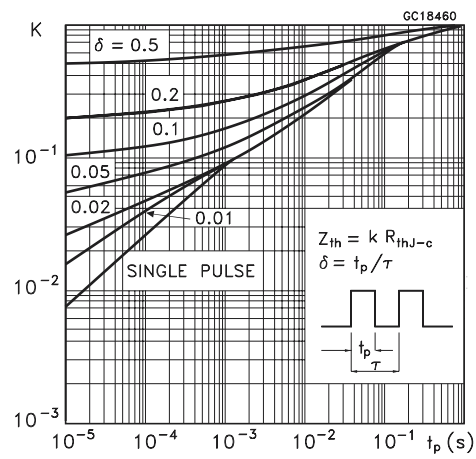

Figure 5. Output Characteristics

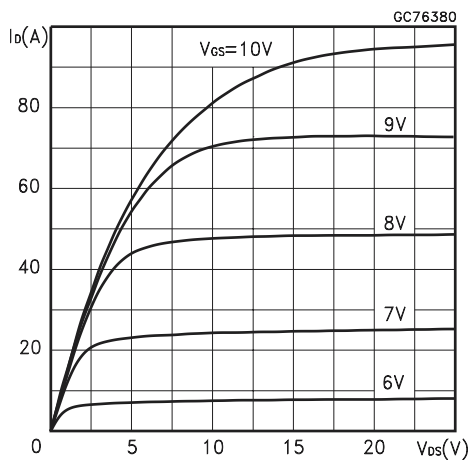

Figure 6. Transfer Characteristics

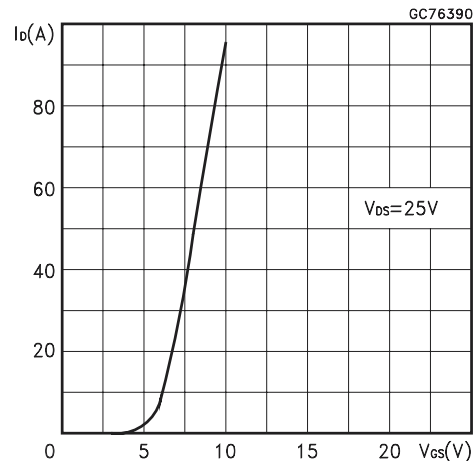

Figure 7. Transconductance

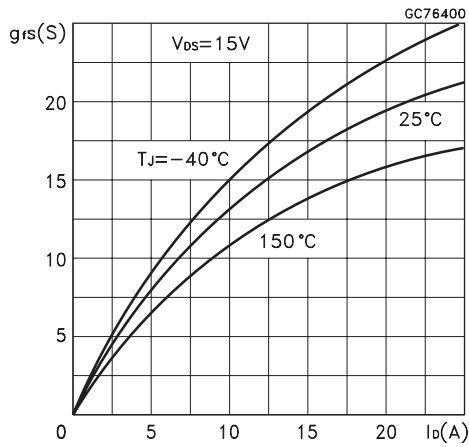

Figure 8. Static Drain-source On Resistance

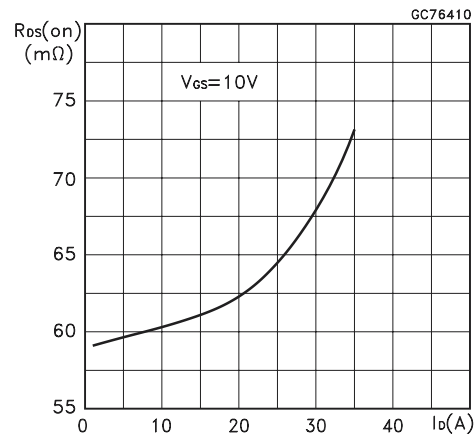

Figure 9. Gate Charge vs Gate-source Voltage

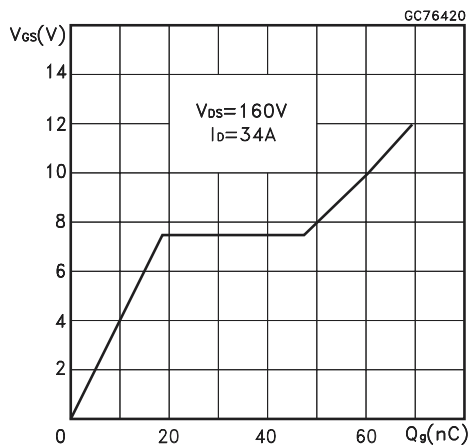

Figure 10. Capacitance Variations

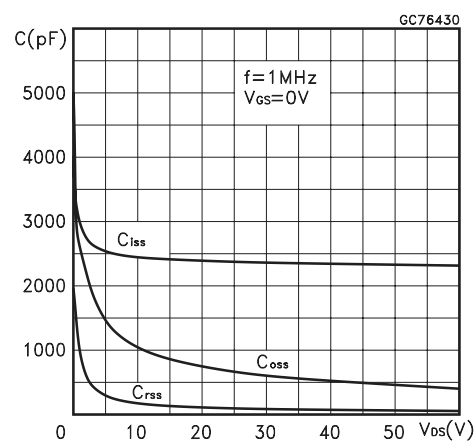

Figure 11. Normalized Gate Threshold Voltage vs Temperature

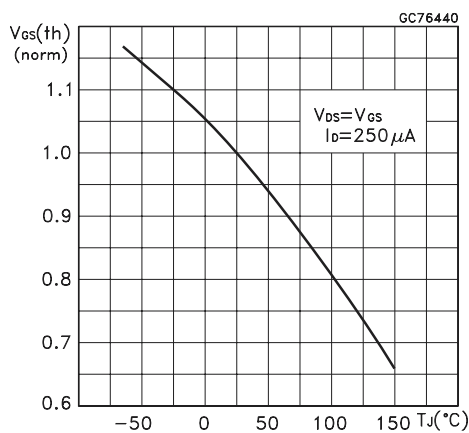
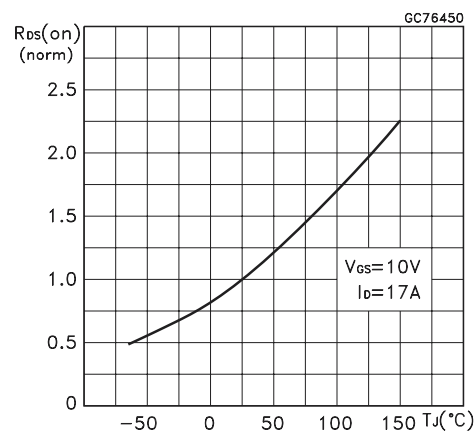
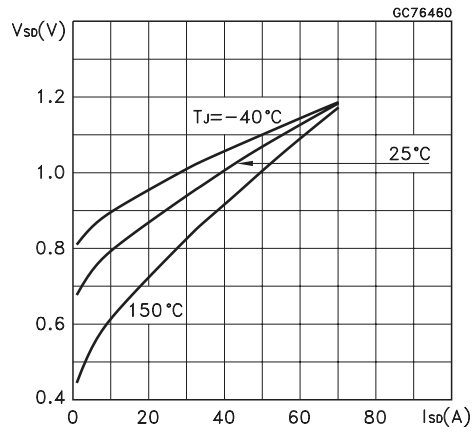

Figure 12. Normalized On Resistance vs Temperature



**Figure 13. Source-drain Diode Forward Characteristics**



**Figure 14. Unclamped Inductive Load Test Circuit**

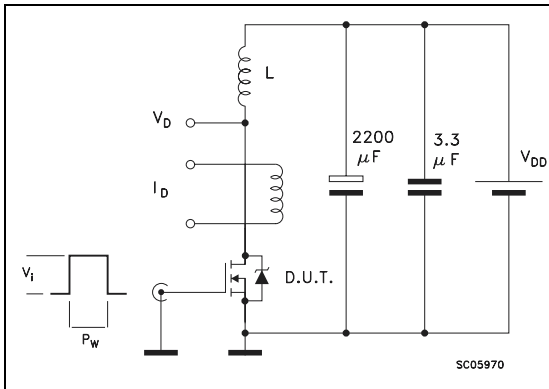

**Figure 15. Unclamped Inductive Waveforms**

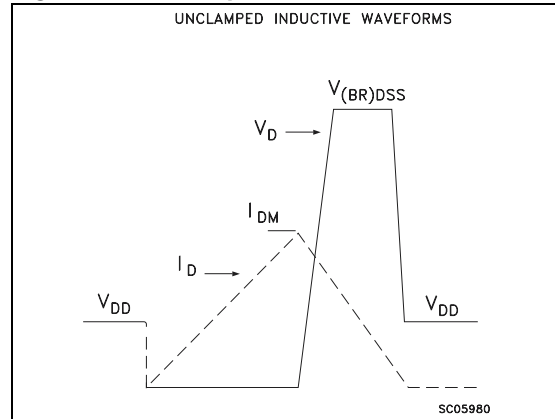

**Figure 16. Switching Times Test Circuits For Resistive Load**

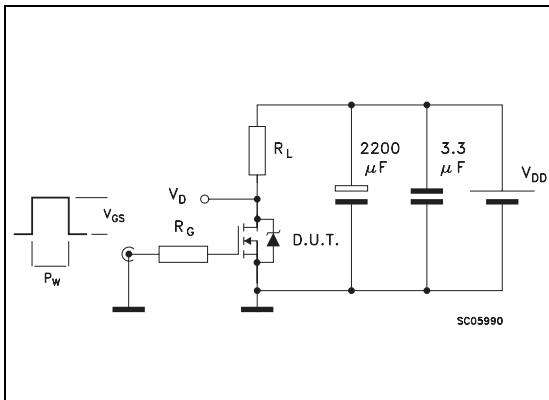

**Figure 17. Gate Charge Test Circuit**

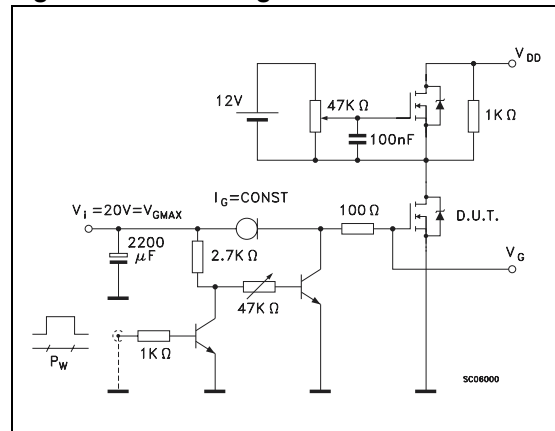

**Figure 18. Test Circuit For Inductive Load Switching And Diode Recovery Times**

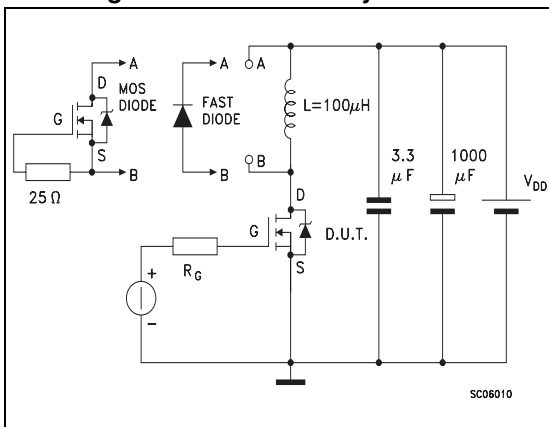

# STW34NB20

## PACKAGE MECHANICAL

Table 12. TO-247 Mechanical Data

Symbol	millimeters			inches		
	Min	Typ	Max	Min	Typ	Max
A	4.85		5.15	0.19		0.20
A1	2.20		2.60	0.086		0.102
b	1.0		1.40	0.039		0.055
b1	2.0		2.40	0.079		0.094
b2	3.0		3.40	0.118		0.134
c	0.40		0.80	0.015		0.03
D	19.85		20.15	0.781		0.793
E	15.45		15.75	0.608		0.620
e		5.45			0.214	
L	14.20		14.80	0.560		0.582
L1	3.70		4.30	0.14		0.17
L2		18.50			0.728	
ØP	3.55		3.65	0.140		0.143
ØR	4.50		5.50	0.177		0.216
S		5.50			0.216	

Figure 19. TO-247 Package Dimensions

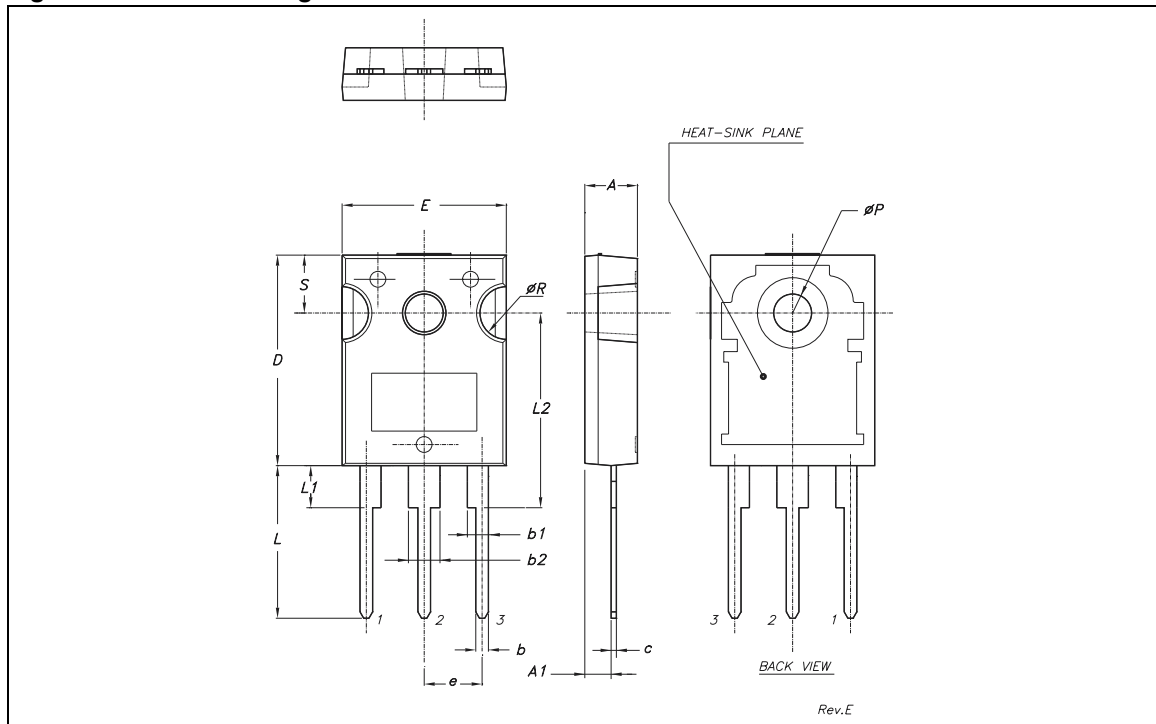

Note: Drawing is not to scale.



---

**REVISION HISTORY****Table 13. Revision History**

<b>Date</b>	<b>Revision</b>	<b>Description of Changes</b>
January-1998	1	First Issue
14-Apr-2004	2	Stylesheet update. No content change.

Information furnished is believed to be accurate and reliable. However, STMicroelectronics assumes no responsibility for the consequences of use of such information nor for any infringement of patents or other rights of third parties which may result from its use. No license is granted by implication or otherwise under any patent or patent rights of STMicroelectronics. Specifications mentioned in this publication are subject to change without notice. This publication supersedes and replaces all information previously supplied. STMicroelectronics products are not authorized for use as critical components in life support devices or systems without express written approval of STMicroelectronics.

The ST logo is a registered trademark of STMicroelectronics.  
All other names are the property of their respective owners

© 2004 STMicroelectronics - All rights reserved

STMicroelectronics GROUP OF COMPANIES

Australia - Belgium - Brazil - Canada - China - Czech Republic - Finland - France - Germany - Hong Kong - India - Israel - Italy - Japan -  
Malaysia - Malta - Morocco - Singapore - Spain - Sweden - Switzerland - United Kingdom - United States

[www.st.com](http://www.st.com)