



STB60N55F3, STD60N55F3, STF60N55F3 STI60N55F3, STP60N55F3, STU60N55F3

N-channel 55 V, 6.5 mΩ, 80 A, DPAK, IPAK, D²PAK, I²PAK, TO-220
TO-220FP S^TripFET™ III Power MOSFET

Features

Type	V _{DSS}	R _{DS(on)}	I _D	P _w
STB60N55F3	55V	<8.5mΩ	80A	110W
STD60N55F3	55V	<8.5mΩ	80A	110W
STF60N55F3	55V	<8.5mΩ	42A	30W
STI60N55F3	55V	<8.5mΩ	80A	110W
STP60N55F3	55V	<8.5mΩ	80A	110W
STU60N55F3	55V	<8.5mΩ	80A	110W

- Standard threshold drive
- 100% avalanche tested

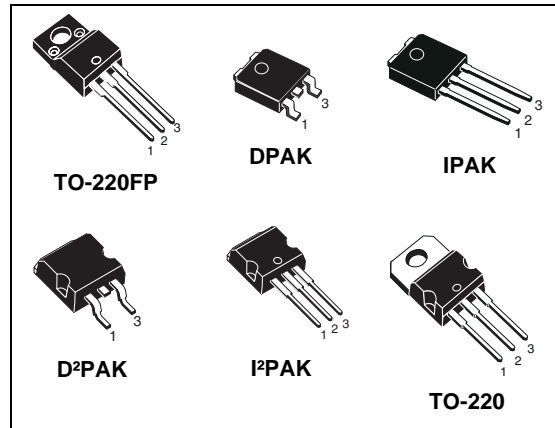

Application

- Switching applications

Description

This S^TripFET™ III Power MOSFET technology is among the latest improvements, which have been especially tailored to minimize on-state resistance providing superior switching performances.

Figure 1. Internal schematic diagram

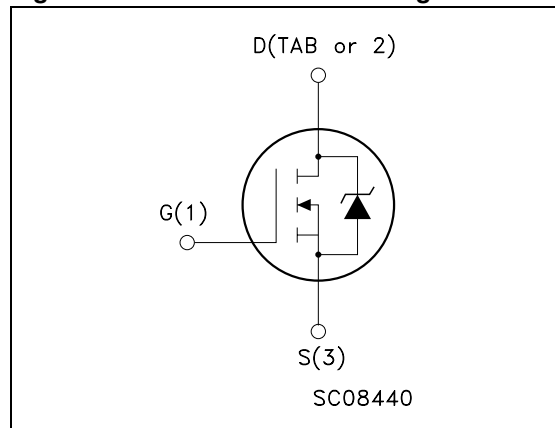

Table 1. Device summary

Order codes	Marking	Package	Packaging
STB60N55F3	60N55F3	D ² PAK	Tape and reel
STD60N55F3	60N55F3	DPAK	Tape and reel
STF60N55F3	60N55F3	TO-220FP	Tube
STI60N55F3	60N55F3	I ² PAK	Tube
STP60N55F3	60N55F3	TO-220	Tube
STU60N55F3	60N55F3	IPAK	Tube

Contents

1	Electrical ratings	3
2	Electrical characteristics	4
	2.1 Electrical characteristics (curves)	6
3	Test circuits	9
4	Package mechanical data	10
5	Packaging mechanical data	17
6	Revision history	19

1 Electrical ratings

Table 2. Absolute maximum ratings

Symbol	Parameter	Value		Unit
		DPAK/D ² PAK TO-220 IPAK/I ² PAK	TO-220FP	
V _{DS}	Drain-source voltage (V _{GS} =0)	55		V
V _{GS}	Gate-source voltage	± 20		V
I _D	Drain current (continuous) at T _C = 25°C	80	42	A
I _D	Drain current (continuous) at T _C = 100°C	56	30	A
I _{DM} ⁽¹⁾	Drain current (pulsed)	320	168	A
P _{TOT}	Total dissipation at T _C = 25°C	110	30	W
	Derating factor	0.73	0.2	W/°C
dv/dt ⁽²⁾	Peak diode recovery voltage slope	11		V/ns
E _{AS} ⁽³⁾	Single pulse avalanche energy	390		mJ
V _{ISO}	Insulation withstand voltage (RMS) from all three leads to external heat sink (t=1s; T _C =25°C)		2500	V
T _j T _{stg}	Operating junction temperature Storage temperature	-55 to 175		°C

1. Pulse width limited by safe operating area
2. I_{SD} ≤ 80 A, di/dt ≤ 300A/μs, V_{DD} ≤ V_{(BR)DSS}. T_j ≤ T_{jmax}
3. Starting T_j=25°C, I_d=32 A, V_{dd}= 25 V

Table 3. Thermal resistance

Symbol	Parameter	Value					Unit
		DPAK	IPAK I ² PAK	D ² PAK	TO-220	TO-220FP	
R _{thj-case}	Thermal resistance junction-case max	1.36			5	°C/W	
R _{thj-pcb} ⁽¹⁾	Thermal resistance junction-pcb max	50		35		°C/W	
R _{thj-a}	Thermal resistance junction-ambient max		100		62.5	°C/W	
T _l	Maximum lead temperature for soldering purpose		275		300	°C	

1. When mounted on FR-4 board of 1inch², 2oz Cu

2 Electrical characteristics

($T_{CASE} = 25\text{ °C}$ unless otherwise specified)

Table 4. Static

Symbol	Parameter	Test conditions	Min.	Typ.	Max.	Unit
$V_{(BR)DSS}$	Drain-source breakdown voltage	$I_D = 250\mu\text{A}$, $V_{GS} = 0$	55			V
I_{DSS}	Zero gate voltage drain current ($V_{GS} = 0$)	$V_{DS} = \text{Max rating}$, $V_{DS} = \text{Max rating}$, $T_c = 125\text{ °C}$			10 100	μA μA
I_{GSS}	Gate body leakage current ($V_{DS} = 0$)	$V_{GS} = \pm 20\text{V}$			± 200	nA
$V_{GS(th)}$	Gate threshold voltage	$V_{DS} = V_{GS}$, $I_D = 250\mu\text{A}$	2		4	V
$R_{DS(on)}$	Static drain-source on resistance	$V_{GS} = 10\text{V}$, $I_D = 32\text{A}$		6.5	8.5	$\text{m}\Omega$

Table 5. Dynamic

Symbol	Parameter	Test conditions	Min.	Typ.	Max.	Unit
$g_{fs}^{(1)}$	Forward transconductance	$V_{DS} = 25\text{V}$, $I_D = 32\text{A}$	-	50		S
C_{iss}	Input capacitance	$V_{DS} = 25\text{V}$, $f = 1\text{MHz}$, $V_{GS} = 0$	-	2200		pF
C_{oss}	Output capacitance			500		pF
C_{rss}	Reverse transfer capacitance			25		pF
Q_g	Total gate charge	$V_{DD} = 27\text{V}$, $I_D = 65\text{A}$	-	33.5	45	nC
Q_{gs}	Gate-source charge	$V_{GS} = 10\text{V}$		12.5		nC
Q_{gd}	Gate-drain charge	(see Figure 16)		9.5		nC

1. Pulsed: pulse duration = 300 μs , duty cycle 1.5%

Table 6. Switching on/off (inductive load)

Symbol	Parameter	Test conditions	Min.	Typ.	Max.	Unit
$t_{d(on)}$	Turn-on delay time	$V_{DD} = 27\text{V}$, $I_D = 32\text{A}$, $R_G = 4.7\Omega$, $V_{GS} = 10\text{V}$ (see Figure 18)	-	20	-	ns
t_r	Rise time			50	-	ns
$t_{d(off)}$	Turn-off delay time	$V_{DD} = 27\text{V}$, $I_D = 32\text{A}$, $R_G = 4.7\Omega$, $V_{GS} = 10\text{V}$ (see Figure 18)	-	35	-	ns
t_f	Fall time			11.5	-	ns

Table 7. Source drain diode

Symbol	Parameter	Test conditions	Packages	Min.	Typ.	Max.	Unit
I_{SD} $I_{SDM}^{(1)}$	Source-drain current Source-drain current (pulsed)		DPAK-D ² PAK- I ² PAK-I ² PAK- TO-220	-		80 320	A A
I_{SD} $I_{SDM}^{(1)}$	Source-drain current Source-drain current (pulsed)		TO-220FP	-		42 168	A A
V_{SD}	Forward on voltage	$I_{SD} = 65A, V_{GS} = 0$		-		1.5	V
t_{rr} Q_{rr} I_{RRM}	Reverse recovery time Reverse recovery charge Reverse recovery current	$I_{SD} = 65A, V_{DD} = 30V$ $di/dt = 100A/\mu s,$ $T_j = 150^\circ C$ <i>(see Figure 17)</i>		-	47 87 3.7		ns nC A

1. Pulsed: pulse duration = 300 μs , duty cycle 1.5%

2.1 Electrical characteristics (curves)

Figure 2. Safe operating area for TO-220
D²PAK / I²PAK / I²PAK / DPAK

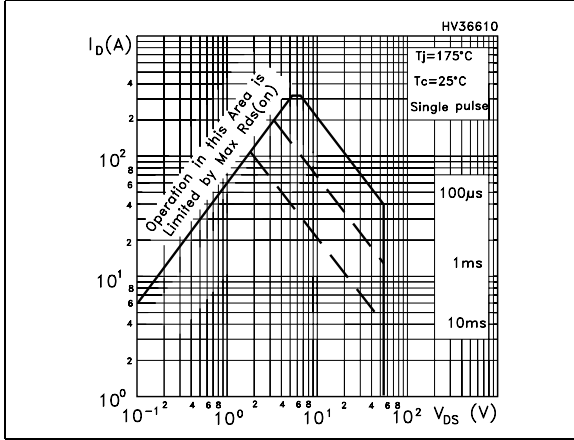

Figure 3. Thermal impedance for TO-220
D²PAK / I²PAK / I²PAK / DPAK

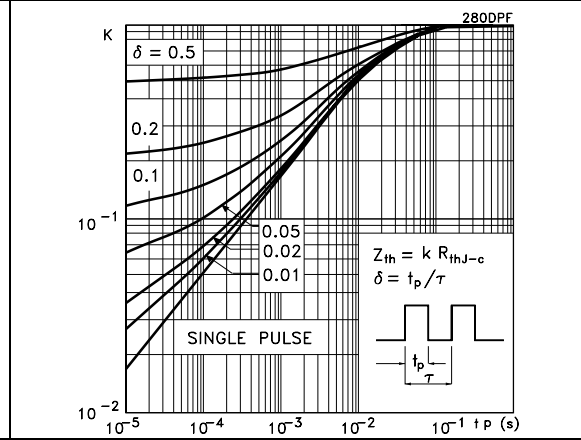

Figure 4. Safe operating area for TO-220FP

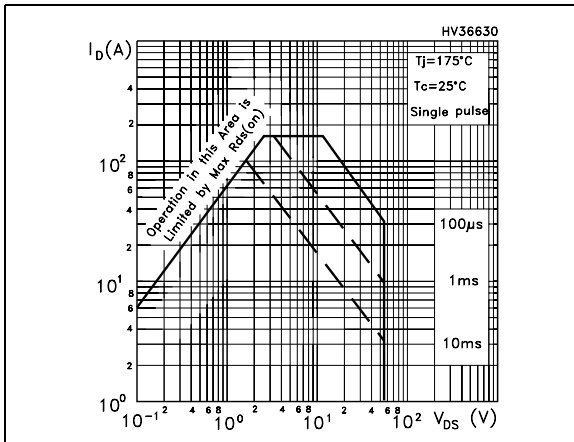

Figure 5. Thermal impedance for TO-220FP

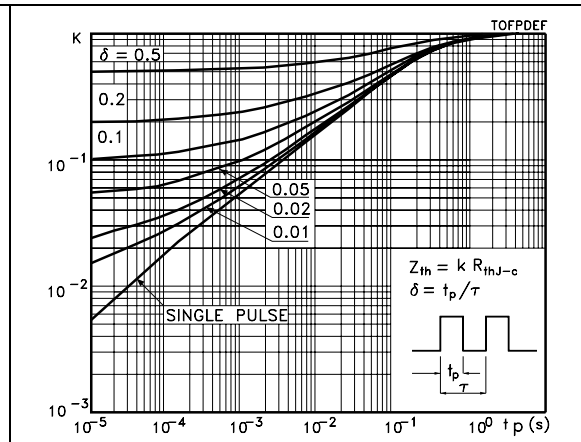

Figure 6. Output characteristics

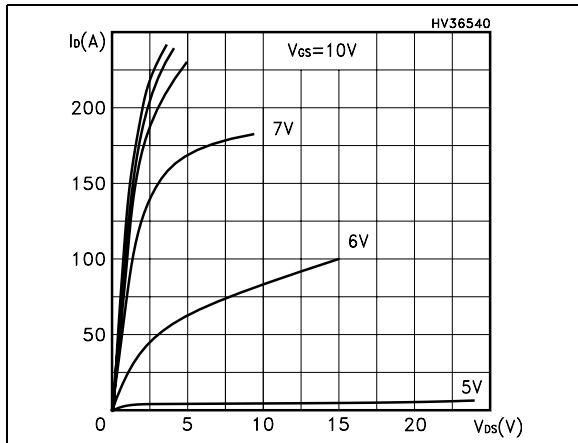

Figure 7. Transfer characteristics

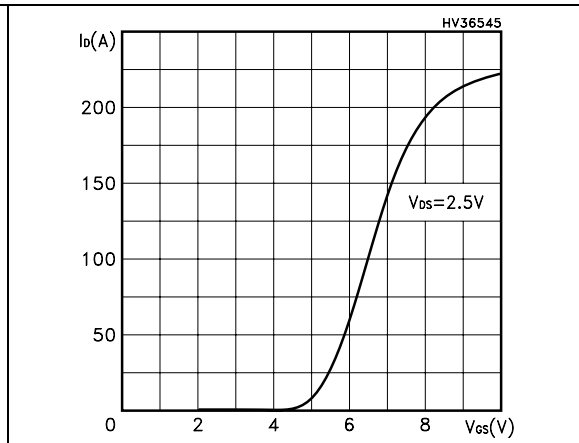

Figure 8. Normalized BV_{DSS} vs temperature

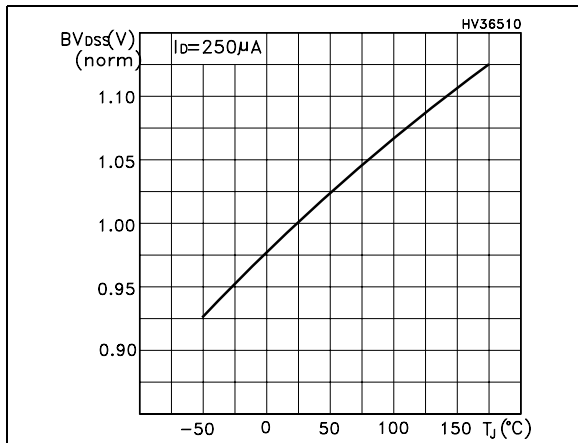

Figure 9. Static drain-source on resistance

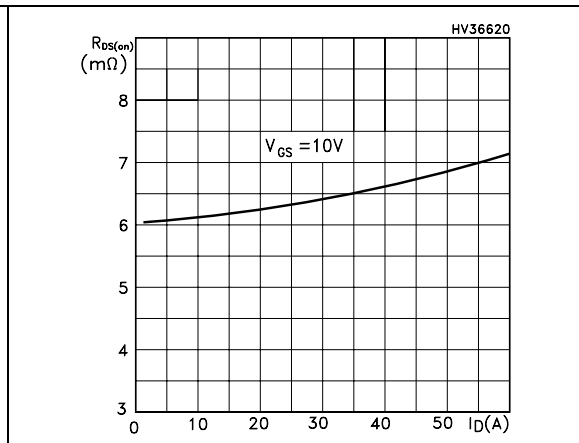

Figure 10. Gate charge vs gate-source voltage Figure 11. Capacitance variations

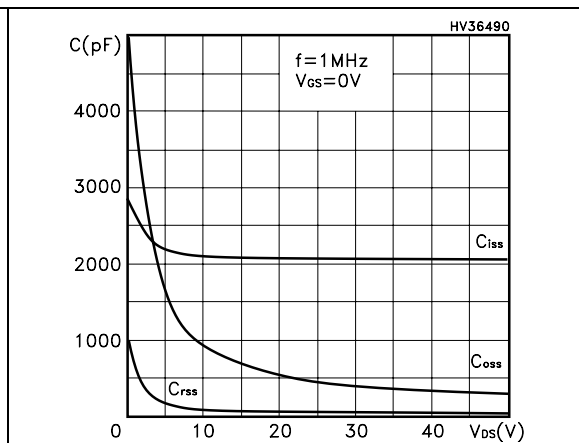
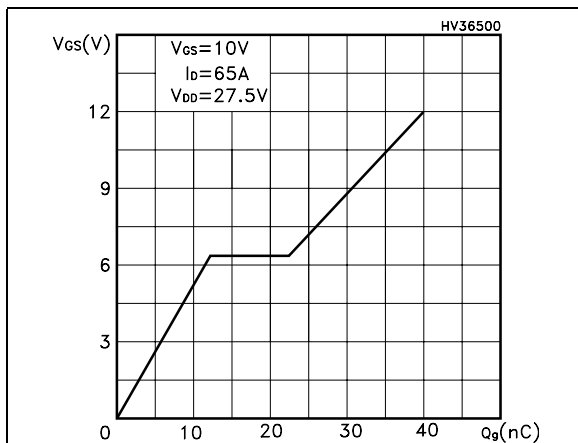

Figure 12. Normalized gate threshold voltage vs temperature

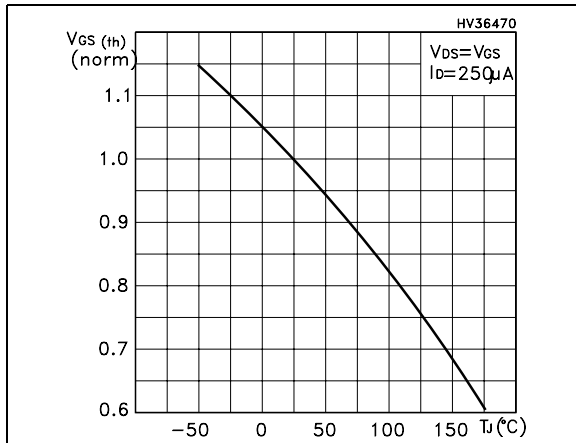

Figure 13. Normalized on resistance vs temperature

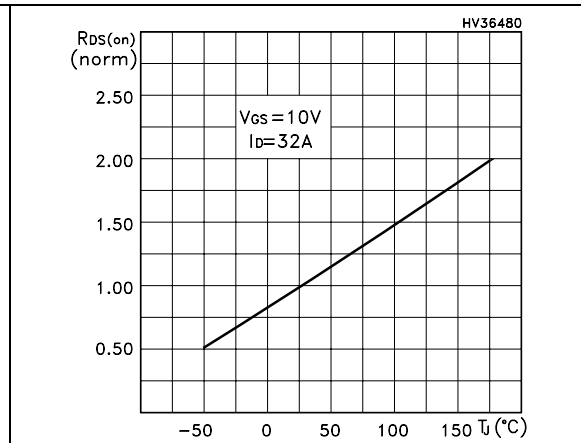
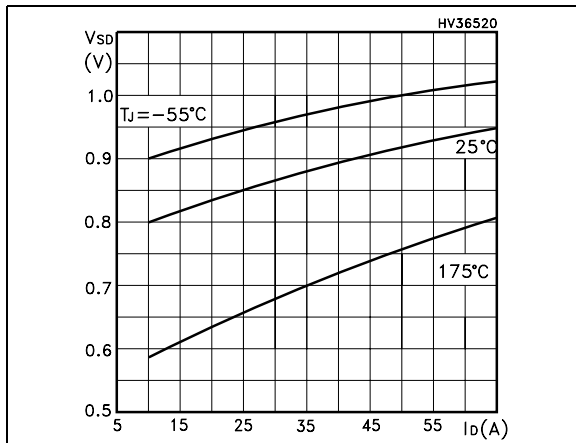

Figure 14. Source-drain diode forward characteristics



3 Test circuits

Figure 15. Switching times test circuit for resistive load

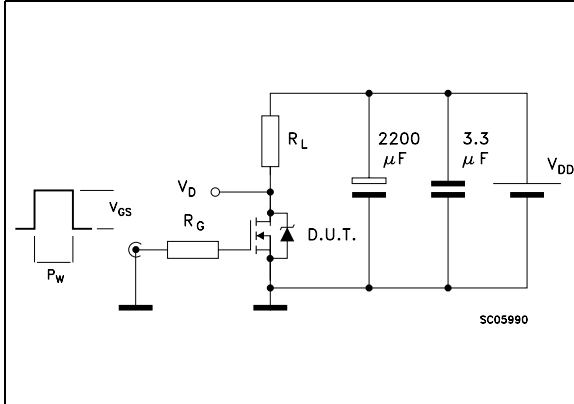

Figure 16. Gate charge test circuit

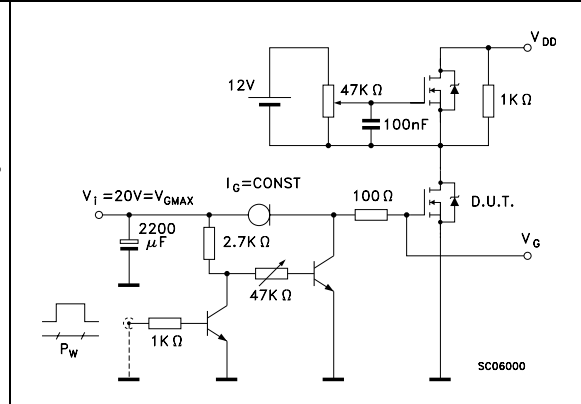

Figure 17. Test circuit for inductive load switching and diode recovery times

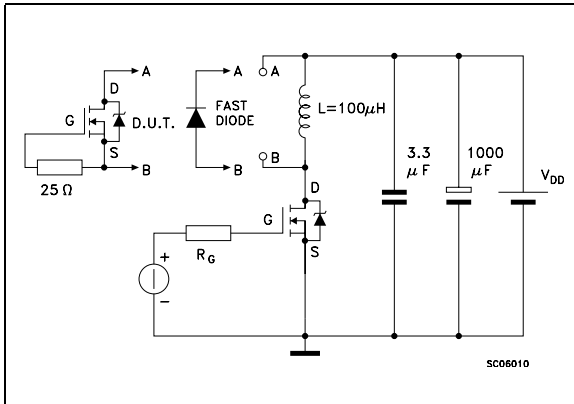

Figure 18. Unclamped inductive load test circuit

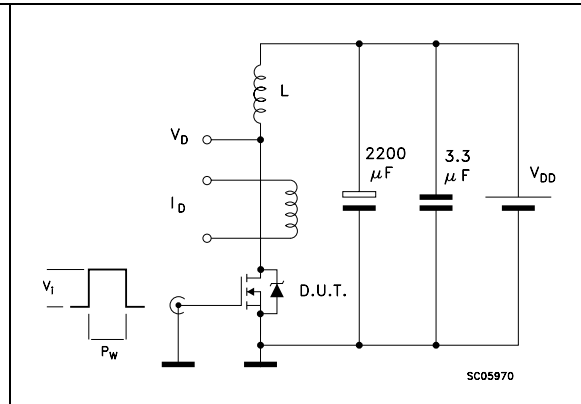

Figure 19. Unclamped inductive waveform

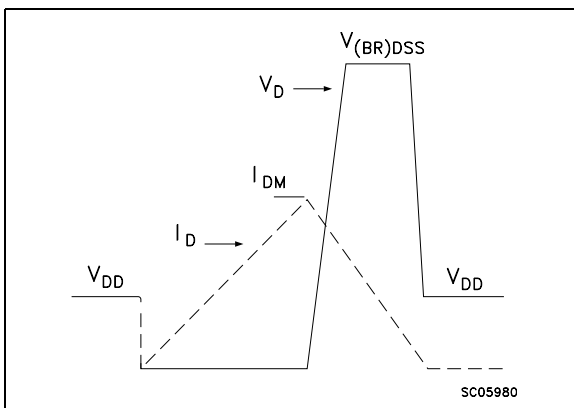
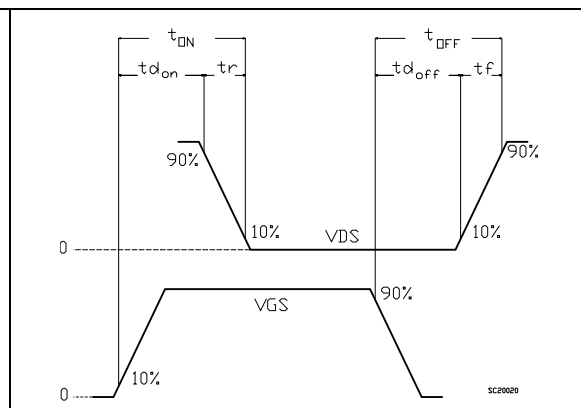

Figure 20. Switching time waveform



4 Package mechanical data

In order to meet environmental requirements, ST offers these devices in different grades of ECOPACK[®] packages, depending on their level of environmental compliance. ECOPACK[®] specifications, grade definitions and product status are available at: www.st.com. ECOPACK is an ST trademark.

I²PAK (TO-262) mechanical data

Dim	mm			inch		
	Min	Typ	Max	Min	Typ	Max
A	4.40		4.60	0.173		0.181
A1	2.40		2.72	0.094		0.107
b	0.61		0.88	0.024		0.034
b1	1.14		1.70	0.044		0.066
c	0.49		0.70	0.019		0.027
c2	1.23		1.32	0.048		0.052
D	8.95		9.35	0.352		0.368
e	2.40		2.70	0.094		0.106
e1	4.95		5.15	0.194		0.202
E	10		10.40	0.393		0.410
L	13		14	0.511		0.551
L1	3.50		3.93	0.137		0.154
L2	1.27		1.40	0.050		0.055

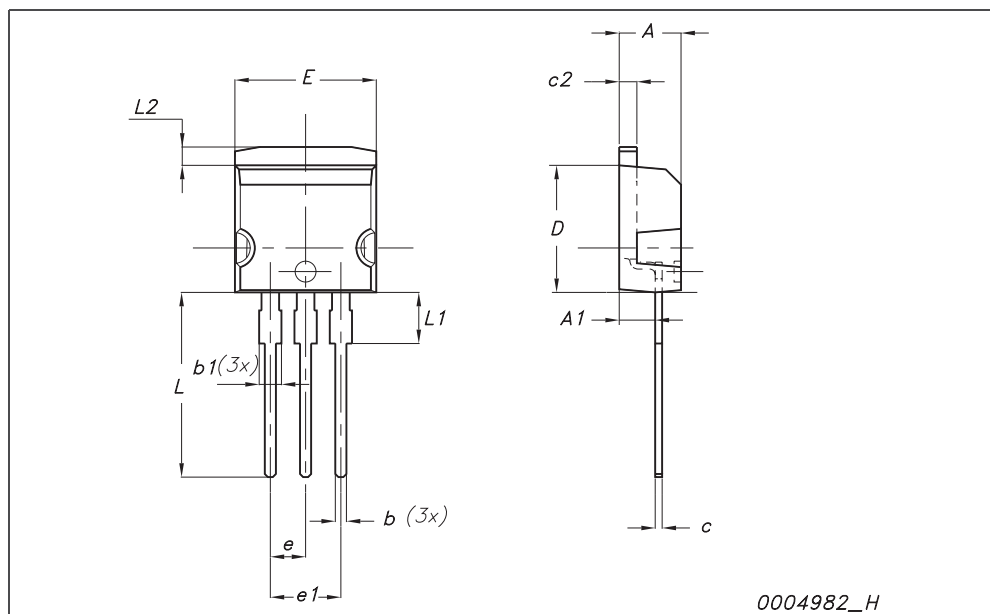

D²PAK (TO-263) mechanical data

Dim	mm			inch		
	Min	Typ	Max	Min	Typ	Max
A	4.40		4.60	0.173		0.181
A1	0.03		0.23	0.001		0.009
b	0.70		0.93	0.027		0.037
b2	1.14		1.70	0.045		0.067
c	0.45		0.60	0.017		0.024
c2	1.23		1.36	0.048		0.053
D	8.95		9.35	0.352		0.368
D1	7.50			0.295		
E	10		10.40	0.394		0.409
E1	8.50			0.334		
e		2.54			0.1	
e1	4.88		5.28	0.192		0.208
H	15		15.85	0.590		0.624
J1	2.49		2.69	0.099		0.106
L	2.29		2.79	0.090		0.110
L1	1.27		1.40	0.05		0.055
L2	1.30		1.75	0.051		0.069
R		0.4			0.016	
V2	0°		8°	0°		8°

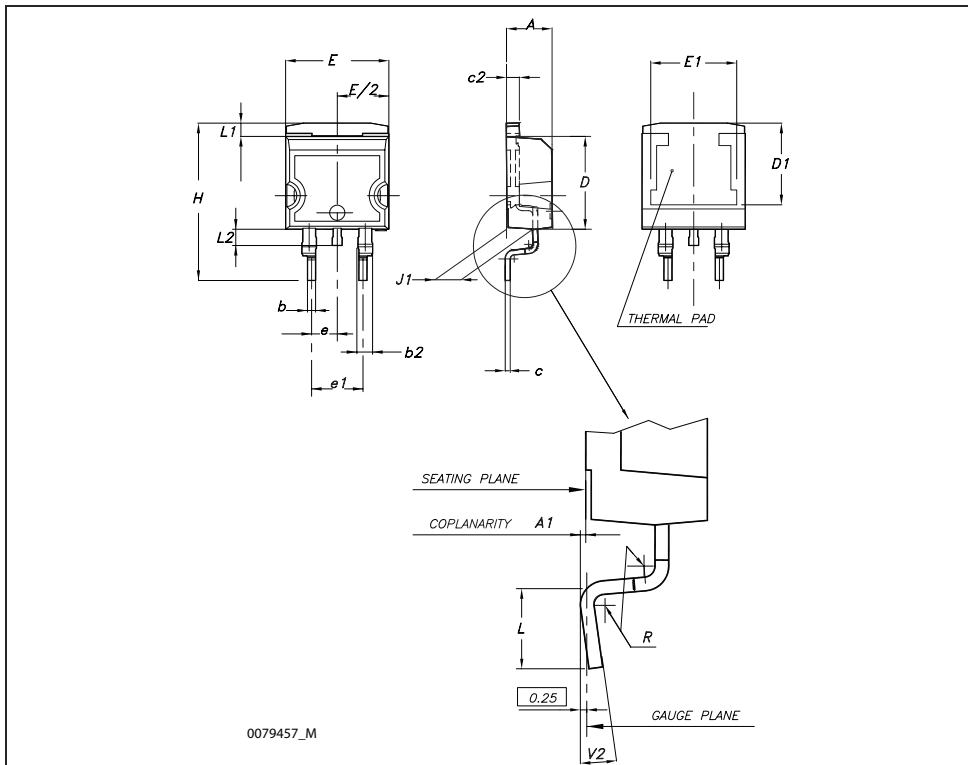

TO-252 (DPAK) mechanical data

DIM.	mm.		
	min.	typ	max.
A	2.20		2.40
A1	0.90		1.10
A2	0.03		0.23
b	0.64		0.90
b4	5.20		5.40
c	0.45		0.60
c2	0.48		0.60
D	6.00		6.20
D1		5.10	
E	6.40		6.60
E1		4.70	
e		2.28	
e1	4.40		4.60
H	9.35		10.10
L	1		
L1		2.80	
L2		0.80	
L4	0.60		1
R		0.20	
V2	0°		8°

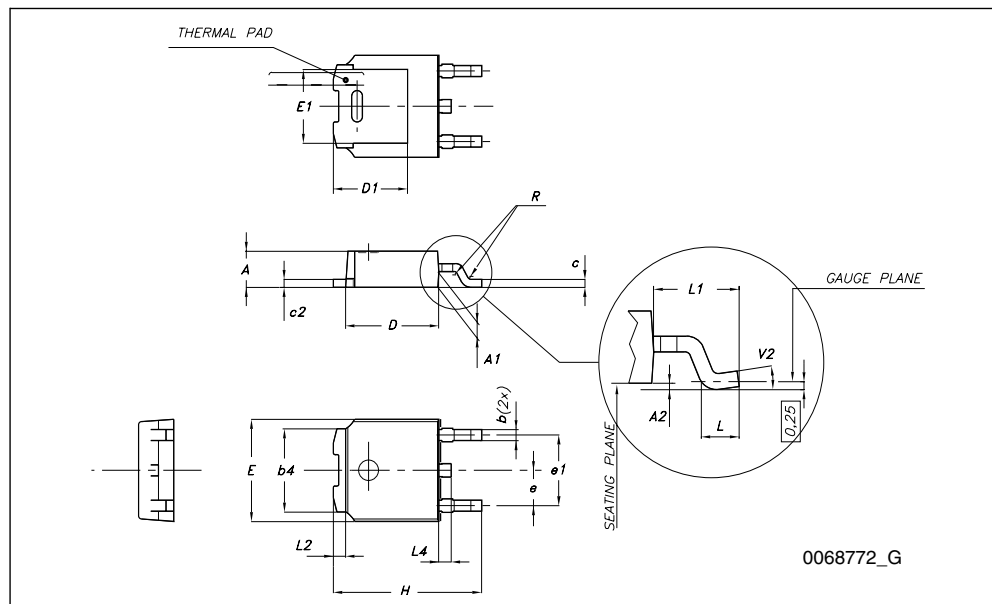

TO-251 (IPAK) mechanical data

DIM.	mm.		
	min.	typ	max.
A	2.20		2.40
A1	0.90		1.10
b	0.64		0.90
b2			0.95
b4	5.20		5.40
c	0.45		0.60
c2	0.48		0.60
D	6.00		6.20
E	6.40		6.60
e		2.28	
e1	4.40		4.60
H		16.10	
L	9.00		9.40
(L1)	0.80		1.20
L2		0.80	
V1		10°	

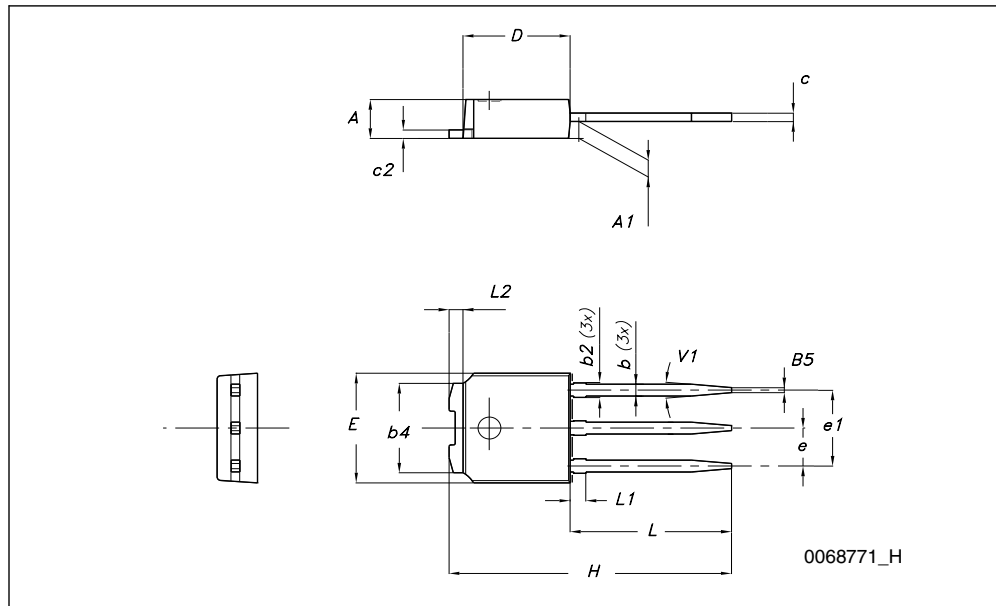

TO-220 mechanical data

Dim	mm			inch		
	Min	Typ	Max	Min	Typ	Max
A	4.40		4.60	0.173		0.181
b	0.61		0.88	0.024		0.034
b1	1.14		1.70	0.044		0.066
c	0.48		0.70	0.019		0.027
D	15.25		15.75	0.6		0.62
D1		1.27			0.050	
E	10		10.40	0.393		0.409
e	2.40		2.70	0.094		0.106
e1	4.95		5.15	0.194		0.202
F	1.23		1.32	0.048		0.051
H1	6.20		6.60	0.244		0.256
J1	2.40		2.72	0.094		0.107
L	13		14	0.511		0.551
L1	3.50		3.93	0.137		0.154
L20		16.40			0.645	
L30		28.90			1.137	
∅P	3.75		3.85	0.147		0.151
Q	2.65		2.95	0.104		0.116

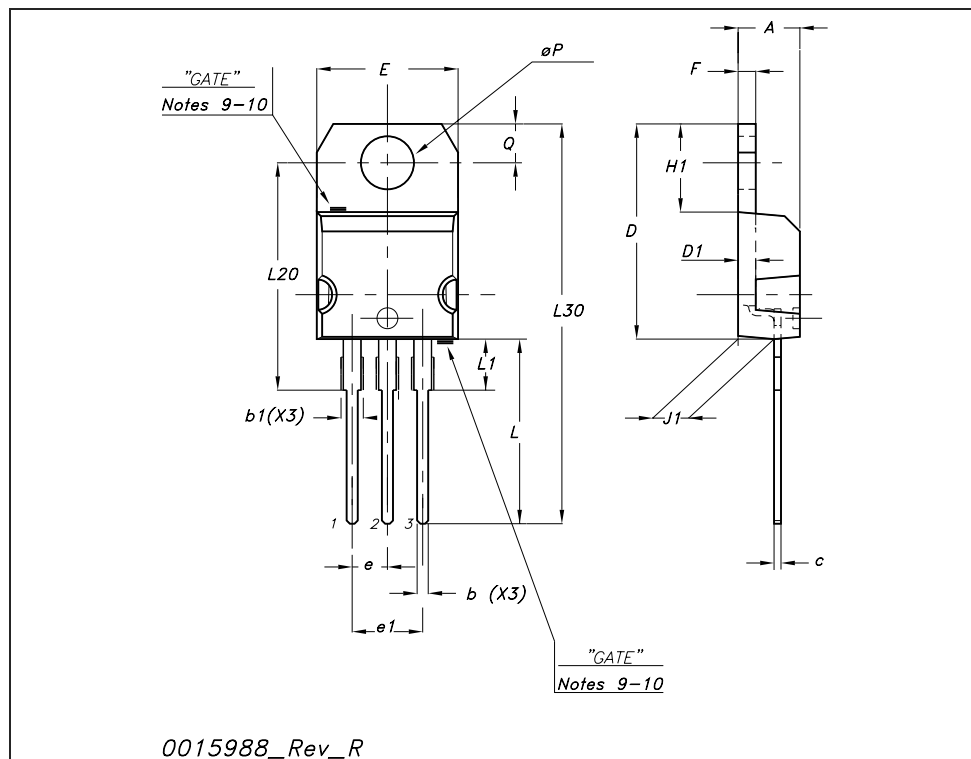

TO-220FP mechanical data

Dim.	mm		
	Min.	Typ.	Max.
A	4.4		4.6
B	2.5		2.7
D	2.5		2.75
E	0.45		0.7
F	0.75		1
F1	1.15		1.70
F2	1.15		1.5
G	4.95		5.2
G1	2.4		2.7
H	10		10.4
L2		16	
L3	28.6		30.6
L4	9.8		10.6
L5	2.9		3.6
L6	15.9		16.4
L7	9		9.3
Dia	3		3.2

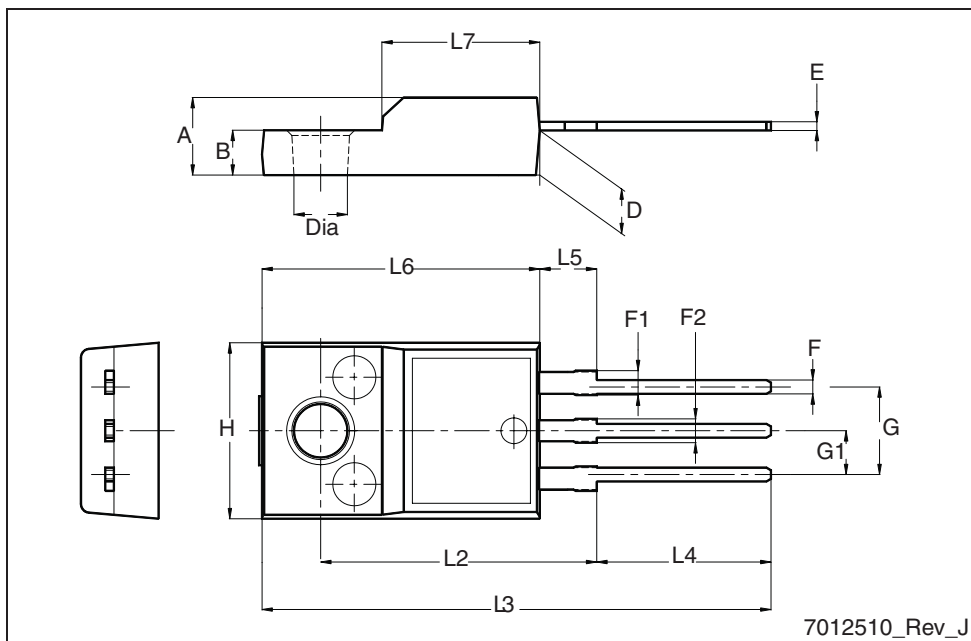

7012510_Rev_J

5 Packaging mechanical data

DPAK FOOTPRINT

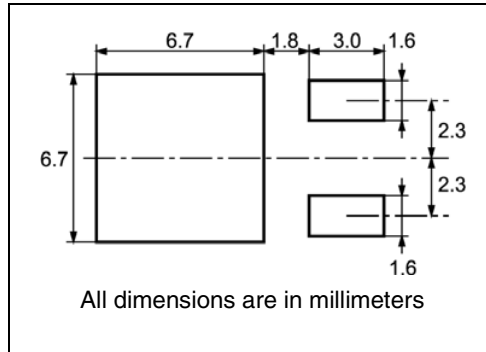

TAPE AND REEL SHIPMENT

REEL MECHANICAL DATA

DIM.	mm		inch	
	MIN.	MAX.	MIN.	MAX.
A		330		12.992
B	1.5		0.059	
C	12.8	13.2	0.504	0.520
D	20.2		0.795	
G	16.4	18.4	0.645	0.724
N	50		1.968	
T		22.4		0.881

TAPE MECHANICAL DATA

DIM.	mm		inch	
	MIN.	MAX.	MIN.	MAX.
A0	6.8	7	0.267	0.275
B0	10.4	10.6	0.409	0.417
B1		12.1		0.476
D	1.5	1.6	0.059	0.063
D1	1.5		0.059	
E	1.65	1.85	0.065	0.073
F	7.4	7.6	0.291	0.299
K0	2.55	2.75	0.100	0.108
P0	3.9	4.1	0.153	0.161
P1	7.9	8.1	0.311	0.319
P2	1.9	2.1	0.075	0.082
R	40		1.574	
W	15.7	16.3	0.618	0.641

For machine ref. only including draft and radii concentric around B0

10 pitches cumulative tolerance on tape +/- 0.2 mm

D²PAK FOOTPRINT

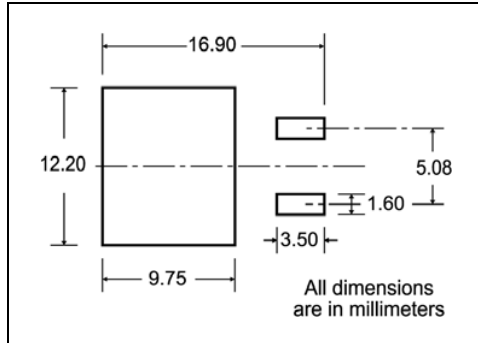

TAPE AND REEL SHIPMENT

TAPE MECHANICAL DATA

DIM.	mm		inch	
	MIN.	MAX.	MIN.	MAX.
A0	10.5	10.7	0.413	0.421
B0	15.7	15.9	0.618	0.626
D	1.5	1.6	0.059	0.063
D1	1.59	1.61	0.062	0.063
E	1.65	1.85	0.065	0.073
F	11.4	11.6	0.449	0.456
K0	4.8	5.0	0.189	0.197
P0	3.9	4.1	0.153	0.161
P1	11.9	12.1	0.468	0.476
P2	1.9	2.1	0.075	0.082
R	50		1.574	
T	0.25	0.35	0.0098	0.0137
W	23.7	24.3	0.933	0.956

REEL MECHANICAL DATA

DIM.	mm		inch	
	MIN.	MAX.	MIN.	MAX.
A		330		12.992
B	1.5		0.059	
C	12.8	13.2	0.504	0.520
D	20.2		0.795	
G	24.4	26.4	0.960	1.039
N	100		3.937	
T		30.4		1.197

BASE QTY	BULK QTY
1000	1000

10 pitches cumulative tolerance on tape + / - 0.2 mm

* on sales type

6 Revision history

Table 8. Document revision history

Date	Revision	Changes
09-Feb-2007	1	First release
22-Feb-2007	2	Description has been updated
07-Mar-2007	3	The Figure 2 , Figure 4 , Figure 9 have been changed
17-Apr-2009	4	Added device in I ² PAK Updated all mechanical data

Please Read Carefully:

Information in this document is provided solely in connection with ST products. STMicroelectronics NV and its subsidiaries ("ST") reserve the right to make changes, corrections, modifications or improvements, to this document, and the products and services described herein at any time, without notice.

All ST products are sold pursuant to ST's terms and conditions of sale.

Purchasers are solely responsible for the choice, selection and use of the ST products and services described herein, and ST assumes no liability whatsoever relating to the choice, selection or use of the ST products and services described herein.

No license, express or implied, by estoppel or otherwise, to any intellectual property rights is granted under this document. If any part of this document refers to any third party products or services it shall not be deemed a license grant by ST for the use of such third party products or services, or any intellectual property contained therein or considered as a warranty covering the use in any manner whatsoever of such third party products or services or any intellectual property contained therein.

UNLESS OTHERWISE SET FORTH IN ST'S TERMS AND CONDITIONS OF SALE ST DISCLAIMS ANY EXPRESS OR IMPLIED WARRANTY WITH RESPECT TO THE USE AND/OR SALE OF ST PRODUCTS INCLUDING WITHOUT LIMITATION IMPLIED WARRANTIES OF MERCHANTABILITY, FITNESS FOR A PARTICULAR PURPOSE (AND THEIR EQUIVALENTS UNDER THE LAWS OF ANY JURISDICTION), OR INFRINGEMENT OF ANY PATENT, COPYRIGHT OR OTHER INTELLECTUAL PROPERTY RIGHT.

UNLESS EXPRESSLY APPROVED IN WRITING BY AN AUTHORIZED ST REPRESENTATIVE, ST PRODUCTS ARE NOT RECOMMENDED, AUTHORIZED OR WARRANTED FOR USE IN MILITARY, AIR CRAFT, SPACE, LIFE SAVING, OR LIFE SUSTAINING APPLICATIONS, NOR IN PRODUCTS OR SYSTEMS WHERE FAILURE OR MALFUNCTION MAY RESULT IN PERSONAL INJURY, DEATH, OR SEVERE PROPERTY OR ENVIRONMENTAL DAMAGE. ST PRODUCTS WHICH ARE NOT SPECIFIED AS "AUTOMOTIVE GRADE" MAY ONLY BE USED IN AUTOMOTIVE APPLICATIONS AT USER'S OWN RISK.

Resale of ST products with provisions different from the statements and/or technical features set forth in this document shall immediately void any warranty granted by ST for the ST product or service described herein and shall not create or extend in any manner whatsoever, any liability of ST.

ST and the ST logo are trademarks or registered trademarks of ST in various countries.

Information in this document supersedes and replaces all information previously supplied.

The ST logo is a registered trademark of STMicroelectronics. All other names are the property of their respective owners.

© 2009 STMicroelectronics - All rights reserved

STMicroelectronics group of companies

Australia - Belgium - Brazil - Canada - China - Czech Republic - Finland - France - Germany - Hong Kong - India - Israel - Italy - Japan - Malaysia - Malta - Morocco - Philippines - Singapore - Spain - Sweden - Switzerland - United Kingdom - United States of America

www.st.com