



STK22N6F3

N-channel 60 V, 0.0055 Ω , 22 A, PolarPAK[®]
STripFET[™] Power MOSFET

Features

Type	V _{DSS}	R _{DS(on)} max
STK22N6F3	60 V	< 0.006 Ω

- Ultra low top and bottom junction to case thermal resistance
- Extremely low on-resistance R_{DS(on)}
- Very low switching gate charge
- Fully encapsulated die
- 100% matte tin finish (in compliance with the 2002/95/EC european directive)
- High avalanche ruggedness
- PolarPAK[®] is a trademark of VISHAY

Application

- Switching applications

Description

This STripFET[™] III Power MOSFET technology is among the latest improvements, which have been especially tailored to minimize on-state resistance providing superior switching performances.

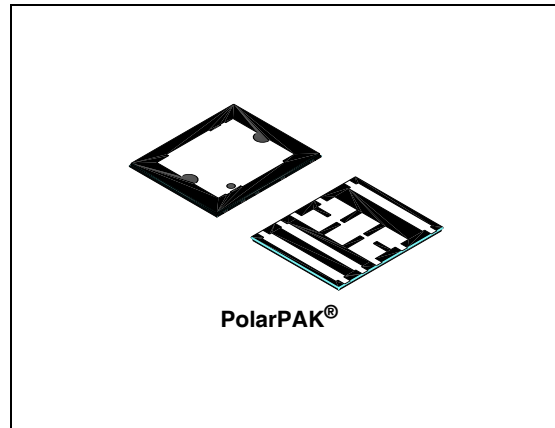

Figure 1. Internal schematic diagram

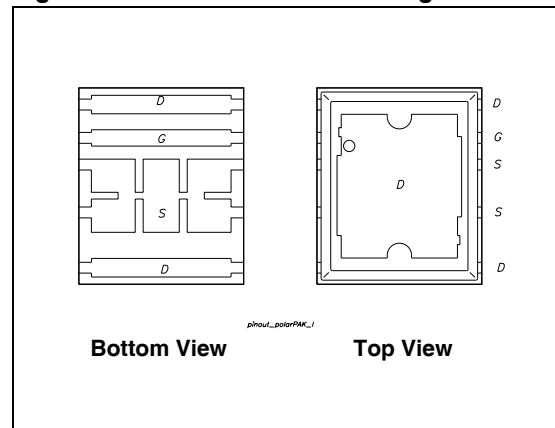

Table 1. Device summary

Order code	Marking	Package	Packaging
STK22N6F3	2263	PolarPAK [®]	Tape and reel

Contents

1	Electrical ratings	3
2	Electrical characteristics	4
	2.1 Electrical characteristics (curves)	6
3	Test circuits	8
4	Package mechanical data	10
5	Revision history	14

1 Electrical ratings

Table 2. Absolute maximum ratings

Symbol	Parameter	Value	Unit
V_{DS}	Drain-source voltage ($V_{GS} = 0$)	60	V
V_{GS}	Gate-source voltage	± 20	V
$I_D^{(1)}$	Drain current (continuous) at $T_C = 25^\circ\text{C}$	22	A
I_D	Drain current (continuous) at $T_C = 100^\circ\text{C}$	13.7	A
$I_{DM}^{(2)}$	Drain current (pulsed)	88	A
$P_{TOT}^{(1)}$	Total dissipation at $T_C = 25^\circ\text{C}$	5.2	W
	Derating factor	0.0416	W/ $^\circ\text{C}$
$E_{AS}^{(3)}$	Single pulse avalanche energy	800	mJ
T_j	Operating junction temperature	-55 to 150	$^\circ\text{C}$
T_{stg}	Storage temperature		

1. When mounted on FR-4 board of 1inch², 2 oz Cu and ≤ 10 sec
2. Pulse width limited by package
3. Starting $T_j = 25^\circ\text{C}$, $I_D = 11$ A, $V_{DD} = 48$ V

Table 3. Thermal data

Symbol	Parameter	Typ.	Max.	Unit
$R_{thj-amb}^{(1)}$	Thermal resistance junction-amb	20	24	$^\circ\text{C}/\text{W}$
$R_{thj-c}^{(2)}$	Thermal resistance junction-case (top drain)	0.8	1	$^\circ\text{C}/\text{W}$
$R_{thj-c}^{(3)}$	Thermal resistance junction-case (source)	2.2	2.7	$^\circ\text{C}/\text{W}$

1. When mounted on FR-4 board of 1inch², 2 oz Cu and ≤ 10 sec
2. Steady state
3. Measured at source pin when the device is mounted on FR-4 board in steady state

2 Electrical characteristics

($T_{CASE}=25\text{ °C}$ unless otherwise specified)

Table 4. On/off states

Symbol	Parameter	Test conditions	Min.	Typ.	Max.	Unit
$V_{(BR)DSS}$	Drain-source breakdown voltage	$I_D = 250\ \mu\text{A}$, $V_{GS} = 0$	60	-	-	V
I_{DSS}	Zero gate voltage drain current ($V_{GS} = 0$)	$V_{DS} = \text{Max rating}$, $V_{DS} = \text{Max rating}$, $T_C = 125\text{ °C}$	-	-	10 100	μA μA
I_{GSS}	Gate body leakage current ($V_{DS} = 0$)	$V_{GS} = \pm 20\text{V}$	-	-	± 200	nA
$V_{GS(th)}$	Gate threshold voltage	$V_{DS} = V_{GS}$, $I_D = 250\ \mu\text{A}$	2	-	4	V
$R_{DS(on)}$	Static drain-source on resistance	$V_{GS} = 10\text{ V}$, $I_D = 11\text{ A}$	-	0.0055	0.006	Ω

Table 5. Dynamic

Symbol	Parameter	Test conditions	Min.	Typ.	Max.	Unit
C_{iss}	Input capacitance	$V_{DS} = 25\text{ V}$, $f = 1\text{ MHz}$, $V_{GS} = 0$	-	2500	-	pF
C_{oss}	Output capacitance			536		pF
C_{rss}	Reverse transfer capacitance			44		pF
Q_g	Total gate charge	$V_{DD} = 48\text{ V}$, $I_D = 22\text{ A}$	-	41	-	nC
Q_{gs}	Gate-source charge	$V_{GS} = 10\text{ V}$		12		nC
Q_{gd}	Gate-drain charge	Figure 14		10		nC
R_G	Gate input resistance	$f = 1\text{ MHz}$ Gate DC Bias = 0 Test signal level = 20 mV open drain	-	0.9	-	Ω

Table 6. Switching times

Symbol	Parameter	Test conditions	Min.	Typ.	Max.	Unit
$t_{d(on)}$	Turn-on delay time	$V_{DD} = 30\text{ V}$, $I_D = 11\text{ A}$, $R_G = 4.7\ \Omega$, $V_{GS} = 10\text{ V}$ Figure 13	-	16	-	ns
t_r	Rise time			14		ns
$t_{d(off)}$	Turn-off delay time	$V_{DD} = 30\text{ V}$, $I_D = 11\text{ A}$, $R_G = 4.7\ \Omega$, $V_{GS} = 10\text{ V}$ Figure 13	-	28	-	ns
t_f	Fall time			5		ns

Table 7. Source drain diode

Symbol	Parameter	Test conditions	Min.	Typ.	Max.	Unit
I_{SD}	Source-drain current		-	-	22	A
$I_{SDM}^{(1)}$	Source-drain current (pulsed)		-	-	88	A
$V_{SD}^{(2)}$	Forward on voltage	$I_{SD}=22\text{ A}$, $V_{GS}=0$	-	-	1.2	V
t_{rr}	Reverse recovery time	$I_{SD}=22\text{ A}$, $di/dt = 100\text{ A}/\mu\text{s}$, $V_{DD}=30\text{ V}$, $T_j=150^\circ\text{C}$ <i>Figure 18</i>	-	49	-	ns
Q_{rr}	Reverse recovery charge		-	91	-	nC
I_{RRM}	Reverse recovery current		-	3.7	-	A

1. Pulse width limited by package
2. Pulsed: pulse duration = 300 μs , duty cycle 1.5%

2.1 Electrical characteristics (curves)

Figure 2. Safe operating area

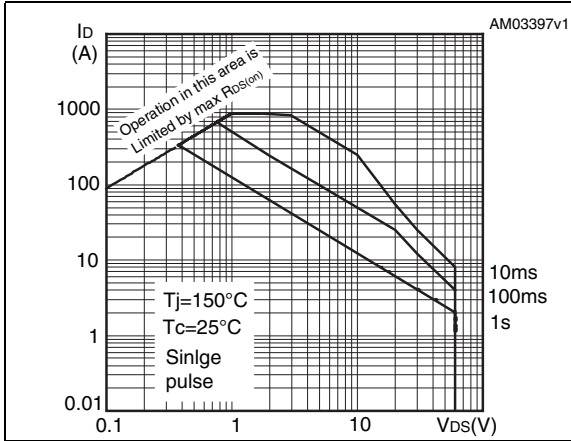

Figure 3. Thermal impedance

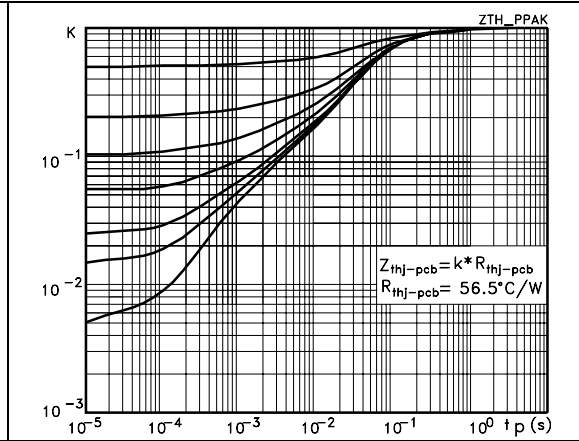

Figure 4. Output characteristics

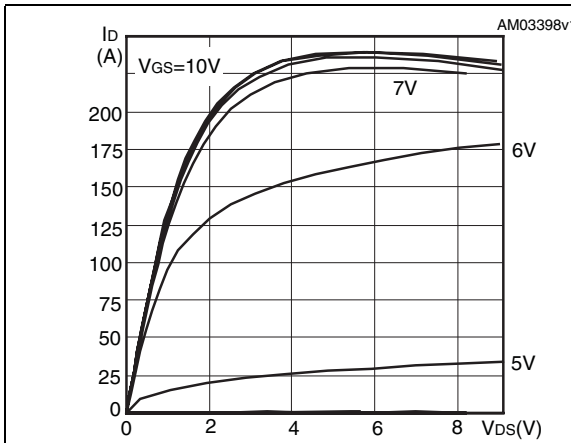

Figure 5. Transfer characteristics

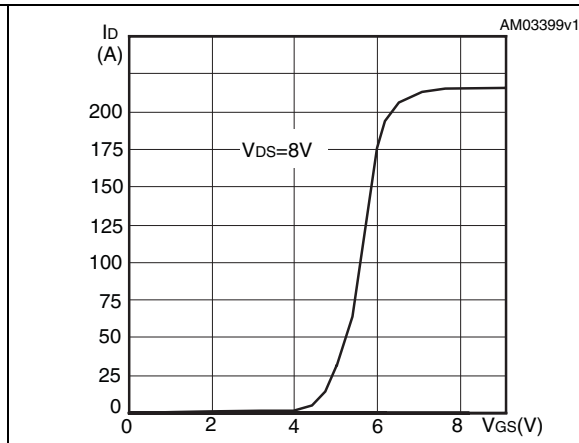

Figure 6. Normalized BV_{DSS} vs temperature

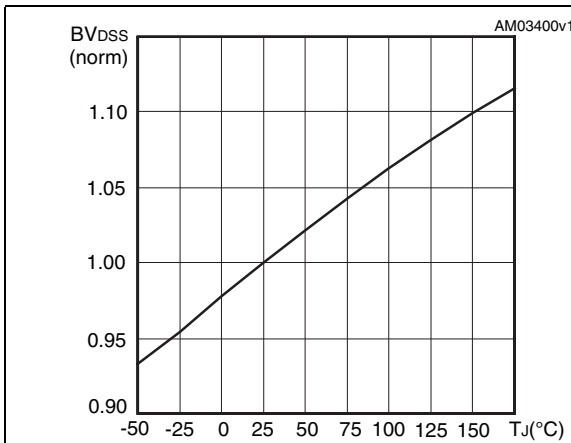

Figure 7. Static drain-source on resistance

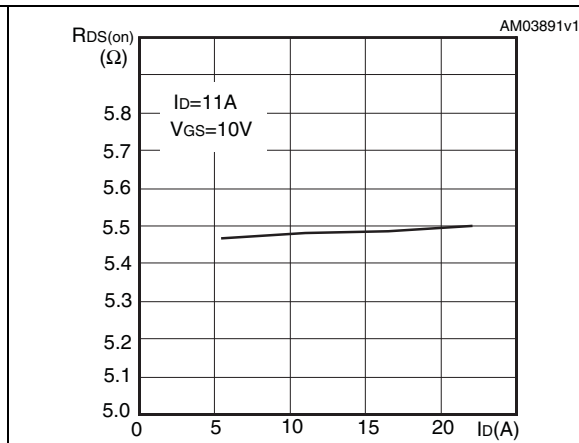

Figure 8. Gate charge vs gate-source voltage Figure 9. Capacitance variations

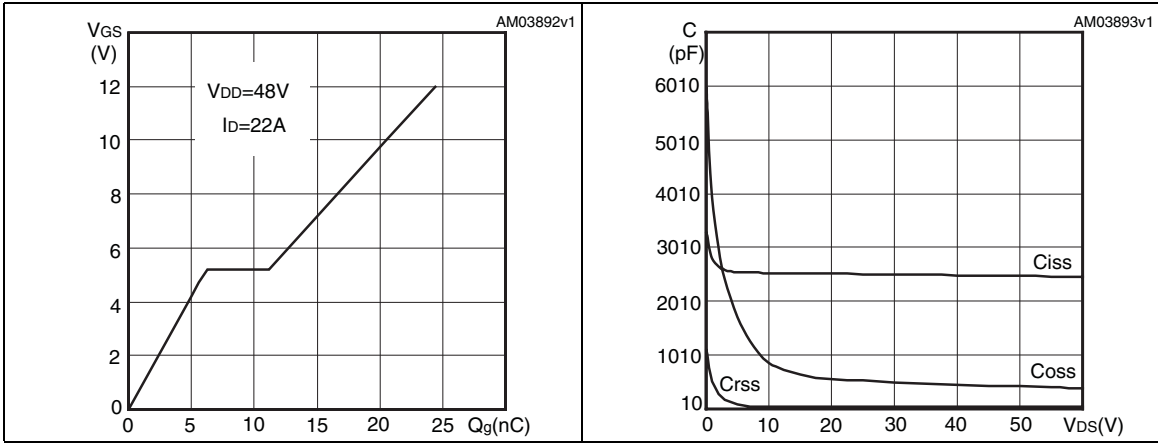

Figure 10. Normalized gate threshold voltage vs temperature Figure 11. Normalized on resistance vs temperature

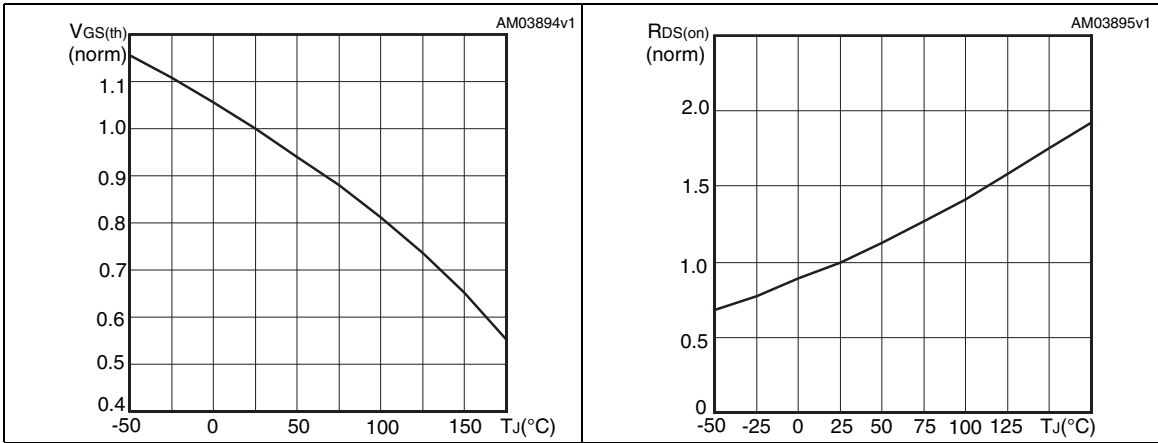
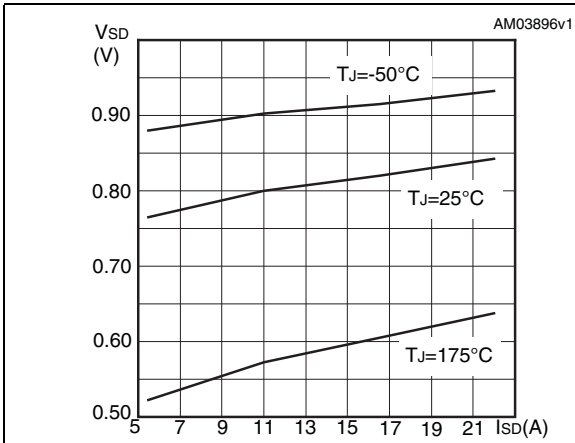

Figure 12. Source-drain diode forward characteristics



3 Test circuits

Figure 13. Switching times test circuit for resistive load

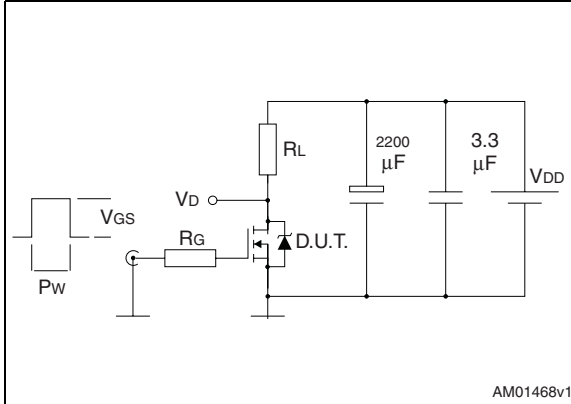

Figure 14. Gate charge test circuit

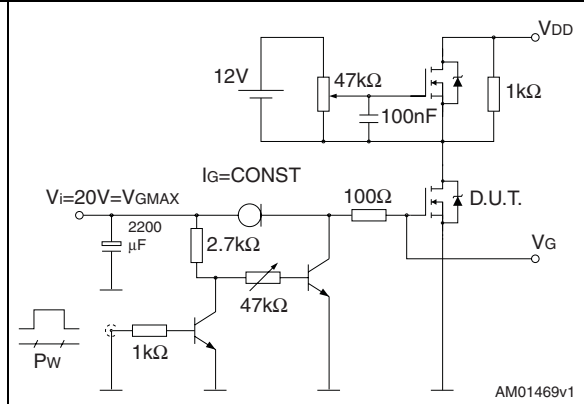

Figure 15. Test circuit for inductive load switching and diode recovery times

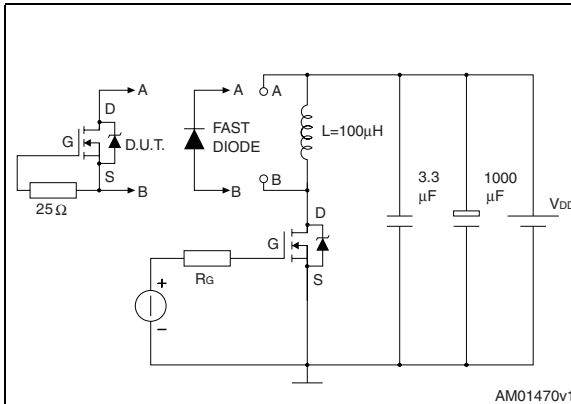

Figure 16. Unclamped inductive load test circuit

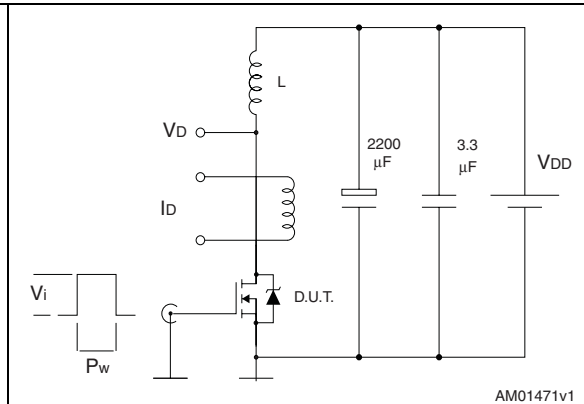

Figure 17. Unclamped inductive waveform

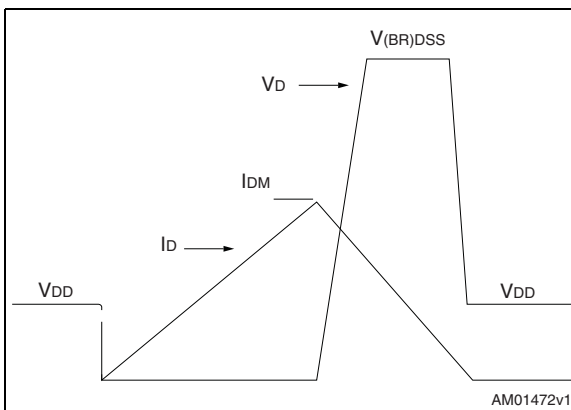

Figure 18. Switching time waveform

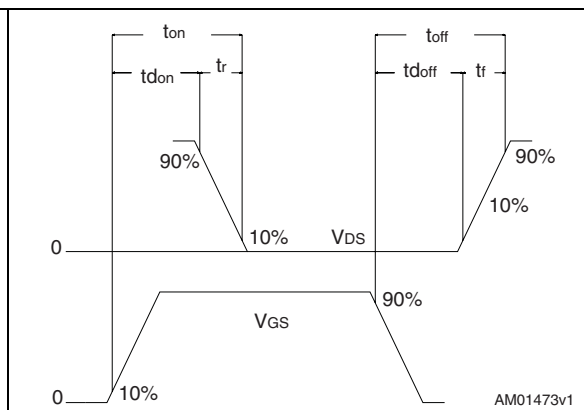
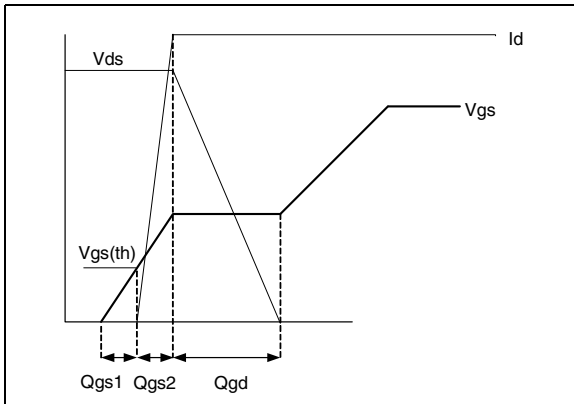

Figure 19. Gate charge waveform



4 Package mechanical data

In order to meet environmental requirements, ST offers these devices in different grades of ECOPACK[®] packages, depending on their level of environmental compliance. ECOPACK[®] specifications, grade definitions and product status are available at: www.st.com. ECOPACK is an ST trademark.

Table 8. PolarPAK® (option "L") mechanical data

Ref.	mm			inch		
	Min.	Typ.	Max.	Min.	Typ.	Max.
A	0.75	0.80	0.85	0.030	0.031	0.033
A1			0.05			0.002
b1	0.48	0.58	0.68	0.019	0.023	0.027
b2	0.41	0.51	0.61	0.016	0.020	0.024
b3	2.19	2.29	2.39	0.086	0.090	0.094
b4	0.89	1.04	1.19	0.035	0.041	0.047
b5	0.23	0.33	0.43	0.009	0.013	0.017
c	0.20	0.25	0.30	0.008	0.010	0.012
D	6	6.15	6.30	0.236	0.242	0.248
D1	5.74	5.89	6.04	0.226	0.232	0.238
E	5.01	5.16	5.31	0.197	0.203	0.209
E1	4.75	4.90	5.05	0.187	0.193	0.199
H1	0.23			0.009		
H2	0.45		0.56	0.018		0.022
H3	0.31	0.41	0.51	0.012	0.016	0.020
H4	0.45		0.56	0.018		0.022
K1	4.22	4.37	4.52	0.166	0.172	0.178
K2	1.08	1.13	1.18	0.043	0.044	0.046
K3	1.37			0.054		
K4	0.24			0.009		
M1	4.30	4.50	4.70	0.169	0.177	0.185
M2	3.43	3.58	3.73	0.135	0.141	0.147
M3	0.22			0.009		
M4	0.05			0.002		
P1	0.15	0.20	0.25	0.006	0.008	0.010
T1	3.48	3.64	4.10	0.137	0.143	0.161
T2	0.56	0.76	0.95	0.022	0.030	0.037
T3	1.20			0.047		
T4	3.90			0.154		
T5		0.18	0.36		0.007	0.014
<	0°	10°	12°	0°	10°	12°

Figure 20. PolarPAK® (option “L”) drawings

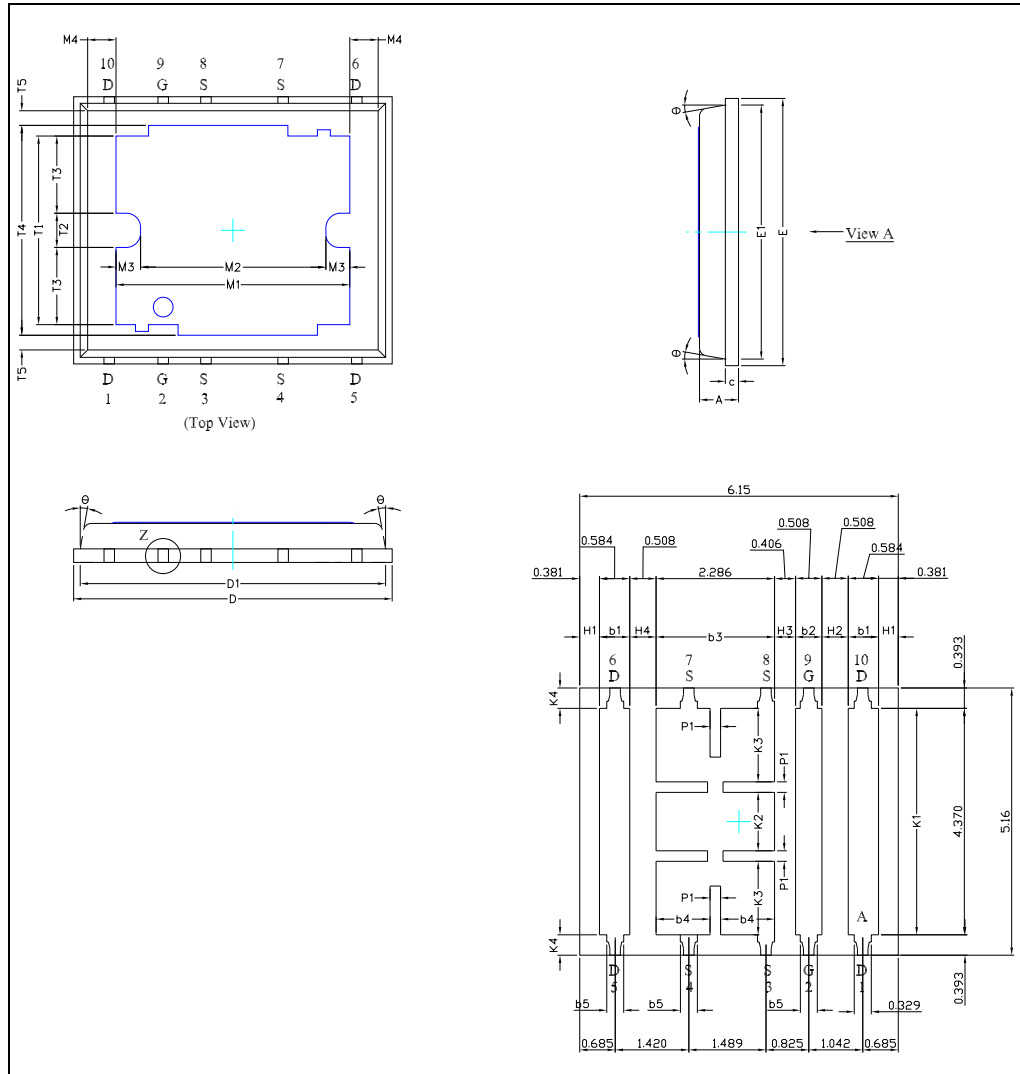
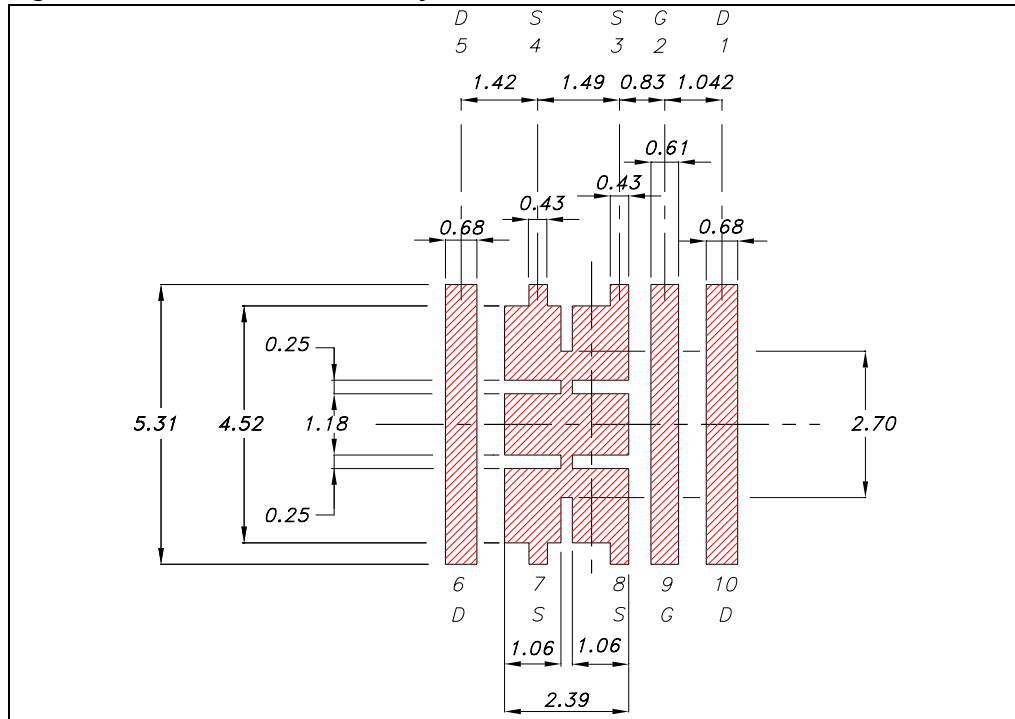

Figure 21. Recommended PAD layout



5 Revision history

Table 9. Document revision history

Date	Revision	Changes
01-Jul-2008	1	First release
16-Apr-2009	2	Document status promoted from preliminary data to datasheet

Please Read Carefully:

Information in this document is provided solely in connection with ST products. STMicroelectronics NV and its subsidiaries ("ST") reserve the right to make changes, corrections, modifications or improvements, to this document, and the products and services described herein at any time, without notice.

All ST products are sold pursuant to ST's terms and conditions of sale.

Purchasers are solely responsible for the choice, selection and use of the ST products and services described herein, and ST assumes no liability whatsoever relating to the choice, selection or use of the ST products and services described herein.

No license, express or implied, by estoppel or otherwise, to any intellectual property rights is granted under this document. If any part of this document refers to any third party products or services it shall not be deemed a license grant by ST for the use of such third party products or services, or any intellectual property contained therein or considered as a warranty covering the use in any manner whatsoever of such third party products or services or any intellectual property contained therein.

UNLESS OTHERWISE SET FORTH IN ST'S TERMS AND CONDITIONS OF SALE ST DISCLAIMS ANY EXPRESS OR IMPLIED WARRANTY WITH RESPECT TO THE USE AND/OR SALE OF ST PRODUCTS INCLUDING WITHOUT LIMITATION IMPLIED WARRANTIES OF MERCHANTABILITY, FITNESS FOR A PARTICULAR PURPOSE (AND THEIR EQUIVALENTS UNDER THE LAWS OF ANY JURISDICTION), OR INFRINGEMENT OF ANY PATENT, COPYRIGHT OR OTHER INTELLECTUAL PROPERTY RIGHT.

UNLESS EXPRESSLY APPROVED IN WRITING BY AN AUTHORIZED ST REPRESENTATIVE, ST PRODUCTS ARE NOT RECOMMENDED, AUTHORIZED OR WARRANTED FOR USE IN MILITARY, AIR CRAFT, SPACE, LIFE SAVING, OR LIFE SUSTAINING APPLICATIONS, NOR IN PRODUCTS OR SYSTEMS WHERE FAILURE OR MALFUNCTION MAY RESULT IN PERSONAL INJURY, DEATH, OR SEVERE PROPERTY OR ENVIRONMENTAL DAMAGE. ST PRODUCTS WHICH ARE NOT SPECIFIED AS "AUTOMOTIVE GRADE" MAY ONLY BE USED IN AUTOMOTIVE APPLICATIONS AT USER'S OWN RISK.

Resale of ST products with provisions different from the statements and/or technical features set forth in this document shall immediately void any warranty granted by ST for the ST product or service described herein and shall not create or extend in any manner whatsoever, any liability of ST.

ST and the ST logo are trademarks or registered trademarks of ST in various countries.

Information in this document supersedes and replaces all information previously supplied.

The ST logo is a registered trademark of STMicroelectronics. All other names are the property of their respective owners.

© 2009 STMicroelectronics - All rights reserved

STMicroelectronics group of companies

Australia - Belgium - Brazil - Canada - China - Czech Republic - Finland - France - Germany - Hong Kong - India - Israel - Italy - Japan - Malaysia - Malta - Morocco - Philippines - Singapore - Spain - Sweden - Switzerland - United Kingdom - United States of America

www.st.com

