



# STD12N65M5, STF12N65M5, STI12N65M5 STP12N65M5, STU12N65M5

N-channel 650 V, 0.39  $\Omega$ , 8.5 A MDmesh™ V Power MOSFET  
DPAK, I<sup>2</sup>PAK, TO-220FP, TO-220, IPAK

## Features

| Type       | V <sub>DSS</sub> @<br>T <sub>Jmax</sub> | R <sub>DS(on)</sub><br>max | I <sub>D</sub>       | P <sub>TOT</sub> |
|------------|---|----------------------------|----------------------|------------------|
| STD12N65M5 | 710 V                                   | < 0.43 $\Omega$            | 8.5 A                | 70 W             |
| STF12N65M5 |   |                            | 8.5 A <sup>(1)</sup> | 25 W             |
| STI12N65M5 |   |                            | 8.5 A                | 70 W             |
| STP12N65M5 |   |                            | 8.5 A                | 70 W             |
| STU12N65M5 |   |                            | 8.5 A                | 70 W             |

1. Limited only by maximum temperature allowed

- Worldwide best R<sub>DS(on)</sub> \* area
- Higher V<sub>DSS</sub> rating and high dv/dt capability
- Excellent switching performance
- Easy to drive
- 100% avalanche tested

## Application

Switching applications

## Description

The devices are N-channel MDmesh™ V Power MOSFET based on an innovative proprietary vertical process technology, which is combined with STMicroelectronics' well-known PowerMESH™ horizontal layout structure. The resulting product has extremely low on-resistance, which is unmatched among silicon-based Power MOSFETs, making it especially suitable for applications which require superior power density and outstanding efficiency.

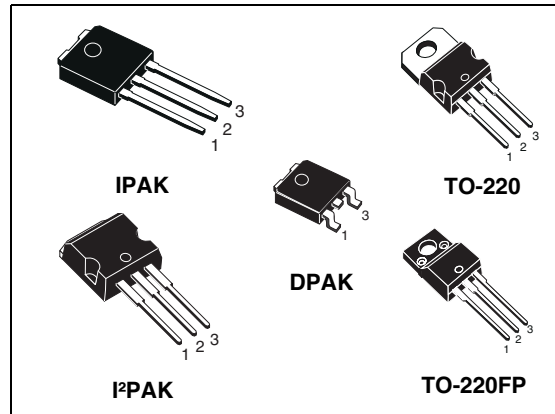
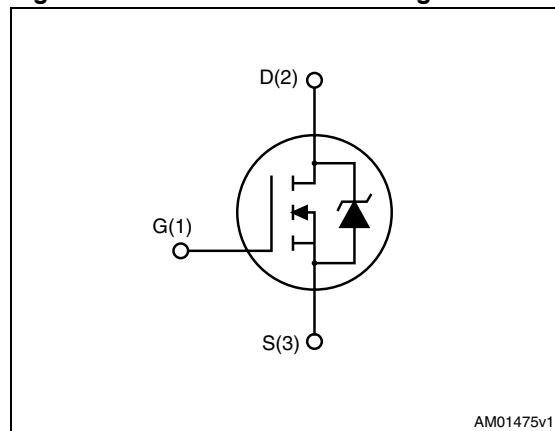

Figure 1. Internal schematic diagram



AM01475v1

Table 1. Device summary

| Order codes | Marking | Packages           | Packaging     |
|-------------|---------|--------------------|---------------|
| STD12N65M5  | 12N65M5 | DPAK               | Tape and reel |
| STF12N65M5  |         | TO-220FP           | Tube          |
| STI12N65M5  |         | I <sup>2</sup> PAK | Tube          |
| STP12N65M5  |         | TO-220             | Tube          |
| STU12N65M5  |         | IPAK               | Tube          |

## Contents

|          |   |           |
|----------|---|-----------|
| <b>1</b> | <b>Electrical ratings</b> .....               | <b>3</b>  |
| <b>2</b> | <b>Electrical characteristics</b> .....       | <b>4</b>  |
|          | 2.1 Electrical characteristics (curves) ..... | 6         |
| <b>3</b> | <b>Test circuits</b> .....                    | <b>9</b>  |
| <b>4</b> | <b>Package mechanical data</b> .....          | <b>10</b> |
| <b>5</b> | <b>Packaging mechanical data</b> .....        | <b>16</b> |
| <b>6</b> | <b>Revision history</b> .....                 | <b>17</b> |

# 1 Electrical ratings (a)

**Table 2. Absolute maximum ratings**

| Symbol                         | Parameter  | Value                                  |                    | Unit |
|--------------------------------|--|--|--------------------|------|
|                                |  | TO-220, IPAK, DPAK, I <sup>2</sup> PAK | TO-220FP           |      |
| V <sub>DS</sub>                | Drain-source voltage (V <sub>GS</sub> = 0)   | 650                                    |                    | V    |
| V <sub>GS</sub>                | Gate-source voltage  | 25                                     |                    | V    |
| I <sub>D</sub>                 | Drain current (continuous) at T <sub>C</sub> = 25 °C   | 8.5                                    | 8.5 <sup>(1)</sup> | A    |
| I <sub>D</sub>                 | Drain current (continuous) at T <sub>C</sub> = 100 °C  | 5.4                                    | 5.4 <sup>(1)</sup> | A    |
| I <sub>DM</sub> <sup>(2)</sup> | Drain current (pulsed)   | 34                                     | 34 <sup>(1)</sup>  | A    |
| P <sub>TOT</sub>               | Total dissipation at T <sub>C</sub> = 25 °C  | 70                                     | 25                 | W    |
| I <sub>AR</sub>                | Avalanche current, repetitive or not-repetitive (pulse width limited by T <sub>j</sub> max)                                | 2.5                                    |                    | A    |
| E <sub>AS</sub>                | Single pulse avalanche energy (starting T <sub>j</sub> = 25 °C, I <sub>D</sub> = I <sub>AR</sub> , V <sub>DD</sub> = 50 V) | 150                                    |                    | mJ   |
| dv/dt <sup>(3)</sup>           | Peak diode recovery voltage slope  | 15                                     |                    | V/ns |
| V <sub>ISO</sub>               | Insulation withstand voltage (RMS) from all three leads to external heat sink (t = 1 s; T <sub>C</sub> = 25 °C)            |  | 2500               | V    |
| T <sub>stg</sub>               | Storage temperature  | - 55 to 150                            |                    | °C   |
| T <sub>j</sub>                 | Max. operating junction temperature  | 150                                    |                    | °C   |

- Limited only by maximum temperature allowed
- Pulse width limited by safe operating area
- I<sub>SD</sub> ≤ 8.5 A, di/dt ≤ 400 A/μs; V<sub>Peak</sub> < V<sub>(BR)DSS</sub>

**Table 3. Thermal data**

| Symbol                              | Parameter                                      | Value |      |                    |        |          | Unit |
|-------------------------------------|--|-------|------|--------------------|--------|----------|------|
|                                     |  | DPAK  | IPAK | I <sup>2</sup> PAK | TO-220 | TO-220FP |      |
| R <sub>thj-case</sub>               | Thermal resistance junction-case max           | 1.79  |      |                    | 5      | °C/W     |      |
| R <sub>thj-amb</sub>                | Thermal resistance junction-ambient max        |       | 100  | 62.5               |        | °C/W     |      |
| R <sub>thj-pcb</sub> <sup>(1)</sup> | Thermal resistance junction-pcb max            | 50    |      |                    |        | °C/W     |      |
| T <sub>l</sub>                      | Maximum lead temperature for soldering purpose | 300   |      |                    |        | °C       |      |

- When mounted on 1inch<sup>2</sup> FR-4 board, 2 oz Cu

a. All data which refers solely to the TO-220FP package is preliminary



## 2 Electrical characteristics

( $T_C = 25\text{ °C}$  unless otherwise specified)

**Table 4. On /off states**

| Symbol        | Parameter  | Test conditions  | Min. | Typ. | Max.     | Unit                           |
|---------------|--|--|------|------|----------|--------------------------------|
| $V_{(BR)DSS}$ | Drain-source breakdown voltage                   | $I_D = 1\text{ mA}$ , $V_{GS} = 0$   | 650  |      |          | V                              |
| $I_{DSS}$     | Zero gate voltage drain current ( $V_{GS} = 0$ ) | $V_{DS} = \text{Max rating}$<br>$V_{DS} = \text{Max rating}$ , $T_C = 125\text{ °C}$ |      |      | 1<br>100 | $\mu\text{A}$<br>$\mu\text{A}$ |
| $I_{GSS}$     | Gate-body leakage current ( $V_{DS} = 0$ )       | $V_{GS} = \pm 25\text{ V}$   |      |      | 100      | nA                             |
| $V_{GS(th)}$  | Gate threshold voltage                           | $V_{DS} = V_{GS}$ , $I_D = 250\text{ }\mu\text{A}$                                   | 3    | 4    | 5        | V                              |
| $R_{DS(on)}$  | Static drain-source on resistance                | $V_{GS} = 10\text{ V}$ , $I_D = 4.3\text{ A}$  |      | 0.39 | 0.43     | $\Omega$                       |

**Table 5. Dynamic**

| Symbol            | Parameter                             | Test conditions  | Min. | Typ. | Max. | Unit     |
|-------------------|---------------------------------------|--|------|------|------|----------|
| $C_{iss}$         | Input capacitance                     | $V_{DS} = 100\text{ V}$ , $f = 1\text{ MHz}$ ,<br>$V_{GS} = 0$   | -    | 900  | -    | pF       |
| $C_{oss}$         | Output capacitance                    |  |      | 22   |      | pF       |
| $C_{rss}$         | Reverse transfer capacitance          |  |      | 2    |      | pF       |
| $C_{o(tr)}^{(1)}$ | Equivalent capacitance time related   | $V_{DS} = 0\text{ to }520\text{ V}$ , $V_{GS} = 0$   | -    | 64   | -    | pF       |
| $C_{o(er)}^{(2)}$ | Equivalent capacitance energy related |  |      | 21   |      | pF       |
| $R_G$             | Intrinsic gate resistance             | $f = 1\text{ MHz}$ open drain  | -    | 2.5  | -    | $\Omega$ |
| $Q_g$             | Total gate charge                     | $V_{DD} = 520\text{ V}$ , $I_D = 4.3\text{ A}$ ,<br>$V_{GS} = 10\text{ V}$<br>(see <a href="#">Figure 20</a> ) | -    | 22   | -    | nC       |
| $Q_{gs}$          | Gate-source charge                    |  |      | 9    |      | nC       |
| $Q_{gd}$          | Gate-drain charge                     |  |      | 7    |      | nC       |

1. Time related is defined as a constant equivalent capacitance giving the same charging time as  $C_{oss}$  when  $V_{DS}$  increases from 0 to 80%  $V_{DSS}$
2. Energy related is defined as a constant equivalent capacitance giving the same stored energy as  $C_{oss}$  when  $V_{DS}$  increases from 0 to 80%  $V_{DSS}$

**Table 6. Switching times**

| Symbol      | Parameter          | Test conditions                        | Min. | Typ. | Max. | Unit |
|-------------|--------------------|--|------|------|------|------|
| $t_d$ (V)   | Voltage delay time | $V_{DD} = 400$ V, $I_D = 5$ A,         |      | 28   |      | ns   |
| $t_r$ (V)   | Voltage rise time  | $R_G = 4.7$ $\Omega$ , $V_{GS} = 10$ V | -    | 9.5  | -    | ns   |
| $t_f$ (i)   | Current fall time  | (see <a href="#">Figure 21</a> )       |      | 24   |      | ns   |
| $t_c$ (off) | Crossing time      | (see <a href="#">Figure 24</a> )       |      | 34   |      | ns   |

**Table 7. Source drain diode**

| Symbol          | Parameter                     | Test conditions                                   | Min. | Typ. | Max. | Unit    |
|-----------------|-------------------------------|---|------|------|------|---------|
| $I_{SD}$        | Source-drain current          |   |      |      | 8.5  | A       |
| $I_{SDM}^{(1)}$ | Source-drain current (pulsed) |   |      |      | 34   | A       |
| $V_{SD}^{(2)}$  | Forward on voltage            | $I_{SD} = 8.5$ A, $V_{GS} = 0$                    |      |      | 1.5  | V       |
| $t_{rr}$        | Reverse recovery time         | $I_{SD} = 8.5$ A, $di/dt = 100$ A/ $\mu$ s        |      | 230  |      | ns      |
| $Q_{rr}$        | Reverse recovery charge       | $V_{DD} = 100$ V (see <a href="#">Figure 24</a> ) |      | 2.2  |      | $\mu$ C |
| $I_{RRM}$       | Reverse recovery current      |   |      | 19   |      | A       |
| $t_{rr}$        | Reverse recovery time         | $I_{SD} = 8.5$ A, $di/dt = 100$ A/ $\mu$ s        |      | 280  |      | ns      |
| $Q_{rr}$        | Reverse recovery charge       | $V_{DD} = 100$ V, $T_j = 150$ °C                  |      | 2.7  |      | $\mu$ C |
| $I_{RRM}$       | Reverse recovery current      | (see <a href="#">Figure 24</a> )                  |      | 19   |      | A       |

1. Pulse width limited by safe operating area

2. Pulsed: pulse duration = 300  $\mu$ s, duty cycle 1.5%

## 2.1 Electrical characteristics (curves)

Figure 2. Safe operating area for TO-220 and Figure 3. Thermal impedance for TO-220 and I<sup>2</sup>PAK

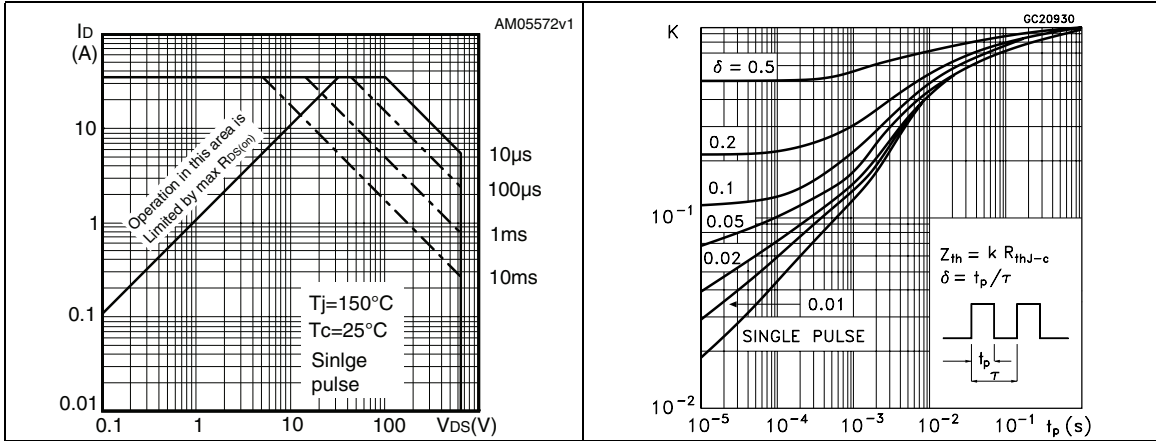

Figure 4. Safe operating area for TO-220FP Figure 5. Thermal impedance for TO-220FP

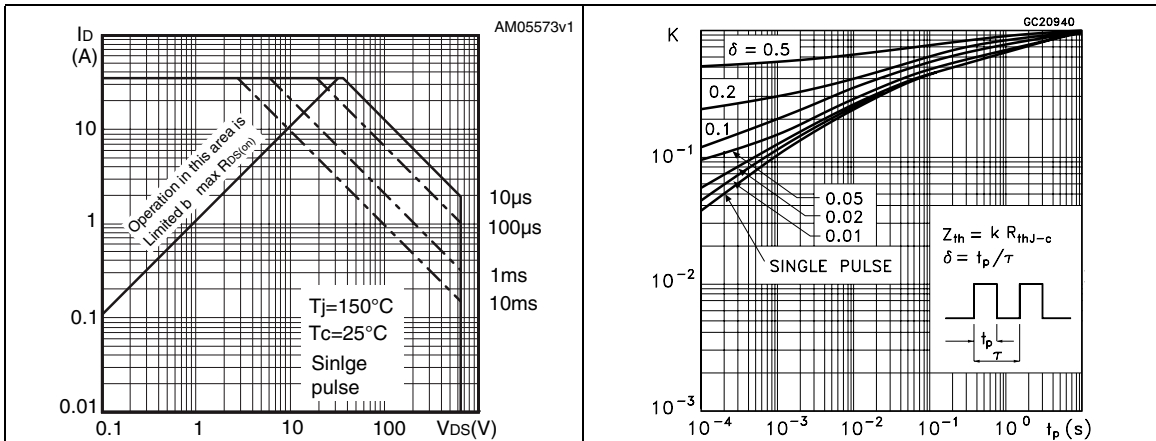

Figure 6. Safe operating area for DPAK, IPAK Figure 7. Thermal impedance for DPAK, IPAK

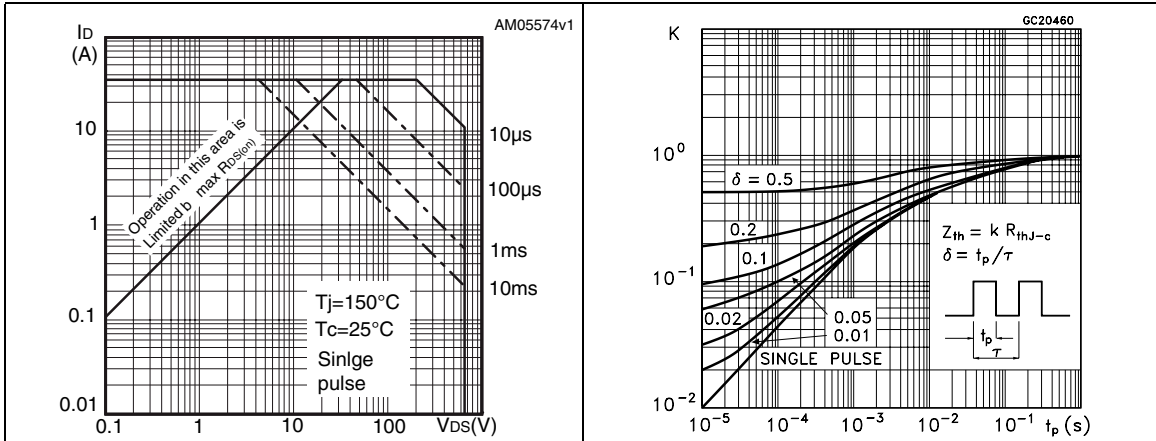

Figure 8. Output characteristics

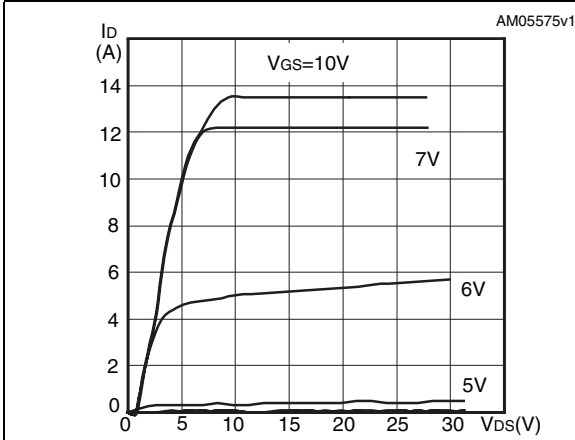

Figure 9. Transfer characteristics

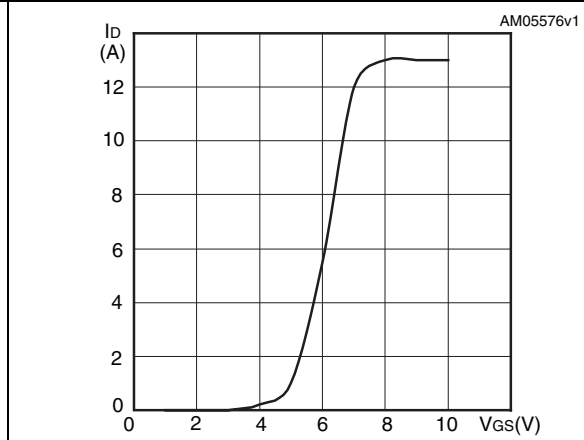

Figure 10. Gate charge vs gate-source voltage Figure 11. Static drain-source on resistance

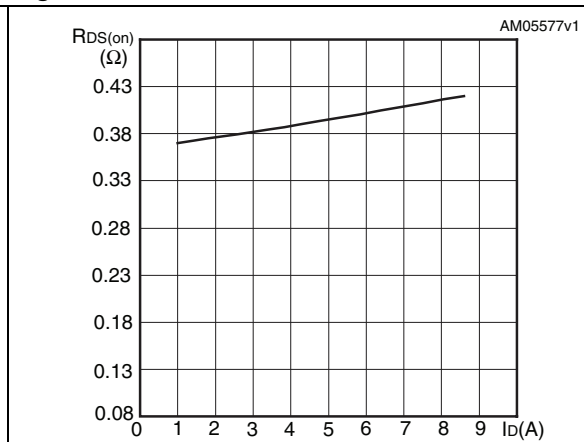
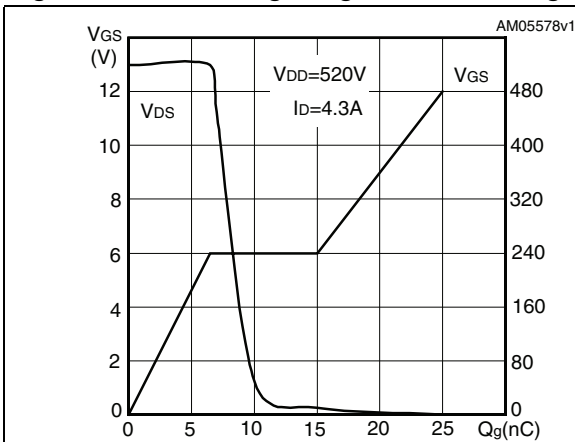

Figure 12. Capacitance variations

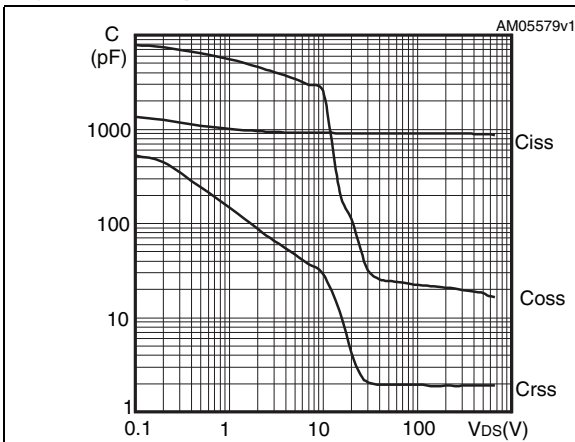

Figure 13. Output capacitance stored energy

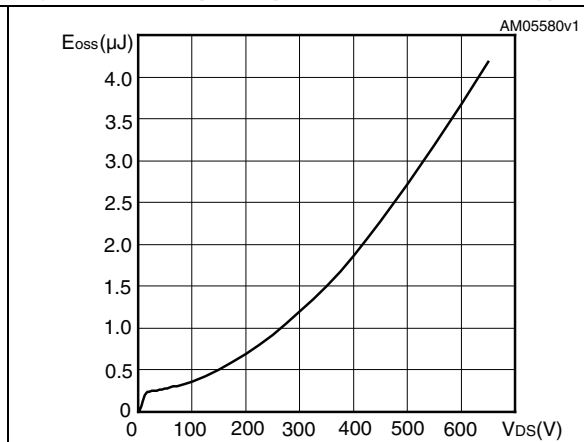

Figure 14. Normalized gate threshold voltage vs temperature

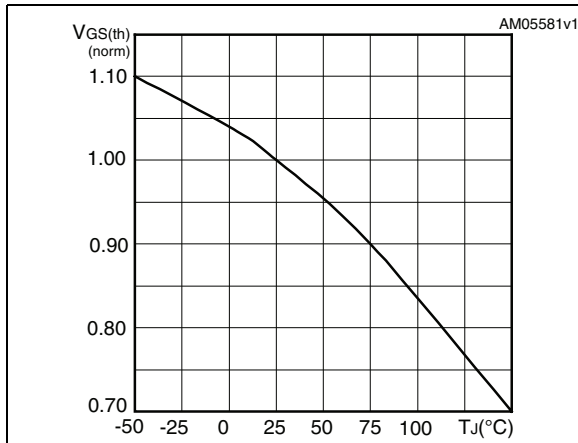

Figure 15. Normalized on resistance vs temperature

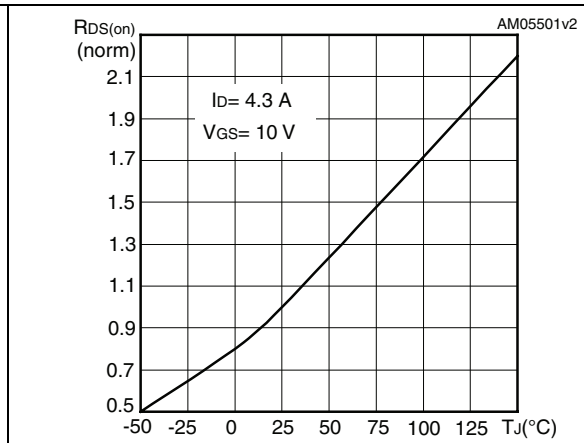

Figure 16. Source-drain diode forward characteristics

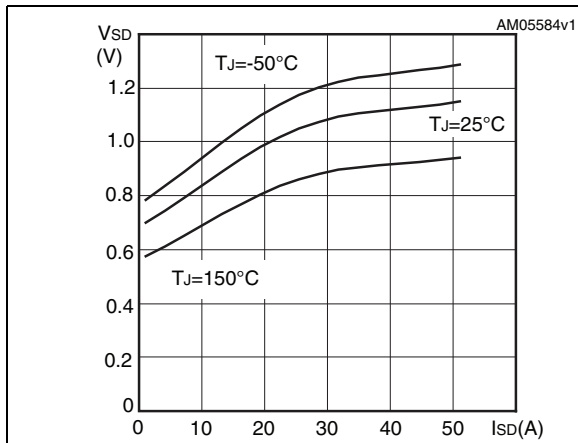

Figure 17. Normalized B<sub>VDSS</sub> vs temperature

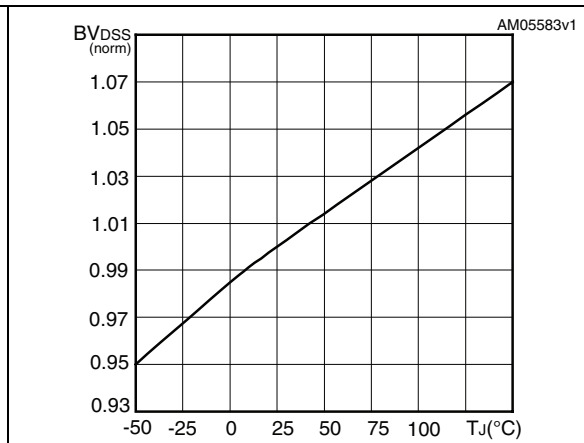
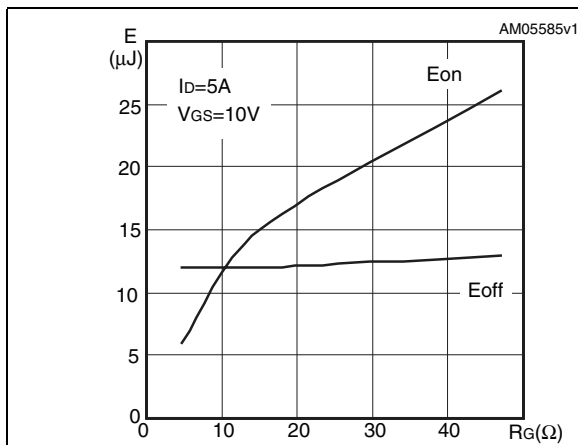

Figure 18. Switching losses vs gate resistance (1)



1. Eon including reverse recovery of a SiC diode



### 3 Test circuits

Figure 19. Switching times test circuit for resistive load

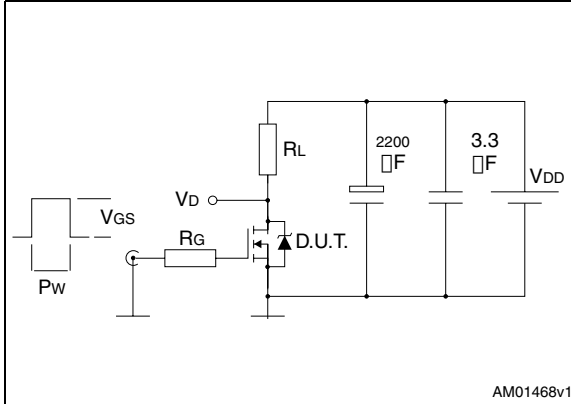

Figure 20. Gate charge test circuit

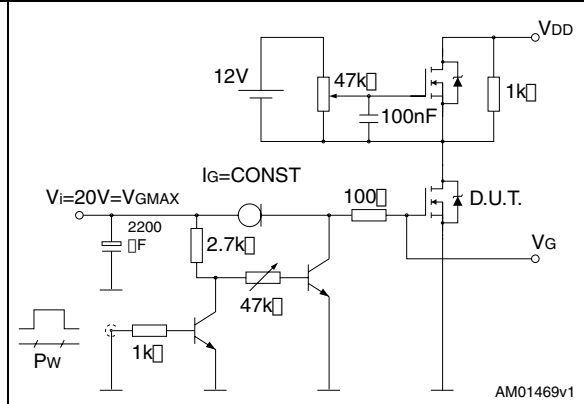

Figure 21. Test circuit for inductive load switching and diode recovery times

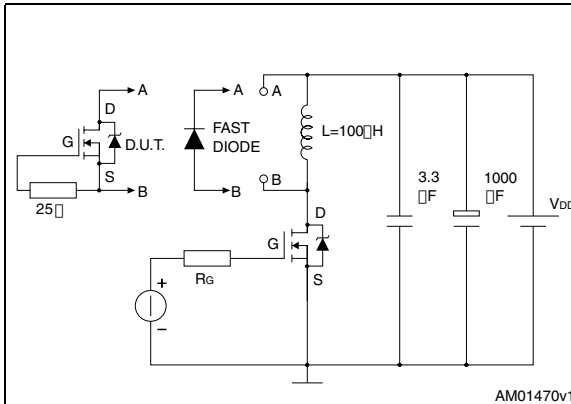

Figure 22. Unclamped inductive load test circuit

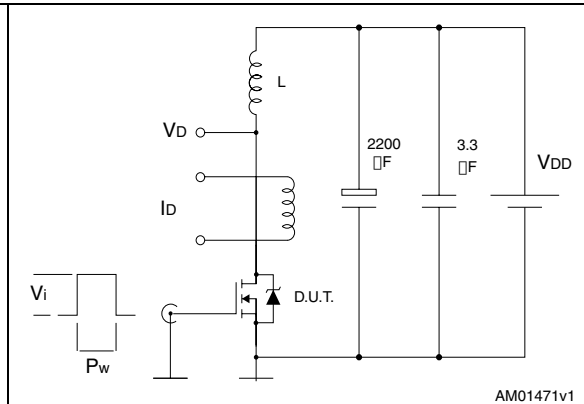

Figure 23. Unclamped inductive waveform

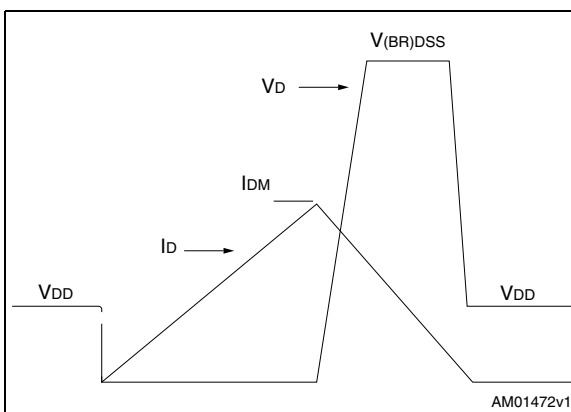
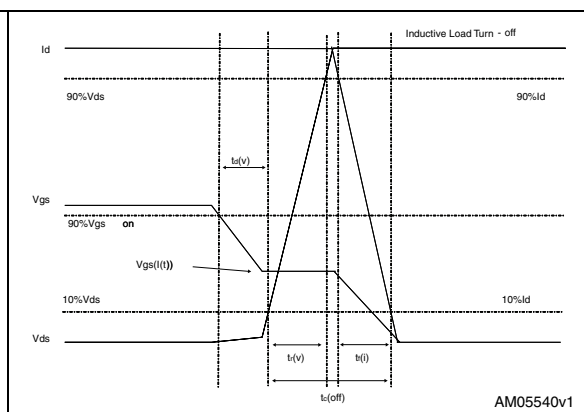

Figure 24. Switching time waveform



## 4 Package mechanical data

In order to meet environmental requirements, ST offers these devices in different grades of ECOPACK<sup>®</sup> packages, depending on their level of environmental compliance. ECOPACK<sup>®</sup> specifications, grade definitions and product status are available at: [www.st.com](http://www.st.com). ECOPACK is an ST trademark.

Table 8. TO-220FP mechanical data

| Dim. | mm   |      |      |
|------|------|------|------|
|      | Min. | Typ. | Max. |
| A    | 4.4  |      | 4.6  |
| B    | 2.5  |      | 2.7  |
| D    | 2.5  |      | 2.75 |
| E    | 0.45 |      | 0.7  |
| F    | 0.75 |      | 1    |
| F1   | 1.15 |      | 1.70 |
| F2   | 1.15 |      | 1.70 |
| G    | 4.95 |      | 5.2  |
| G1   | 2.4  |      | 2.7  |
| H    | 10   |      | 10.4 |
| L2   |      | 16   |      |
| L3   | 28.6 |      | 30.6 |
| L4   | 9.8  |      | 10.6 |
| L5   | 2.9  |      | 3.6  |
| L6   | 15.9 |      | 16.4 |
| L7   | 9    |      | 9.3  |
| Dia  | 3    |      | 3.2  |

Figure 25. TO-220FP drawing

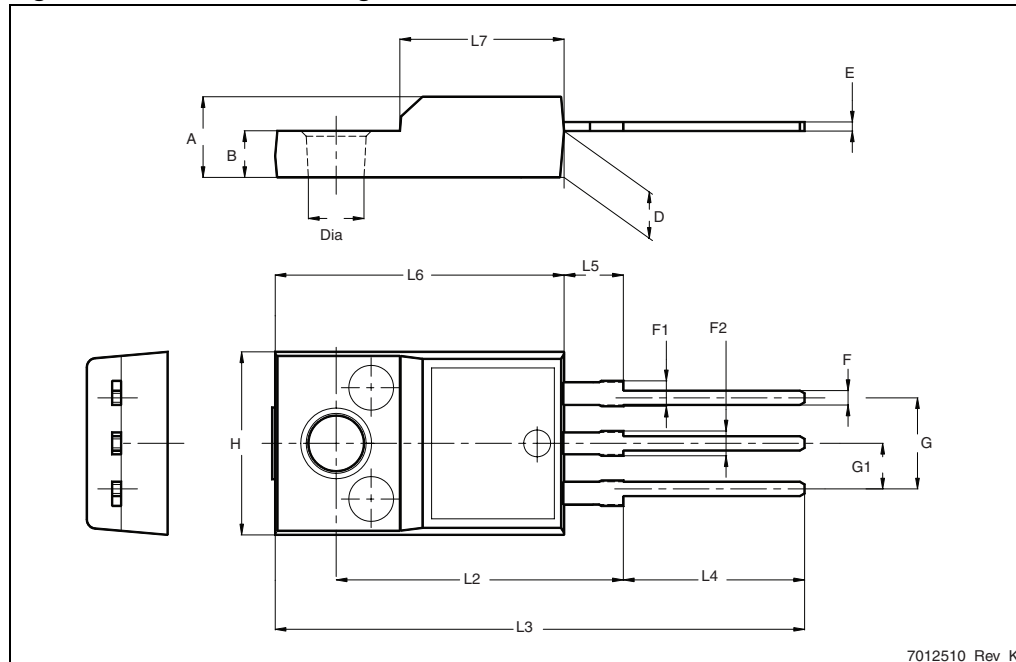

**TO-251 (IPAK) mechanical data**

| DIM. | mm.  |       |      |
|------|------|-------|------|
|      | min. | typ   | max. |
| A    | 2.20 |       | 2.40 |
| A1   | 0.90 |       | 1.10 |
| b    | 0.64 |       | 0.90 |
| b2   |      |       | 0.95 |
| b4   | 5.20 |       | 5.40 |
| c    | 0.45 |       | 0.60 |
| c2   | 0.48 |       | 0.60 |
| D    | 6.00 |       | 6.20 |
| E    | 6.40 |       | 6.60 |
| e    |      | 2.28  |      |
| e1   | 4.40 |       | 4.60 |
| H    |      | 16.10 |      |
| L    | 9.00 |       | 9.40 |
| (L1) | 0.80 |       | 1.20 |
| L2   |      | 0.80  |      |
| V1   |      | 10°   |      |

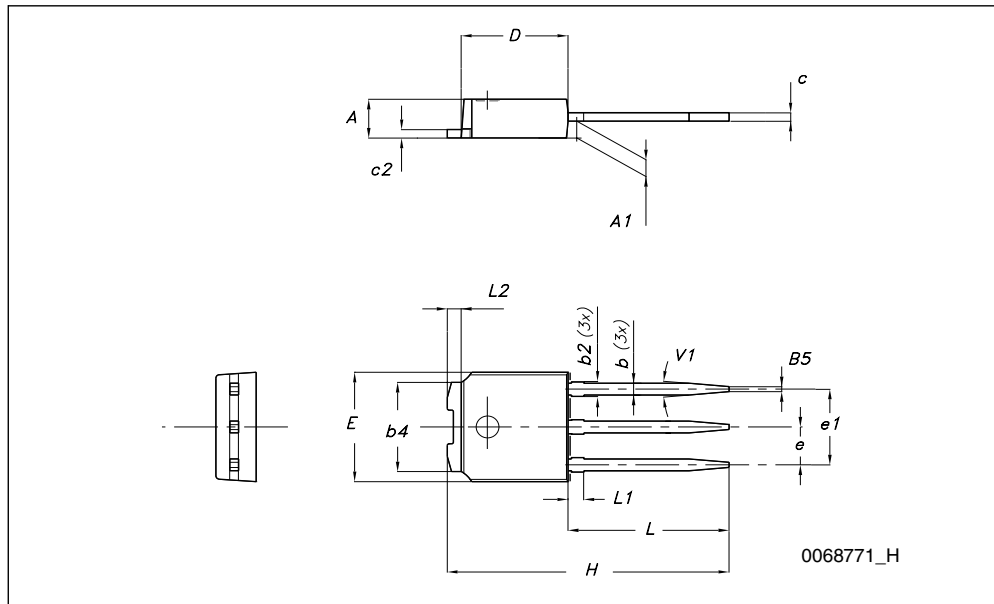

**TO-252 (DPAK) mechanical data**

| DIM. | mm.  |      |       |
|------|------|------|-------|
|      | min. | typ  | max.  |
| A    | 2.20 |      | 2.40  |
| A1   | 0.90 |      | 1.10  |
| A2   | 0.03 |      | 0.23  |
| b    | 0.64 |      | 0.90  |
| b4   | 5.20 |      | 5.40  |
| c    | 0.45 |      | 0.60  |
| c2   | 0.48 |      | 0.60  |
| D    | 6.00 |      | 6.20  |
| D1   |      | 5.10 |       |
| E    | 6.40 |      | 6.60  |
| E1   |      | 4.70 |       |
| e    |      | 2.28 |       |
| e1   | 4.40 |      | 4.60  |
| H    | 9.35 |      | 10.10 |
| L    | 1    |      |       |
| L1   |      | 2.80 |       |
| L2   |      | 0.80 |       |
| L4   | 0.60 |      | 1     |
| R    |      | 0.20 |       |
| V2   | 0°   |      | 8°    |

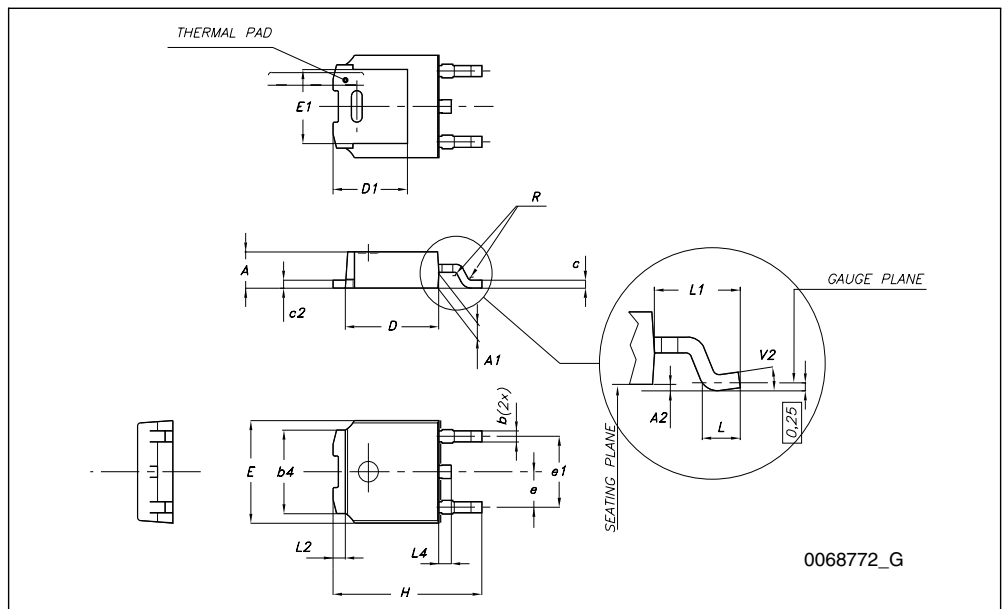

TO-220 type A mechanical data

| Dim | mm    |       |       |
|-----|-------|-------|-------|
|     | Min   | Typ   | Max   |
| A   | 4.40  |       | 4.60  |
| b   | 0.61  |       | 0.88  |
| b1  | 1.14  |       | 1.70  |
| c   | 0.48  |       | 0.70  |
| D   | 15.25 |       | 15.75 |
| D1  |       | 1.27  |       |
| E   | 10    |       | 10.40 |
| e   | 2.40  |       | 2.70  |
| e1  | 4.95  |       | 5.15  |
| F   | 1.23  |       | 1.32  |
| H1  | 6.20  |       | 6.60  |
| J1  | 2.40  |       | 2.72  |
| L   | 13    |       | 14    |
| L1  | 3.50  |       | 3.93  |
| L20 |       | 16.40 |       |
| L30 |       | 28.90 |       |
| ∅P  | 3.75  |       | 3.85  |
| Q   | 2.65  |       | 2.95  |

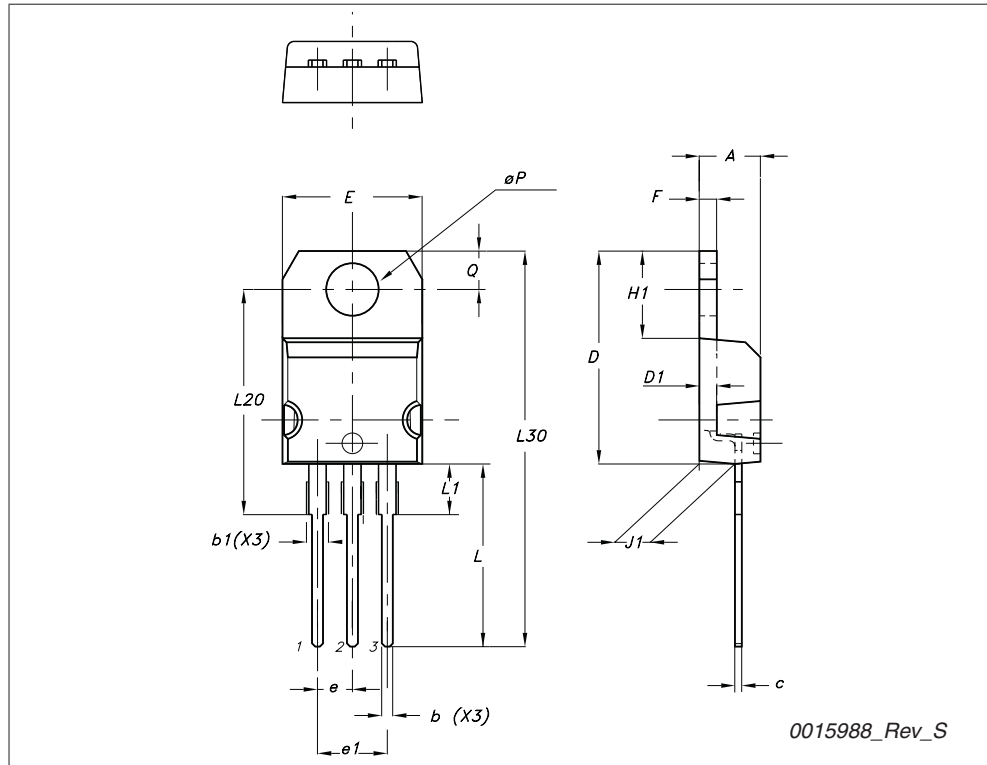

I<sup>2</sup>PAK (TO-262) mechanical data

| Dim | mm   |     |       | inch  |     |       |
|-----|------|-----|-------|-------|-----|-------|
|     | Min  | Typ | Max   | Min   | Typ | Max   |
| A   | 4.40 |     | 4.60  | 0.173 |     | 0.181 |
| A1  | 2.40 |     | 2.72  | 0.094 |     | 0.107 |
| b   | 0.61 |     | 0.88  | 0.024 |     | 0.034 |
| b1  | 1.14 |     | 1.70  | 0.044 |     | 0.066 |
| c   | 0.49 |     | 0.70  | 0.019 |     | 0.027 |
| c2  | 1.23 |     | 1.32  | 0.048 |     | 0.052 |
| D   | 8.95 |     | 9.35  | 0.352 |     | 0.368 |
| e   | 2.40 |     | 2.70  | 0.094 |     | 0.106 |
| e1  | 4.95 |     | 5.15  | 0.194 |     | 0.202 |
| E   | 10   |     | 10.40 | 0.393 |     | 0.410 |
| L   | 13   |     | 14    | 0.511 |     | 0.551 |
| L1  | 3.50 |     | 3.93  | 0.137 |     | 0.154 |
| L2  | 1.27 |     | 1.40  | 0.050 |     | 0.055 |

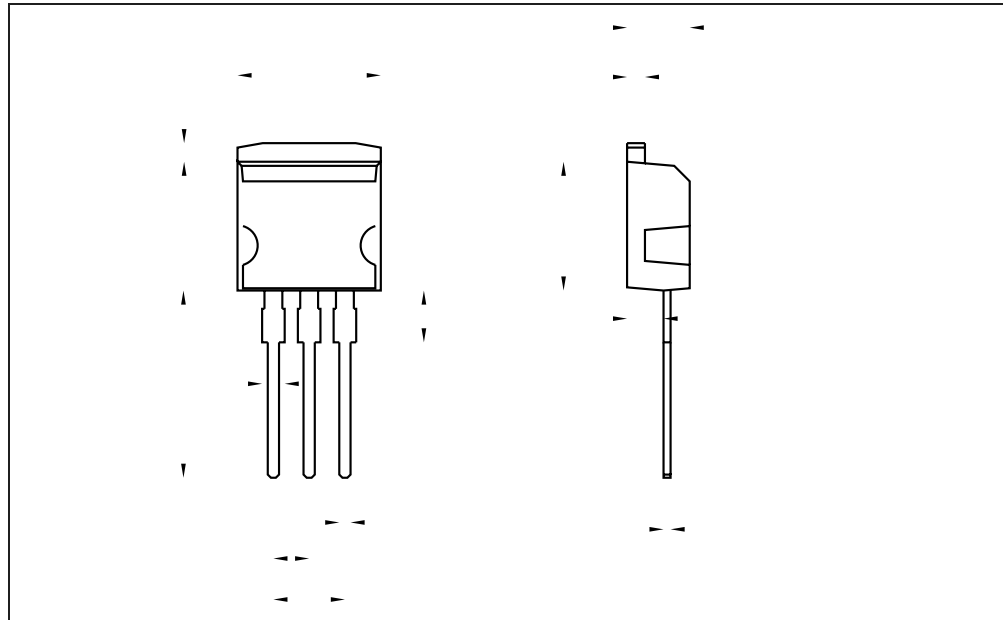

## 5 Packaging mechanical data

### DPAK FOOTPRINT

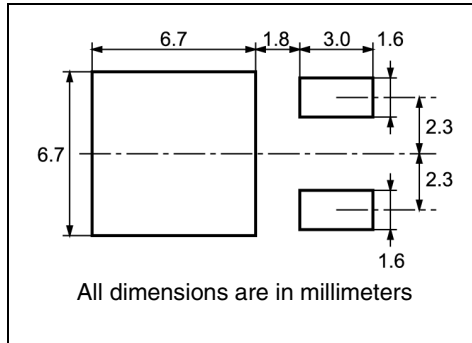

### TAPE AND REEL SHIPMENT

40 mm min. Access hole at slot location

Full radius

Tape slot in core for tape start 2.5mm min. width

G measured at hub

User Direction of Feed

FEED DIRECTION

Bending radius

#### REEL MECHANICAL DATA

| DIM. | mm   |      | inch  |        |
|------|------|------|-------|--------|
|      | MIN. | MAX. | MIN.  | MAX.   |
| A    |      | 330  |       | 12.992 |
| B    | 1.5  |      | 0.059 |        |
| C    | 12.8 | 13.2 | 0.504 | 0.520  |
| D    | 20.2 |      | 0.795 |        |
| G    | 16.4 | 18.4 | 0.645 | 0.724  |
| N    | 50   |      | 1.968 |        |
| T    |      | 22.4 |       | 0.881  |

| BASE QTY | BULK QTY |
|----------|----------|
| 2500     | 2500     |

#### TAPE MECHANICAL DATA

| DIM. | mm   |      | inch  |       |
|------|------|------|-------|-------|
|      | MIN. | MAX. | MIN.  | MAX.  |
| A0   | 6.8  | 7    | 0.267 | 0.275 |
| B0   | 10.4 | 10.6 | 0.409 | 0.417 |
| B1   |      | 12.1 |       | 0.476 |
| D    | 1.5  | 1.6  | 0.059 | 0.063 |
| D1   | 1.5  |      | 0.059 |       |
| E    | 1.65 | 1.85 | 0.065 | 0.073 |
| F    | 7.4  | 7.6  | 0.291 | 0.299 |
| K0   | 2.55 | 2.75 | 0.100 | 0.108 |
| P0   | 3.9  | 4.1  | 0.153 | 0.161 |
| P1   | 7.9  | 8.1  | 0.311 | 0.319 |
| P2   | 1.9  | 2.1  | 0.075 | 0.082 |
| R    | 40   |      | 1.574 |       |
| W    | 15.7 | 16.3 | 0.618 | 0.641 |



## 6 Revision history

Table 9. Document revision history

| Date        | Revision | Changes  |
|-------------|----------|--|
| 24-Feb-2009 | 1        | First release  |
| 27-Feb-2009 | 2        | Corrected package information on first page  |
| 21-Jan-2010 | 3        | Document status promoted from preliminary data to datasheet  |
| 29-Jun-2010 | 4        | <ul style="list-style-type: none"><li>– <a href="#">Figure 15: Normalized on resistance vs temperature</a> has been updated</li><li>– <math>V_{GS}</math> vale in <a href="#">Table 4</a> has been corrected</li></ul> |

**Please Read Carefully:**

Information in this document is provided solely in connection with ST products. STMicroelectronics NV and its subsidiaries ("ST") reserve the right to make changes, corrections, modifications or improvements, to this document, and the products and services described herein at any time, without notice.

All ST products are sold pursuant to ST's terms and conditions of sale.

Purchasers are solely responsible for the choice, selection and use of the ST products and services described herein, and ST assumes no liability whatsoever relating to the choice, selection or use of the ST products and services described herein.

No license, express or implied, by estoppel or otherwise, to any intellectual property rights is granted under this document. If any part of this document refers to any third party products or services it shall not be deemed a license grant by ST for the use of such third party products or services, or any intellectual property contained therein or considered as a warranty covering the use in any manner whatsoever of such third party products or services or any intellectual property contained therein.

**UNLESS OTHERWISE SET FORTH IN ST'S TERMS AND CONDITIONS OF SALE ST DISCLAIMS ANY EXPRESS OR IMPLIED WARRANTY WITH RESPECT TO THE USE AND/OR SALE OF ST PRODUCTS INCLUDING WITHOUT LIMITATION IMPLIED WARRANTIES OF MERCHANTABILITY, FITNESS FOR A PARTICULAR PURPOSE (AND THEIR EQUIVALENTS UNDER THE LAWS OF ANY JURISDICTION), OR INFRINGEMENT OF ANY PATENT, COPYRIGHT OR OTHER INTELLECTUAL PROPERTY RIGHT.**

**UNLESS EXPRESSLY APPROVED IN WRITING BY AN AUTHORIZED ST REPRESENTATIVE, ST PRODUCTS ARE NOT RECOMMENDED, AUTHORIZED OR WARRANTED FOR USE IN MILITARY, AIR CRAFT, SPACE, LIFE SAVING, OR LIFE SUSTAINING APPLICATIONS, NOR IN PRODUCTS OR SYSTEMS WHERE FAILURE OR MALFUNCTION MAY RESULT IN PERSONAL INJURY, DEATH, OR SEVERE PROPERTY OR ENVIRONMENTAL DAMAGE. ST PRODUCTS WHICH ARE NOT SPECIFIED AS "AUTOMOTIVE GRADE" MAY ONLY BE USED IN AUTOMOTIVE APPLICATIONS AT USER'S OWN RISK.**

Resale of ST products with provisions different from the statements and/or technical features set forth in this document shall immediately void any warranty granted by ST for the ST product or service described herein and shall not create or extend in any manner whatsoever, any liability of ST.

ST and the ST logo are trademarks or registered trademarks of ST in various countries.

Information in this document supersedes and replaces all information previously supplied.

The ST logo is a registered trademark of STMicroelectronics. All other names are the property of their respective owners.

© 2010 STMicroelectronics - All rights reserved

STMicroelectronics group of companies

Australia - Belgium - Brazil - Canada - China - Czech Republic - Finland - France - Germany - Hong Kong - India - Israel - Italy - Japan - Malaysia - Malta - Morocco - Philippines - Singapore - Spain - Sweden - Switzerland - United Kingdom - United States of America

[www.st.com](http://www.st.com)