



STB12NM60N/-1 - STF12NM60N STP12NM60N - STW12NM60N

N-channel 600V - 0.35Ω - 10A - D²/I²PAK - TO-220/FP - TO-247
Second generation MDmesh™ Power MOSFET

Features

Type	V _{DSS} (@T _{jmax})	R _{DS(on)}	I _D
STB12NM60N	650V	< 0.41Ω	10A
STB12NM60N-1	650V	< 0.41Ω	10A
STF12NM60N	650V	< 0.41Ω	10A ⁽¹⁾
STP12NM60N	650V	< 0.41Ω	10A
STW12NM60N	650V	< 0.41Ω	10A

1. Limited only by maximum temperature allowed

- 100% avalanche tested
- Low input capacitance and gate charge
- Low gate input resistance

Description

This series of devices implements second generation MDmesh™ technology. This revolutionary Power MOSFET associates a new vertical structure to the Company's strip layout to yield one of the world's lowest on-resistance and gate charge. It is therefore suitable for the most demanding high efficiency converters.

Application

- Switching application

Order codes

Part number	Marking	Package	Packaging
STB12NM60N	B12NM60N	D ² PAK	Tape & reel
STB12NM60N-1	B12NM60N	I ² PAK	Tube
STF12NM60N	F12NM60N	TO-220FP	Tube
STP12NM60N	P12NM60N	TO-220	Tube
STW12NM60N	W12NM60N	TO-247	Tube

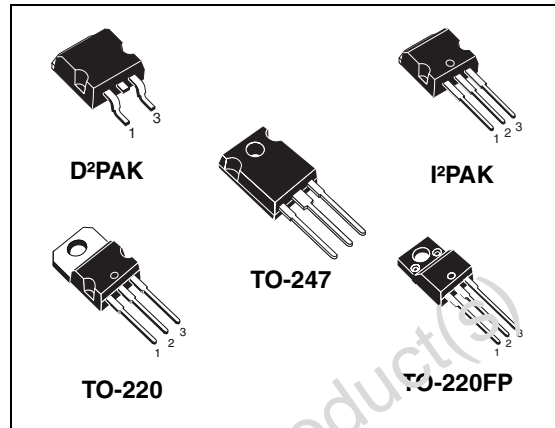

Internal schematic diagram

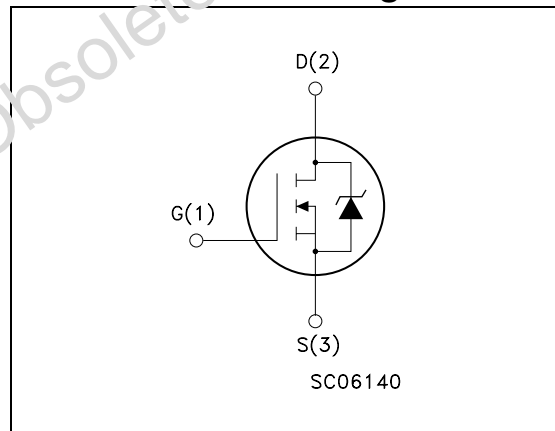

Contents

1	Electrical ratings	3
2	Electrical characteristics	4
	2.1 Electrical characteristics (curves)	6
3	Test circuit	9
4	Package mechanical data	10
5	Packaging mechanical data	16
6	Revision history	17

1 Electrical ratings

Table 1. Absolute maximum ratings

Symbol	Parameter	Value		Unit
		D ² PAK/I ² PAK TO-220/TO-247	TO-220FP	
V _{DS}	Drain-source voltage (V _{GS} =0)	600		V
V _{GS}	Gate-source voltage	± 25		V
I _D	Drain current (continuous) at T _C = 25°C	10	10 ⁽¹⁾	A
I _D	Drain current (continuous) at T _C = 100°C	6.3	6.3 ⁽¹⁾	A
I _{DM} ⁽²⁾	Drain current (pulsed)	40	40 ⁽¹⁾	A
P _{TOT}	Total dissipation at T _C = 25°C	90	25	W
dv/dt ⁽³⁾	Peak diode recovery voltage slope	15		V/ns
V _{ISO}	Insulation withstand voltage (RMS) from all three leads to external heat sink (t=1s; T _C =25°C)	--	2500	V
T _j T _{stg}	Operating junction temperature Storage temperature	-55 to 150		°C

- Limited only by maximum temperature allowed
- Pulse width limited by safe operating area
- I_{SD} ≤ 10A, di/dt ≤ 400A/μs, V_{DD} = 80% V_{(BR)DSS}

Table 2. Thermal data

Symbol	Parameter	D ² PAK/I ² PAK TO-220/TO-247	TO-220FP	Unit
R _{thj-case}	Thermal resistance junction-case max	1.38	5	°C/W
R _{thj-amb}	Thermal resistance junction-amb max	62.5		°C/W
T _I	Maximum lead temperature for soldering purpose	300		°C

Table 3. Avalanche characteristics

Symbol	Parameter	Max value	Unit
I _{AS}	Avalanche current, repetitive or not-repetitive (pulse width limited by T _j max)	3.5	A
E _{AS}	Single pulse avalanche energy (starting T _j =25°C, I _D =I _{AS} , V _{DD} = 50V)	200	mJ

2 Electrical characteristics

($T_{CASE}=25^{\circ}C$ unless otherwise specified)

Table 4. On/off states

Symbol	Parameter	Test conditions	Min.	Typ.	Max.	Unit
$V_{(BR)DSS}$	Drain-source breakdown voltage	$I_D = 1mA, V_{GS} = 0$	600			V
$dv/dt^{(1)}$	Drain-source voltage slope	$V_{DD} = 400V, I_D = 10A,$ $V_{GS} = 10V$		41		V/ns
I_{DSS}	Zero gate voltage drain current ($V_{GS} = 0$)	$V_{DS} = \text{Max rating},$ $V_{DS} = \text{Max rating}, @ 125^{\circ}C$			1 10	μA μA
I_{GSS}	Gate body leakage current ($V_{DS} = 0$)	$V_{GS} = \pm 20V$			100	nA
$V_{GS(th)}$	Gate threshold voltage	$V_{DS} = V_{GS}, I_D = 250\mu A$	2	3	4	V
$R_{DS(on)}$	Static drain-source on resistance	$V_{GS} = 10V, I_D = 5A$		0.35	0.41	Ω

1. Characteristics value at turn off on inductive load

Table 5. Dynamic

Symbol	Parameter	Test conditions	Min.	Typ.	Max.	Unit
$g_{fs}^{(1)}$	Forward transconductance	$V_{DS} = 15V, I_D = 5A$		8		S
C_{iss}	Input capacitance	$V_{DS} = 50V, f = 1MHz,$ $V_{GS} = 0$		960		pF
C_{oss}	Output capacitance			65		pF
C_{rss}	Reverse transfer capacitance			7		pF
$C_{oss\ eq.}^{(2)}$	Equivalent output capacitance	$V_{GS} = 0, V_{DS} = 0V \text{ to } 480V$		180		pF
R_g	Gate input resistance	$f = 1MHz$ Gate DC Bias=0 Test signal level=20mV open drain		5		Ω
Q_g	Total gate charge	$V_{DD} = 480V, I_D = 10A$		30.5		nC
Q_{gs}	Gate-source charge	$V_{GS} = 10V$		5		nC
Q_{gd}	Gate-drain charge	(see Figure 18)		16		nC

1. Pulsed: pulse duration = 300 μs , duty cycle 1.5%

2. $C_{oss\ eq.}$ is defined as a constant equivalent capacitance giving the same charging time as C_{oss} when V_{DS} increases from 0 to 80% V_{DSS}

Table 6. Switching times

Symbol	Parameter	Test conditions	Min	Typ	Max	Unit
$t_{d(on)}$	Turn-on delay time	$V_{DD} = 300V, I_D = 5A,$ $R_G = 4.7\Omega, V_{GS} = 10V$ (see Figure 17)		15		ns
t_r	Rise time			9		ns
$t_{d(off)}$	Turn-off delay time			60		ns
t_f	Fall time			10		ns

Table 7. Source drain diode

Symbol	Parameter	Test conditions	Min	Typ	Max	Unit
I_{SD}	Source-drain current				10	A
$I_{SDM}^{(1)}$	Source-drain current (pulsed)				40	A
$V_{SD}^{(2)}$	Forward on voltage	$I_{SD} = 10A, V_{GS}=0$			1.3	V
t_{rr}	Reverse recovery time	$I_{SD} = 10A, di/dt = 100A/\mu s,$ $V_{DD} = 100V, T_j = 25^\circ C$ (see Figure 19)		360		ns
Q_{rr}	Reverse recovery charge			3.5		μC
I_{RRM}	Reverse recovery current			20		A
t_{rr}	Reverse recovery time	$V_{DD} = 100V$ $di/dt = 100A/\mu s, I_{SD} = 10A$ $T_j = 150^\circ C$ (see Figure 19)		530		ns
Q_{rr}	Reverse recovery charge			5.20		μC
I_{RRM}	Reverse recovery current			20		A

1. Pulse width limited by safe operating area

2. Pulsed: pulse duration = 300 μs , duty cycle 1.5%

2.1 Electrical characteristics (curves)

Figure 1. Safe operating area for TO-220 / D²PAK / I²PAK

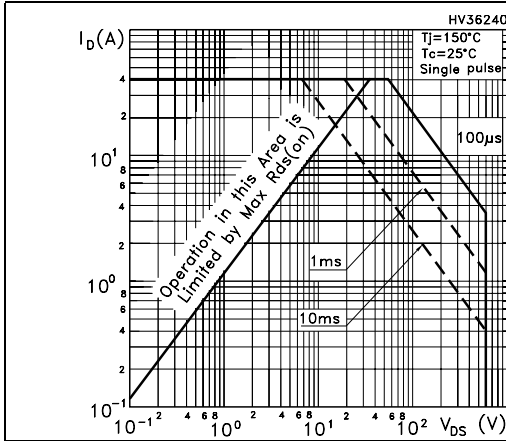

Figure 2. Thermal impedance for TO-220 / D²PAK / I²PAK

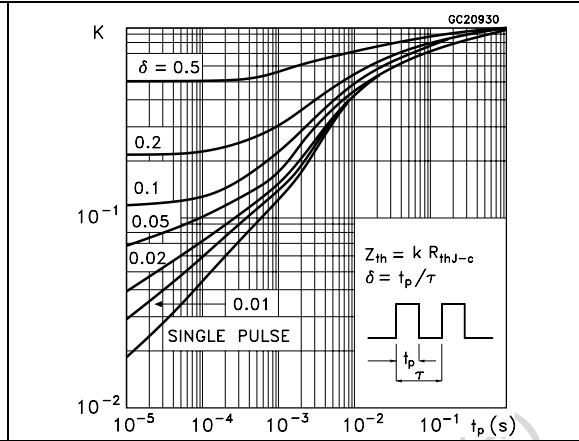

Figure 3. Safe operating area for TO-220FP

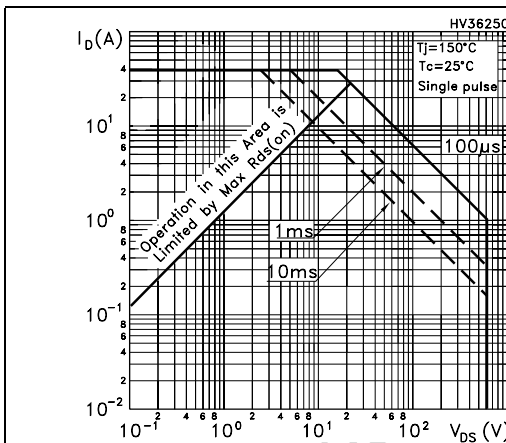

Figure 4. Thermal impedance for TO-220FP

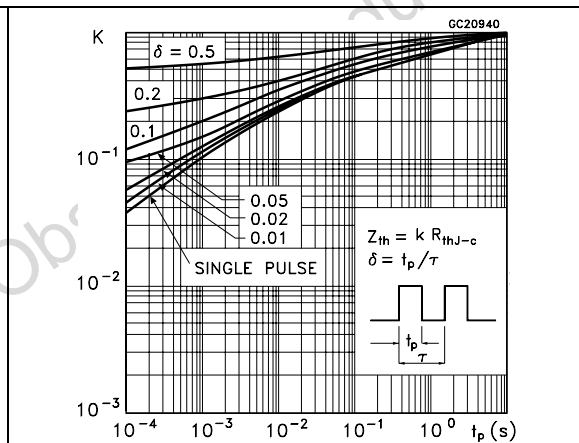

Figure 5. Safe operating area for TO-247

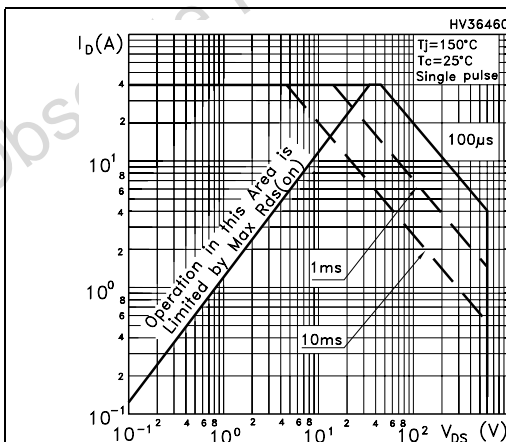

Figure 6. Thermal impedance for TO-247

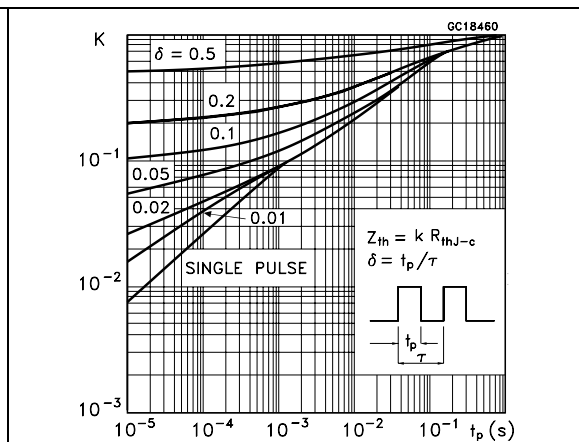

Figure 7. Output characteristics

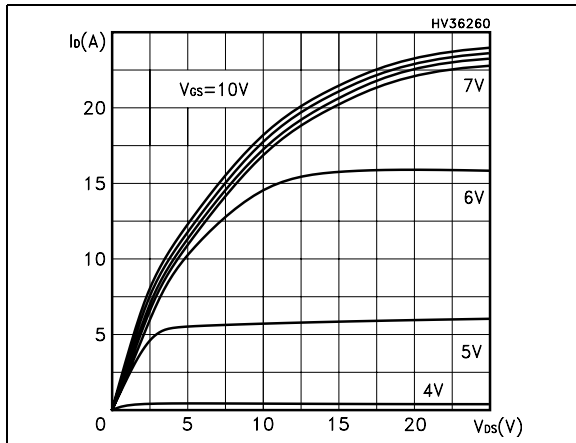

Figure 8. Transfer characteristics

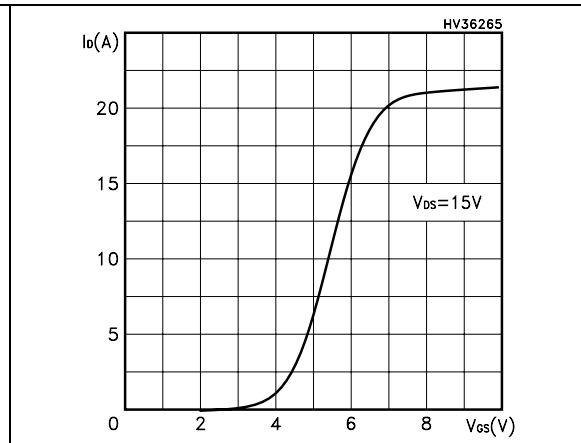

Figure 9. Transconductance

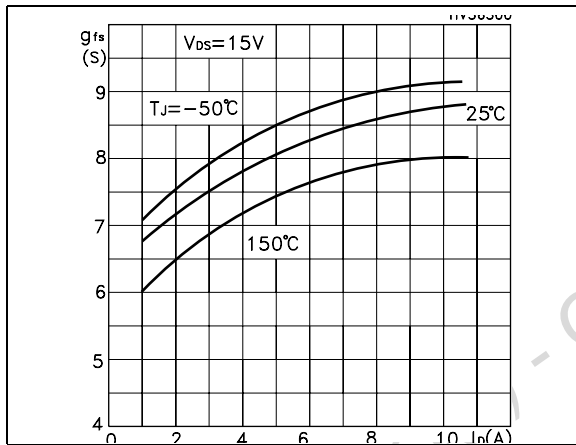

Figure 10. Static drain-source on resistance

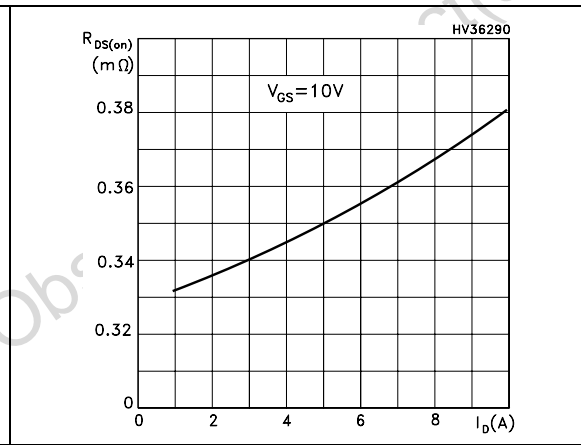

Figure 11. Gate charge vs. gate-source voltage

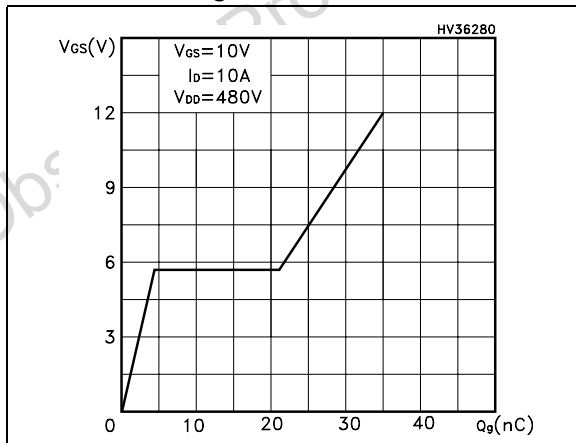

Figure 12. Capacitance variations

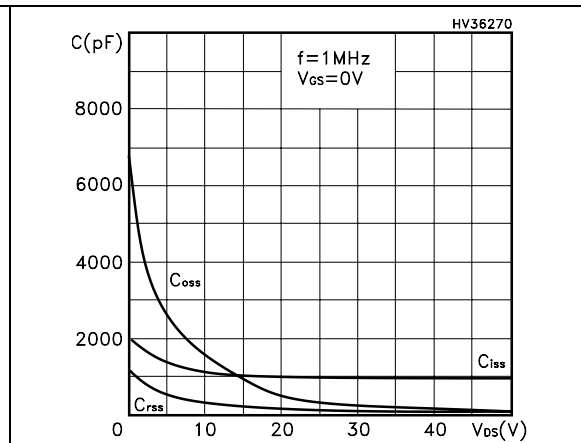

Figure 13. Normalized gate threshold voltage vs. temperature

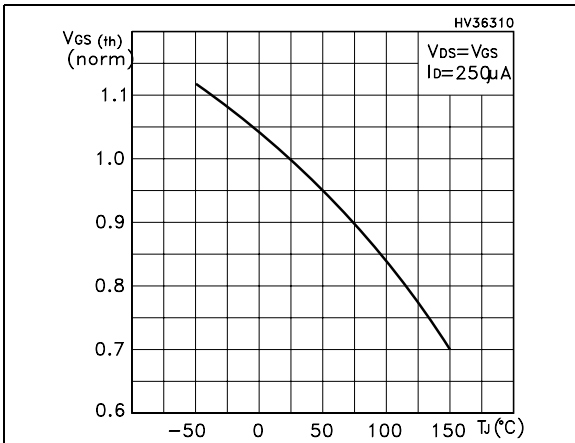

Figure 14. Normalized on resistance vs. temperature

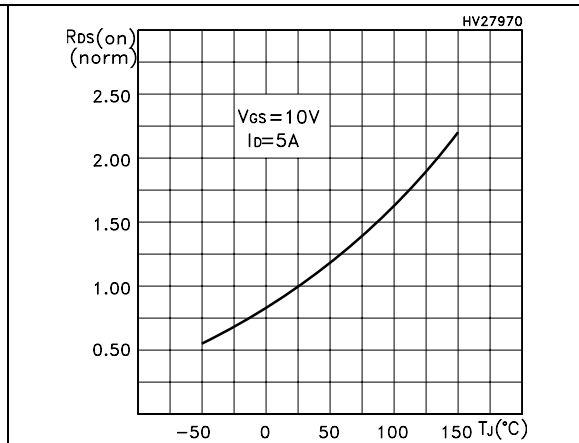

Figure 15. Source-drain diode forward characteristics

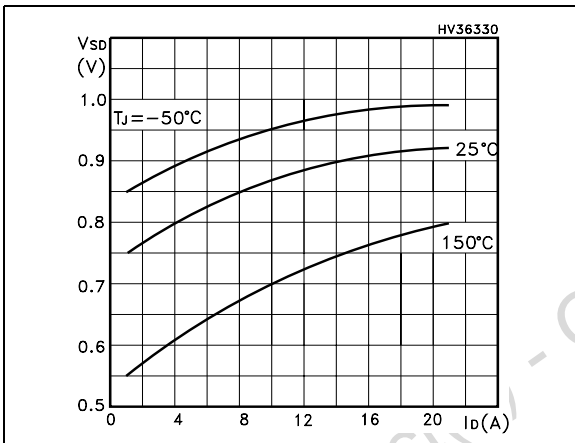
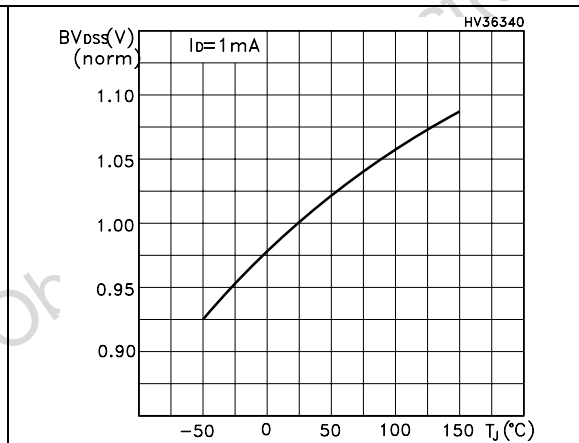

Figure 16. Normalized BV_{DSS} vs. temperature



3 Test circuit

Figure 17. Switching times test circuit for resistive load

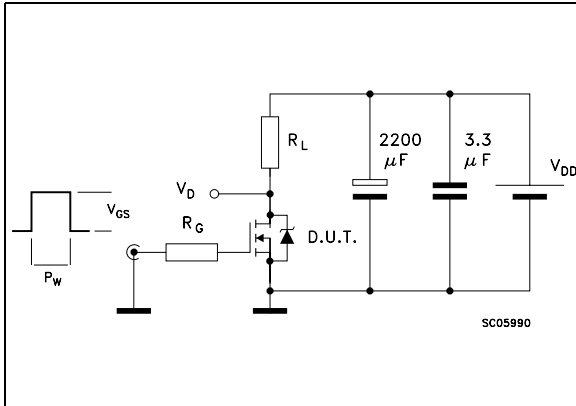

Figure 18. Gate charge test circuit

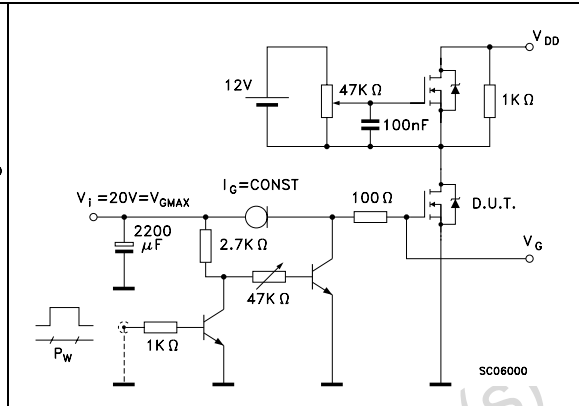

Figure 19. Test circuit for inductive load switching and diode recovery times

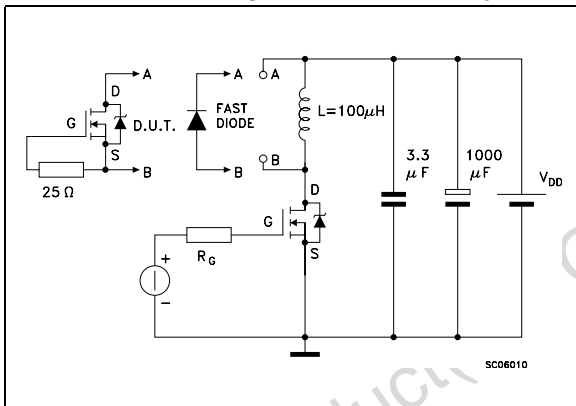

Figure 20. Unclamped Inductive load test circuit

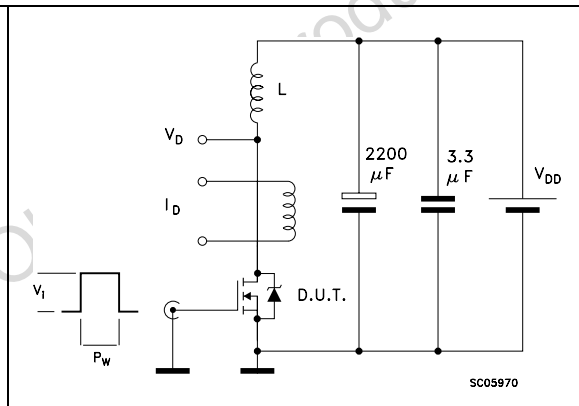

Figure 21. Unclamped inductive waveform

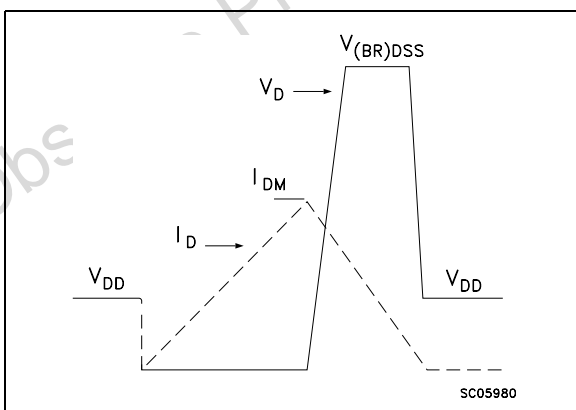
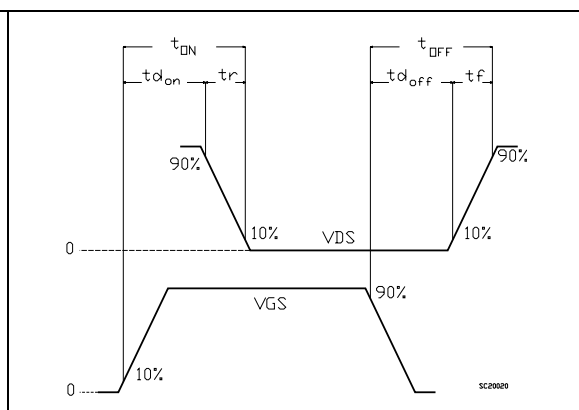

Figure 22. Switching time waveform



4 Package mechanical data

In order to meet environmental requirements, ST offers these devices in ECOPACK® packages. These packages have a Lead-free second level interconnect. The category of second level interconnect is marked on the package and on the inner box label, in compliance with JEDEC Standard JESD97. The maximum ratings related to soldering conditions are also marked on the inner box label. ECOPACK is an ST trademark. ECOPACK specifications are available at: www.st.com

Obsolete Product(s) - Obsolete Product(s)

TO-220 MECHANICAL DATA

DIM.	mm.			inch		
	MIN.	TYP	MAX.	MIN.	TYP.	MAX.
A	4.40		4.60	0.173		0.181
b	0.61		0.88	0.024		0.034
b1	1.15		1.70	0.045		0.066
c	0.49		0.70	0.019		0.027
D	15.25		15.75	0.60		0.620
E	10		10.40	0.393		0.409
e	2.40		2.70	0.094		0.106
e1	4.95		5.15	0.194		0.202
F	1.23		1.32	0.048		0.052
H1	6.20		6.60	0.244		0.256
J1	2.40		2.72	0.094		0.107
L	13		14	0.511		0.551
L1	3.50		3.93	0.137		0.154
L20		16.40			0.645	
L30		28.90			1.137	
øP	3.75		3.85	0.147		0.151
Q	2.65		2.95	0.104		0.116

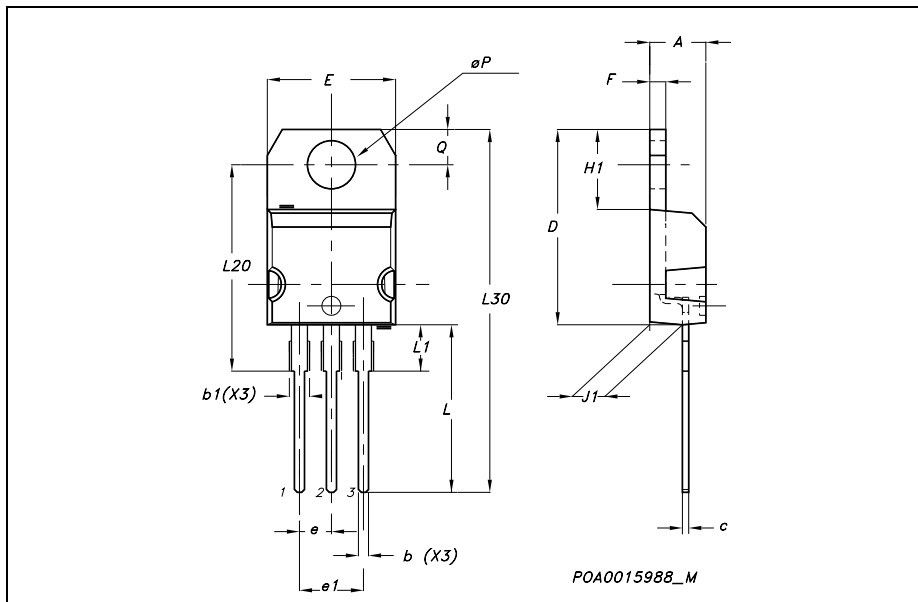

TO-220FP MECHANICAL DATA

DIM.	mm.			inch		
	MIN.	TYP	MAX.	MIN.	TYP.	MAX.
A	4.4		4.6	0.173		0.181
B	2.5		2.7	0.098		0.106
D	2.5		2.75	0.098		0.108
E	0.45		0.7	0.017		0.027
F	0.75		1	0.030		0.039
F1	1.15		1.7	0.045		0.067
F2	1.15		1.7	0.045		0.067
G	4.95		5.2	0.195		0.204
G1	2.4		2.7	0.094		0.106
H	10		10.4	0.393		0.409
L2		16			0.630	
L3	28.6		30.6	1.126		1.204
L4	9.8		10.6	.0385		0.417
L5	2.9		3.6	0.114		0.141
L6	15.9		16.4	0.626		0.645
L7	9		9.3	0.354		0.366
Ø	3		3.2	0.118		0.126

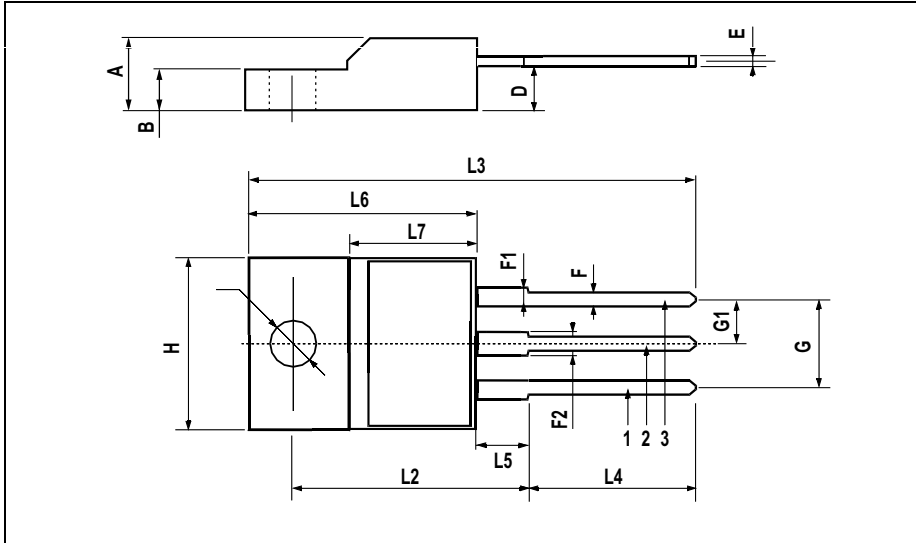

Obsole

TO-262 (I²PAK) MECHANICAL DATA

DIM.	mm.			inch		
	MIN.	TYP.	MAX.	MIN.	TYP.	MAX.
A	4.40		4.60	0.173		0.181
A1	2.40		2.72	0.094		0.107
b	0.61		0.88	0.024		0.034
b1	1.14		1.70	0.044		0.066
c	0.49		0.70	0.019		0.027
c2	1.23		1.32	0.048		0.052
D	8.95		9.35	0.352		0.368
e	2.40		2.70	0.094		0.106
e1	4.95		5.15	0.194		0.202
E	10		10.40	0.393		0.410
L	13		14	0.511		0.551
L1	3.50		3.93	0.137		0.154
L2	1.27		1.40	0.050		0.055

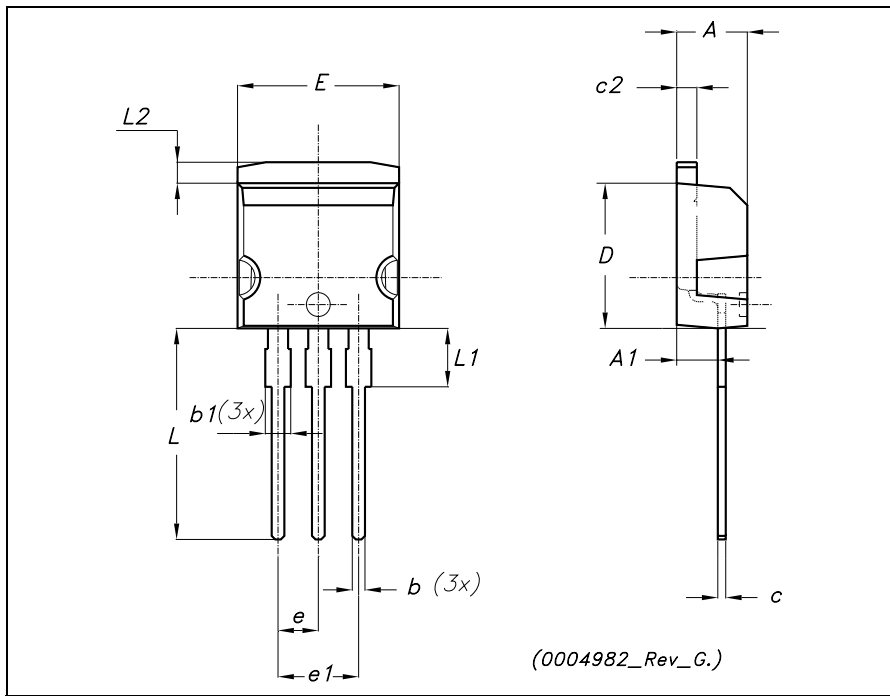

D²PAK MECHANICAL DATA

DIM.	mm.			inch		
	MIN.	TYP.	MAX.	MIN.	TYP.	MAX.
A	4.4		4.6	0.173		0.181
A1	2.49		2.69	0.098		0.106
A2	0.03		0.23	0.001		0.009
B	0.7		0.93	0.027		0.036
B2	1.14		1.7	0.044		0.067
C	0.45		0.6	0.017		0.023
C2	1.23		1.36	0.048		0.053
D	8.95		9.35	0.352		0.368
D1		8			0.315	
E	10		10.4	0.393		
E1		8.5			0.334	
G	4.88		5.28	0.192		0.208
L	15		15.85	0.590		0.625
L2	1.27		1.4	0.050		0.055
L3	1.4		1.75	0.055		0.068
M	2.4		3.2	0.094		0.126
R		0.4			0.015	
V2	0°		4°			

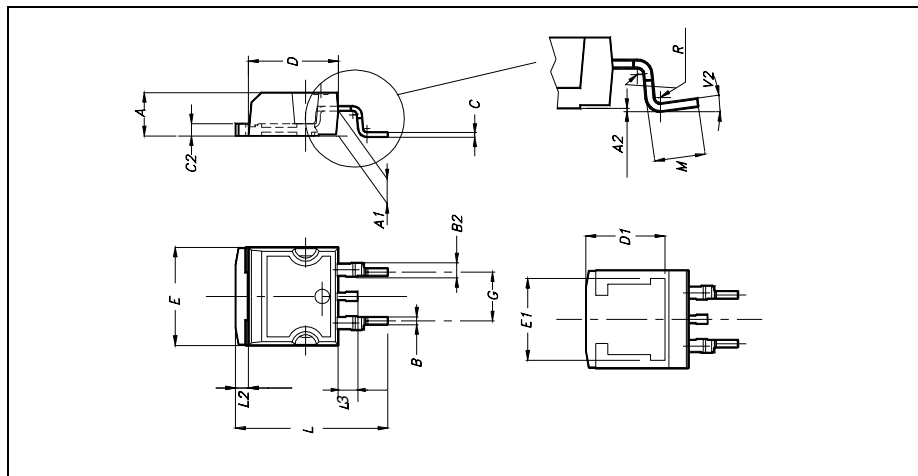

Obsole

TO-247 MECHANICAL DATA

DIM.	mm.			inch		
	MIN.	TYP.	MAX.	MIN.	TYP.	MAX.
A	4.85		5.15	0.19		0.20
A1	2.20		2.60	0.086		0.102
b	1.0		1.40	0.039		0.055
b1	2.0		2.40	0.079		0.094
b2	3.0		3.40	0.118		0.134
c	0.40		0.80	0.015		0.03
D	19.85		20.15	0.781		0.793
E	15.45		15.75	0.608		0.620
e		5.45			0.214	
L	14.20		14.80	0.560		0.582
L1	3.70		4.30	0.14		0.17
L2		18.50			0.728	
øP	3.55		3.65	0.140		0.143
øR	4.50		5.50	0.177		0.216
S		5.50			0.216	

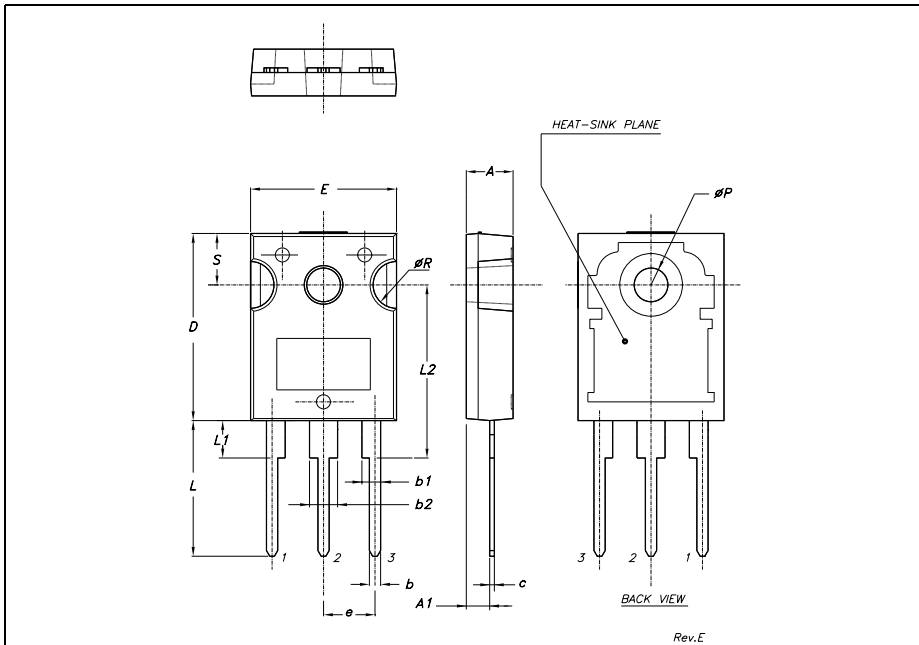

Obsolete

5 Packaging mechanical data

D²PAK FOOTPRINT

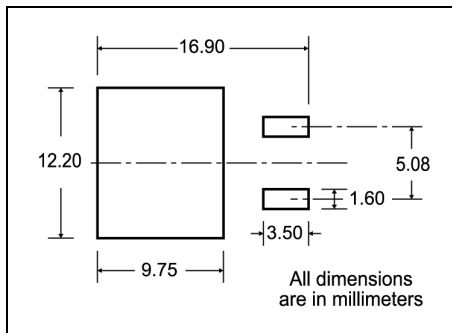

TAPE AND REEL SHIPMENT

40 mm min. Access hole at slot location

Full radius

Tape slot in core for tape start 2.5mm min. width

G measured at hub

REEL MECHANICAL DATA

DIM.	mm		inch	
	MIN.	MAX.	MIN.	MAX.
A		330		12.992
B	1.5		0.059	
C	12.8	13.2	0.504	0.520
D	20.2		0.795	
G	24.4	26.4	0.960	1.039
N	100		3.937	
T		30.4		1.197

BASE QTY	BULK QTY
1000	1000

TAPE MECHANICAL DATA

DIM.	mm		inch	
	MIN.	MAX.	MIN.	MAX.
A0	10.5	10.7	0.413	0.421
B0	15.7	15.9	0.618	0.626
D	1.5	1.6	0.059	0.063
D1	1.59	1.61	0.062	0.063
E	1.65	1.85	0.065	0.073
F	11.4	11.6	0.449	0.456
K0	4.8	5.0	0.189	0.197
P0	3.9	4.1	0.153	0.161
P1	11.9	12.1	0.468	0.476
P2	1.9	2.1	0.075	0.082
R	50		1.574	
T	0.25	0.35	0.0098	0.0137
W	23.7	24.3	0.933	0.956

TOP COVER TAPE

Center line of cavity

User Direction of Feed

FEED DIRECTION

Bending radius R min.

* on sales type

6 Revision history

Table 8. Revision history

Date	Revision	Changes
26-Mar-2007	1	First release
23-Apr-2007	2	Complete version

Obsolete Product(s) - Obsolete Product(s)

Please Read Carefully:

Information in this document is provided solely in connection with ST products. STMicroelectronics NV and its subsidiaries ("ST") reserve the right to make changes, corrections, modifications or improvements, to this document, and the products and services described herein at any time, without notice.

All ST products are sold pursuant to ST's terms and conditions of sale.

Purchasers are solely responsible for the choice, selection and use of the ST products and services described herein, and ST assumes no liability whatsoever relating to the choice, selection or use of the ST products and services described herein.

No license, express or implied, by estoppel or otherwise, to any intellectual property rights is granted under this document. If any part of this document refers to any third party products or services it shall not be deemed a license grant by ST for the use of such third party products or services, or any intellectual property contained therein or considered as a warranty covering the use in any manner whatsoever of such third party products or services or any intellectual property contained therein.

UNLESS OTHERWISE SET FORTH IN ST'S TERMS AND CONDITIONS OF SALE ST DISCLAIMS ANY EXPRESS OR IMPLIED WARRANTY WITH RESPECT TO THE USE AND/OR SALE OF ST PRODUCTS INCLUDING WITHOUT LIMITATION IMPLIED WARRANTIES OF MERCHANTABILITY, FITNESS FOR A PARTICULAR PURPOSE (AND THEIR EQUIVALENTS UNDER THE LAWS OF ANY JURISDICTION), OR INFRINGEMENT OF ANY PATENT, COPYRIGHT OR OTHER INTELLECTUAL PROPERTY RIGHT.

UNLESS EXPRESSLY APPROVED IN WRITING BY AN AUTHORIZED ST REPRESENTATIVE, ST PRODUCTS ARE NOT RECOMMENDED, AUTHORIZED OR WARRANTED FOR USE IN MILITARY, AIR CRAFT, SPACE, LIFE SAVING, OR LIFE SUSTAINING APPLICATIONS, NOR IN PRODUCTS OR SYSTEMS WHERE FAILURE OR MALFUNCTION MAY RESULT IN PERSONAL INJURY, DEATH, OR SEVERE PROPERTY OR ENVIRONMENTAL DAMAGE. ST PRODUCTS WHICH ARE NOT SPECIFIED AS "AUTOMOTIVE GRADE" MAY ONLY BE USED IN AUTOMOTIVE APPLICATIONS AT USER'S OWN RISK.

Resale of ST products with provisions different from the statements and/or technical features set forth in this document shall immediately void any warranty granted by ST for the ST product or service described herein and shall not create or extend in any manner whatsoever, any liability of ST.

ST and the ST logo are trademarks or registered trademarks of ST in various countries.

Information in this document supersedes and replaces all information previously supplied.

The ST logo is a registered trademark of STMicroelectronics. All other names are the property of their respective owners.



© 2007 STMicroelectronics - All rights reserved

STMicroelectronics group of companies

Australia - Belgium - Brazil - Canada - China - Czech Republic - Finland - France - Germany - Hong Kong - India - Israel - Italy - Japan - Malaysia - Malta - Morocco - Singapore - Spain - Sweden - Switzerland - United Kingdom - United States of America

www.st.com