

# IRF7805QPbF

- Advanced Process Technology
- Ultra Low On-Resistance
- N Channel MOSFET
- Surface Mount
- Available in Tape & Reel
- 150°C Operating Temperature
- Lead-Free

## Description

These HEXFET® Power MOSFET's in package utilize the latest processing techniques to achieve extremely low on-resistance per silicon area. Additional features of these HEXFET Power MOSFET's are a 150°C junction operating temperature, fast switching speed and improved repetitive avalanche rating. These benefits combine to make this design an extremely efficient and reliable device for use in a wide variety of applications. The efficient SO-8 package provides enhanced thermal characteristics making it ideal in a variety of power applications. This surface mount SO-8 can dramatically reduce board space and is also available in Tape & Reel.

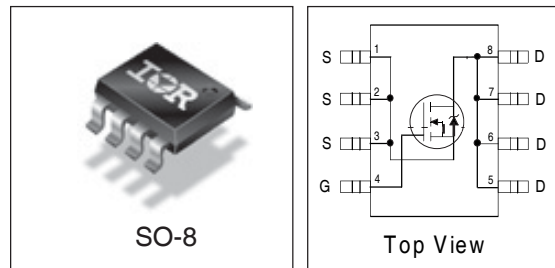

### Device Features

	IRF7805Q
$V_{DS}$	30V
$R_{DS(on)}$	11mΩ
$Q_g$	31nC
$Q_{sw}$	11.5nC
$Q_{oss}$	36nC

## Absolute Maximum Ratings

	Parameter	Max.	Units
$V_{DS}$	Drain-to-Source Voltage	30	V
$V_{GS}$	Gate-to-Source Voltage	± 12	
$I_D @ T_A = 25^\circ\text{C}$	Continuous Drain Current, $V_{GS} @ 10\text{V}$	13	A
$I_D @ T_A = 70^\circ\text{C}$	Continuous Drain Current, $V_{GS} @ 10\text{V}$	10	
$I_{DM}$	Pulsed Drain Current <sup>①</sup>	100	
$P_D @ T_A = 25^\circ\text{C}$	Power Dissipation <sup>②</sup>	2.5	W
$P_D @ T_A = 70^\circ\text{C}$	Power Dissipation <sup>②</sup>	1.6	
	Linear Derating Factor	0.02	W/°C
$T_J$	Operating Junction and	-55 to + 150	°C
$T_{STG}$	Storage Temperature Range		

## Thermal Resistance

	Parameter	Typ.	Max.	Units
$R_{\theta JL}$	Junction-to-Drain Lead <sup>③</sup>	—	20	°C/W
$R_{\theta JA}$	Junction-to-Ambient <sup>③④</sup>	—	50	

## Static @ $T_J = 25^\circ\text{C}$ (unless otherwise specified)

	Parameter	Min.	Typ.	Max.	Units	Conditions
$BV_{DSS}$	Drain-to-Source Breakdown Voltage <sup>⑥</sup>	30	—	—	V	$V_{GS} = 0V, I_D = 250\mu A$
$R_{DS(on)}$	Static Drain-to-Source On-Resistance <sup>⑥</sup>	—	9.2	11	m $\Omega$	$V_{GS} = 4.5V, I_D = 7.0A$ <sup>②</sup>
$V_{GS(th)}$	Gate Threshold Voltage <sup>⑥</sup>	1.0	—	3.0	V	$V_{DS} = V_{GS}, I_D = 250\mu A$
$I_{DSS}$	Drain-to-Source Leakage Current	—	—	70	$\mu A$	$V_{DS} = 30V, V_{GS} = 0V$
		—	—	10		$V_{DS} = 24V, V_{GS} = 0V$
		—	—	150		$V_{DS} = 24V, V_{GS} = 0V, T_J = 100^\circ\text{C}$
$I_{GSS}$	Gate-to-Source Forward Leakage	—	—	100	nA	$V_{GS} = 12V$
	Gate-to-Source Reverse Leakage	—	—	-100		$V_{GS} = -12V$
$Q_g$	Total Gate Charge	—	22	31	nC	$V_{GS} = 5.0V$
$Q_{gs1}$	Pre-V <sub>th</sub> Gate-to-Source Charge	—	3.7	—		$V_{DS} = 16V$
$Q_{gs2}$	Post-V <sub>th</sub> Gate-to-Source Charge	—	1.4	—		$I_D = 7.0A$
$Q_{gd}$	Gate-to-Drain Charge	—	6.8	—		
$Q_{sw}$	Switch Charge ( $Q_{gs2} + Q_{gd}$ )	—	8.2	11.5		
$Q_{oss}$	Output Charge	—	3.0	3.6	nC	$V_{DS} = 16V, V_{GS} = 0V$
$R_G$	Gate Resistance	0.5	—	1.7	$\Omega$	
$t_{d(on)}$	Turn-On Delay Time	—	16	—	ns	$V_{DD} = 16V, V_{GS} = 4.5V$ <sup>③</sup>
$t_r$	Rise Time	—	20	—		$I_D = 7.0A$
$t_{d(off)}$	Turn-Off Delay Time	—	38	—		$R_G = 2\Omega$
$t_f$	Fall Time	—	16	—		Resistive Load

## Diode Characteristics

	Parameter	Min.	Typ.	Max.	Units	Conditions
$I_S$	Continuous Source Current (Body Diode) <sup>①</sup>	—	—	2.5	A	MOSFET symbol showing the integral reverse p-n junction diode.
$I_{SM}$	Pulsed Source Current (Body Diode)	—	—	106		
$V_{SD}$	Diode Forward Voltage <sup>⑥</sup>	—	—	1.2	V	$T_J = 25^\circ\text{C}, I_S = 7.0A, V_{GS} = 0V$
$Q_{rr}$	Reverse Recovery Charge <sup>④</sup>	—	88	—	ns	$di/dt = 700A/\mu s$ $V_{DS} = 16V, V_{GS} = 0V, I_S = 7.0A$
$Q_{rr(s)}$	Reverse Recovery Charge (with Parallel Schottky) <sup>④</sup>	—	55	—	nC	$di/dt = 700A/\mu s$ (with 10BQ040) $V_{DS} = 16V, V_{GS} = 0V, I_S = 7.0A$

### Notes:

- ① Repetitive rating; pulse width limited by max. junction temperature.
- ② Pulse width  $\leq 300 \mu s$ ; duty cycle  $\leq 2\%$ .
- ③ When mounted on 1 inch square copper board,  $t < 10$  sec.
- ④ Typ = measured -  $Q_{oss}$ .
- ⑤  $R_g$  is measured at  $T_J$  of approximately  $90^\circ\text{C}$ .
- ⑥ Devices are 100% tested to these parameters.

## Typical Characteristics

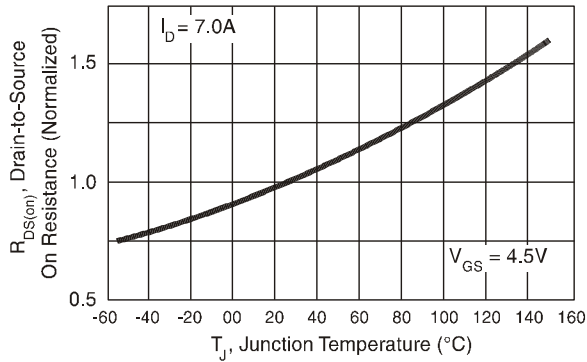

Fig 1. Normalized On-Resistance vs. Temperature

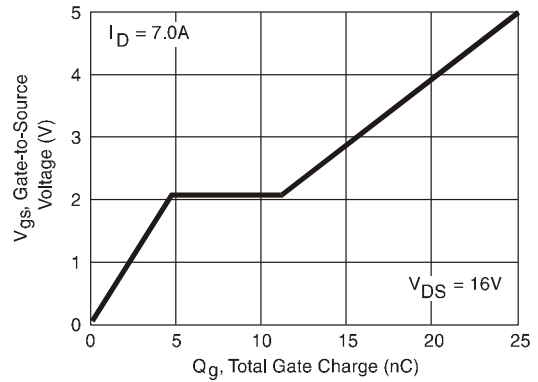

Fig 2. Typical Gate Charge vs. Gate-to-Source Voltage

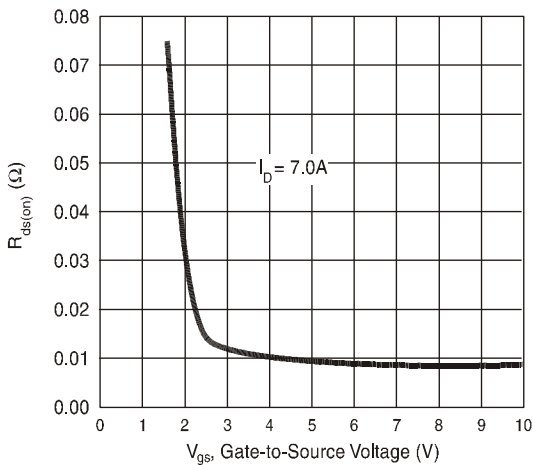

Fig 3. Typical  $R_{DS(on)}$  vs. Gate-to-Source Voltage

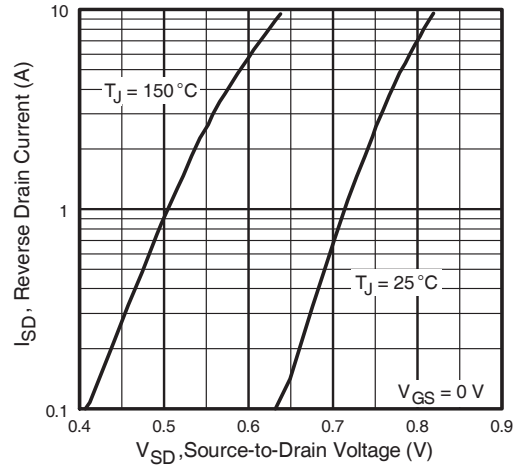

Fig 4. Typical Source-Drain Diode Forward Voltage

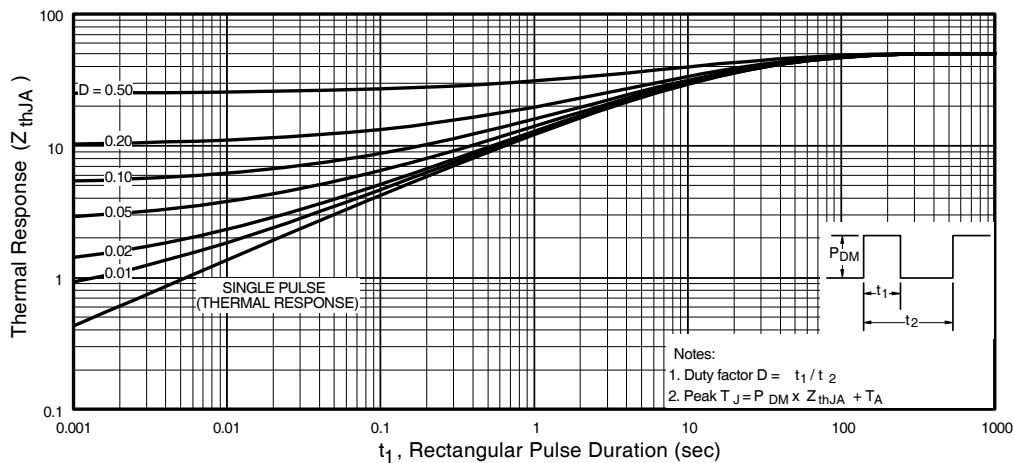

Figure 5. Maximum Effective Transient Thermal Impedance, Junction-to-Ambient

# IRF7805QPbF

International  
**IR** Rectifier

## SO-8 Package Outline

Dimensions are shown in millimeters (inches)

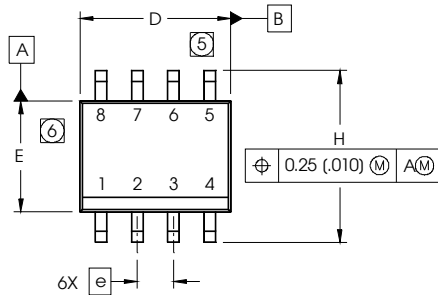

DIM	INCHES		MILLIMETERS	
	MIN	MAX	MIN	MAX
A	.0532	.0688	1.35	1.75
A1	.0040	.0098	0.10	0.25
b	.013	.020	0.33	0.51
c	.0075	.0098	0.19	0.25
D	.189	.1968	4.80	5.00
E	.1497	.1574	3.80	4.00
e	.050 BASIC		1.27 BASIC	
e1	.025 BASIC		0.635 BASIC	
H	.2284	.2440	5.80	6.20
K	.0099	.0196	0.25	0.50
L	.016	.050	0.40	1.27
y	0°	8°	0°	8°

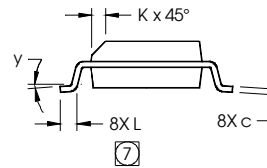
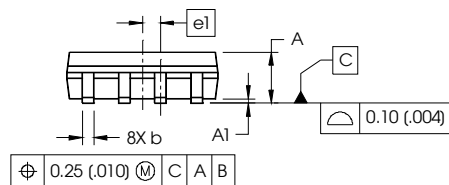

### NOTES:

1. DIMENSIONING & TOLERANCING PER ASME Y14.5M-1994.
2. CONTROLLING DIMENSION: MILLIMETER
3. DIMENSIONS ARE SHOWN IN MILLIMETERS (INCHES).
4. OUTLINE CONFORMS TO JEDEC OUTLINE MS-012AA.
- ⑤ DIMENSION DOES NOT INCLUDE MOLD PROTRUSIONS. MOLD PROTRUSIONS NOT TO EXCEED 0.15 (.006).
- ⑥ DIMENSION DOES NOT INCLUDE MOLD PROTRUSIONS. MOLD PROTRUSIONS NOT TO EXCEED 0.25 (.010).
- ⑦ DIMENSION IS THE LENGTH OF LEAD FOR SOLDERING TO A SUBSTRATE.

### FOOTPRINT

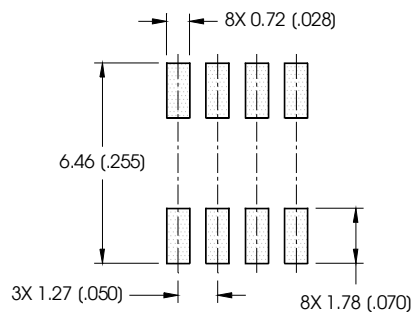

## SO-8 Part Marking

EXAMPLE: THIS IS AN IRF7101 (MOSFET)

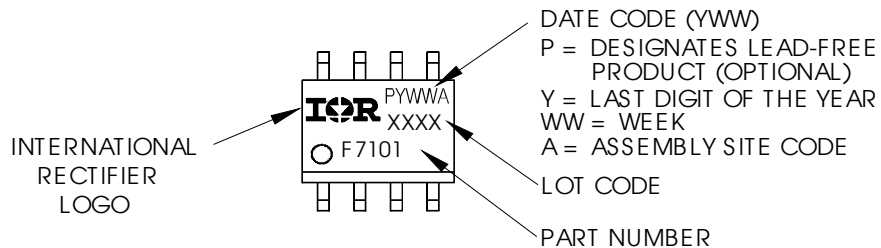

### Notes:

1. For an Automotive Qualified version of this part please see <http://www.irf.com/product-info/auto/>
2. For the most current drawing please refer to IR website at <http://www.irf.com/package/>

4

www.irf.com

## SO-8 Tape and Reel

Dimensions are shown in millimeters (inches)

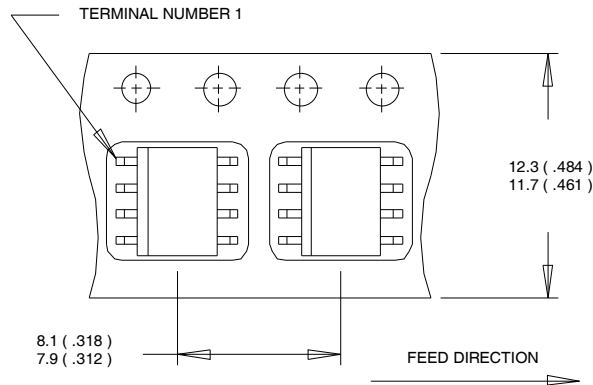

**NOTES:**

1. CONTROLLING DIMENSION : MILLIMETER.
2. ALL DIMENSIONS ARE SHOWN IN MILLIMETERS(INCHES).
3. OUTLINE CONFORMS TO EIA-481 & EIA-541.

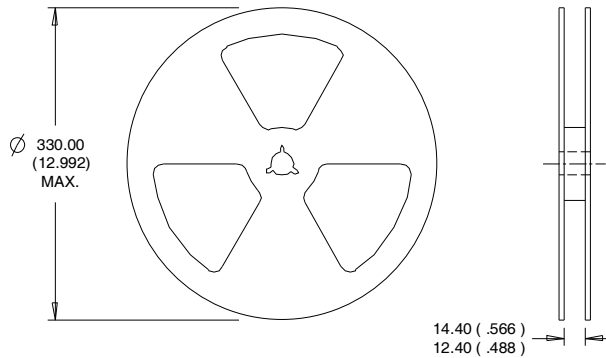

**NOTES :**

1. CONTROLLING DIMENSION : MILLIMETER.
2. OUTLINE CONFORMS TO EIA-481 & EIA-541.

Data and specifications subject to change without notice.  
 This product has been designed and qualified for the Industrial market.  
 Qualification Standards can be found on IR's Web site.