



# STD60N3LH5, STP60N3LH5 STU60N3LH5, STU60N3LH5-S

N-channel 30 V, 0.0072  $\Omega$ , 48 A DPAK, IPAK, Short IPAK, TO-220  
STripFET™ V Power MOSFET

## Features

Order codes	V <sub>DSS</sub>	R <sub>DS(on)</sub> max	I <sub>D</sub>
STD60N3LH5	30 V	0.008 $\Omega$	48 A
STP60N3LH5	30 V	0.0084 $\Omega$	48 A
STU60N3LH5	30 V	0.0084 $\Omega$	48 A
STU60N3LH5-S	30 V	0.0084 $\Omega$	48 A

- R<sub>DS(on)</sub> \* Q<sub>g</sub> industry benchmark
- Extremely low on-resistance R<sub>DS(on)</sub>
- Very low switching gate charge
- High avalanche ruggedness
- Low gate drive power losses

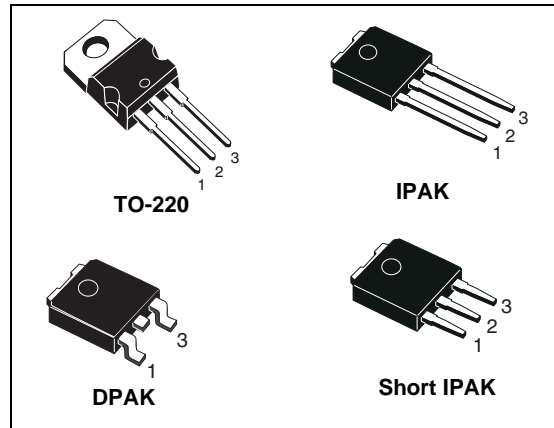

## Application

Switching applications

## Description

This STripFET™V Power MOSFET technology is among the latest improvements, which have been especially tailored to achieve very low on-state resistance providing also one of the best-in-class figure of merit.

Figure 1. Internal schematic diagram

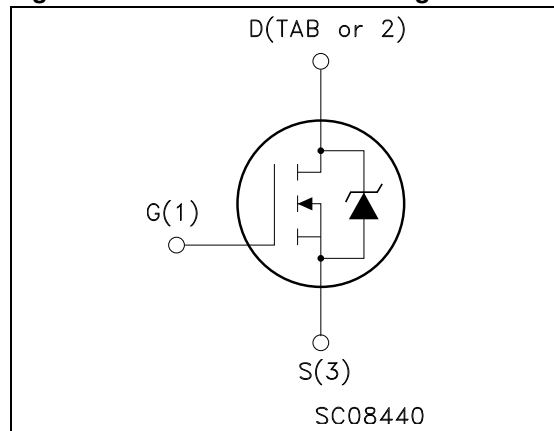

Table 1. Device summary

Order codes	Marking	Package	Packaging
STD60N3LH5	60N3LH5	DPAK	Tape and reel
STP60N3LH5	60N3LH5	TO-220	Tube
STU60N3LH5	60N3LH5	IPAK	
STU60N3LH5-S	60N3LH5	Short IPAK	

## Contents

<b>1</b>	<b>Electrical ratings</b> .....	<b>3</b>
<b>2</b>	<b>Electrical characteristics</b> .....	<b>4</b>
	2.1 Electrical characteristics (curves) .....	6
<b>3</b>	<b>Test circuits</b> .....	<b>8</b>
<b>4</b>	<b>Package mechanical data</b> .....	<b>10</b>
<b>5</b>	<b>Packaging mechanical data</b> .....	<b>18</b>
<b>6</b>	<b>Revision history</b> .....	<b>20</b>

# 1 Electrical ratings

**Table 2. Absolute maximum ratings**

Symbol	Parameter	Value	Unit
$V_{DS}$	Drain-source voltage ( $V_{GS} = 0$ )	30	V
$V_{DS}$	Drain-source voltage ( $V_{GS} = 0$ ) @ $T_{JMAX}$	35	V
$V_{GS}$	Gate-Source voltage	$\pm 20$	V
$I_D^{(1)}$	Drain current (continuous) at $T_C = 25\text{ }^\circ\text{C}$	48	A
$I_D$	Drain current (continuous) at $T_C = 100\text{ }^\circ\text{C}$	42.8	A
$I_{DM}^{(2)}$	Drain current (pulsed)	192	A
$P_{TOT}$	Total dissipation at $T_C = 25\text{ }^\circ\text{C}$	60	W
	Derating factor	0.4	W/ $^\circ\text{C}$
$E_{AS}^{(3)}$	Single pulse avalanche energy	160	mJ
$T_j$ $T_{stg}$	Operating junction temperature Storage temperature	-55 to 175	$^\circ\text{C}$

1. Limited by wire bonding.
2. Pulse width limited by safe operating area.
3. Starting  $T_j = 25\text{ }^\circ\text{C}$ ,  $I_D = 24\text{ A}$ ,  $V_{DD} = 12\text{ V}$ .

**Table 3. Thermal resistance**

Symbol	Parameter	Value	Unit
$R_{thj-case}$	Thermal resistance junction-case max.	2.5	$^\circ\text{C/W}$
$R_{thj-amb}$	Thermal resistance junction-case max.	100	$^\circ\text{C/W}$
$T_j$	Maximum lead temperature for soldering purpose	275	$^\circ\text{C}$

## 2 Electrical characteristics

( $T_{CASE} = 25\text{ °C}$  unless otherwise specified)

**Table 4. Static**

Symbol	Parameter	Test conditions	Min.	Typ.	Max.	Unit
$V_{(BR)DSS}$	Drain-source breakdown Voltage	$I_D = 250\ \mu\text{A}$ , $V_{GS} = 0$	30			V
$I_{DSS}$	Zero gate voltage drain current ( $V_{GS} = 0$ )	$V_{DS} = 30\text{ V}$ $V_{DS} = 30\text{ V}$ , $T_c = 125\text{ °C}$			1 10	$\mu\text{A}$ $\mu\text{A}$
$I_{GSS}$	Gate body leakage current ( $V_{DS} = 0$ )	$V_{GS} = \pm 20\text{ V}$			$\pm 100$	nA
$V_{GS(th)}$	Gate threshold voltage	$V_{DS} = V_{GS}$ , $I_D = 250\ \mu\text{A}$	1	1.8	3	V
$R_{DS(on)}$	Static drain-source on resistance	$V_{GS} = 10\text{ V}$ , $I_D = 24\text{ A}$ SMD version		0.0072	0.008	$\Omega$
		$V_{GS} = 10\text{ V}$ , $I_D = 24\text{ A}$		0.0076	0.0084	$\Omega$
		$V_{GS} = 5\text{ V}$ , $I_D = 24\text{ A}$ SMD version		0.0088	0.011	$\Omega$
		$V_{GS} = 5\text{ V}$ , $I_D = 24\text{ A}$		0.0092	0.0114	$\Omega$

**Table 5. Dynamic**

Symbol	Parameter	Test conditions	Min.	Typ.	Max.	Unit
$C_{iss}$	Input capacitance	$V_{DS} = 25\text{ V}$ , $f = 1\text{ MHz}$ , $V_{GS} = 0$		1350	1620	pF
$C_{oss}$	Output capacitance		-	265	318	pF
$C_{rss}$	Reverse transfer capacitance			32	38	pF
$Q_g$	Total gate charge	$V_{DD} = 15\text{ V}$ , $I_D = 48\text{ A}$		8.8	12.3	nC
$Q_{gs}$	Gate-source charge	$V_{GS} = 5\text{ V}$	-	4.7	6.6	nC
$Q_{gd}$	Gate-drain charge	( <i>Figure 14</i> )		2.2	3.1	nC
$Q_{gs1}$	Pre $V_{th}$ gate-to-source charge	$V_{DD} = 15\text{ V}$ , $I_D = 48\text{ A}$		2.2	3.1	nC
$Q_{gs2}$	Post $V_{th}$ gate-to-source charge	$V_{GS} = 5\text{ V}$ ( <i>Figure 19</i> )	-	2.5	3.5	nC
$R_G$	Gate input resistance	$f = 1\text{ MHz}$ gate bias Bias = 0 test signal level = 20 mV open drain	-	1.1	1.3	$\Omega$

Table 6. Switching on/off (resistive load)

Symbol	Parameter	Test conditions	Min.	Typ.	Max.	Unit
$t_{d(on)}$	Turn-on delay time	$V_{DD}=10\text{ V}$ , $I_D=24\text{ A}$ , $R_G=4.7\ \Omega$ , $V_{GS}=10\text{ V}$ ( <i>Figure 13</i> and <i>Figure 18</i> )	-	6	-	ns
$t_r$	Rise time			33		
$t_{d(off)}$	Turn-off delay time	$V_{DD}=10\text{ V}$ , $I_D=24\text{ A}$ , $R_G=4.7\ \Omega$ , $V_{GS}=10\text{ V}$ ( <i>Figure 13</i> and <i>Figure 18</i> )	-	19	-	ns
$t_f$	Fall time			4.2		

Table 7. Source drain diode

Symbol	Parameter	Test conditions	Min.	Typ.	Max.	Unit	
$I_{SD}$	Source-drain current		-		48	A	
$I_{SDM}$	Source-drain current (pulsed) <sup>(1)</sup>				192	A	
$V_{SD}$	Forward on voltage	$I_{SD}=24\text{ A}$ , $V_{GS}=0$	-		1.1	V	
$t_{rr}$	Reverse recovery time	$I_{SD}=48\text{ A}$ , $di/dt=100\text{ A}/\mu\text{s}$ , $V_{DD}=20\text{ V}$ , ( <i>Figure 15</i> )	-	25		ns	
$Q_{rr}$	Reverse recovery charge			18.5			nC
$I_{RRM}$	Reverse recovery current			1.5			A

1. Pulsed: pulse duration = 300 $\mu\text{s}$ , duty cycle 1.5%

## 2.1 Electrical characteristics (curves)

Figure 2. Safe operating area

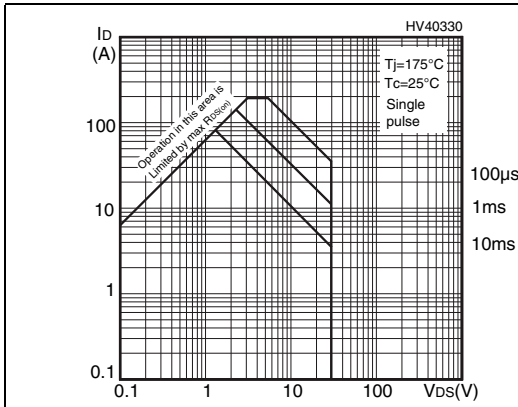

Figure 3. Thermal impedance

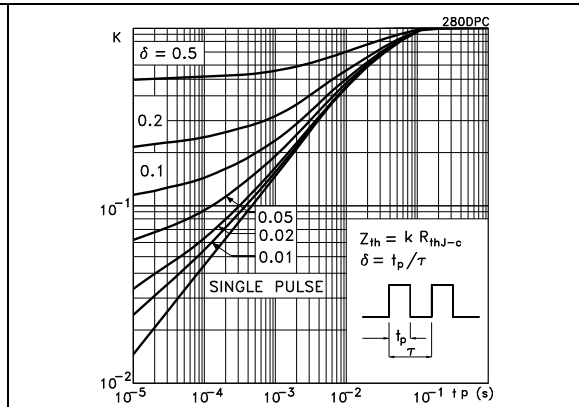

Figure 4. Output characteristics

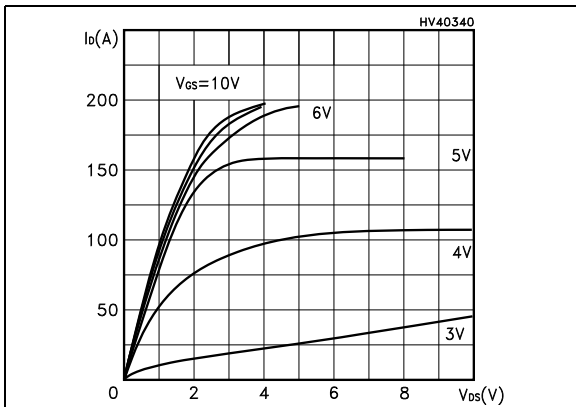

Figure 5. Transfer characteristics

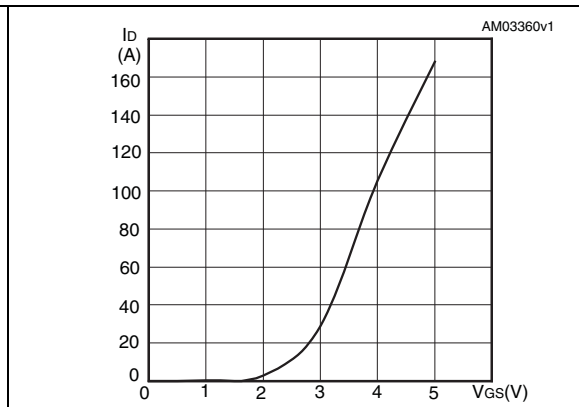

Figure 6. Normalized BV<sub>DSS</sub> vs temperature

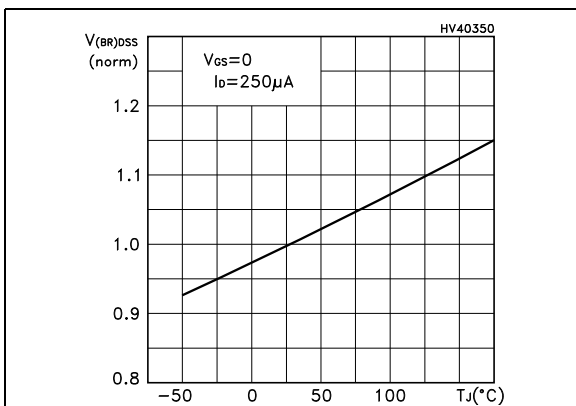

Figure 7. Static drain-source on resistance

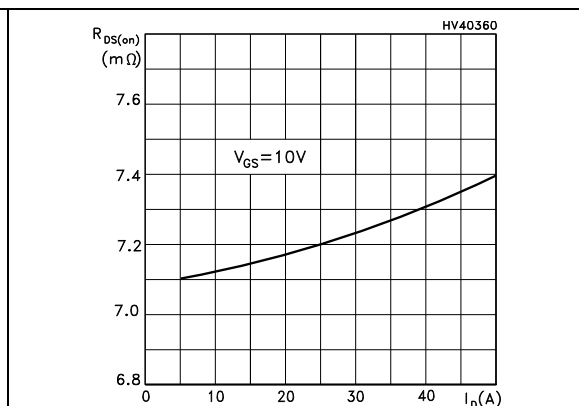

Figure 8. Gate charge vs gate-source voltage Figure 9. Capacitance variations

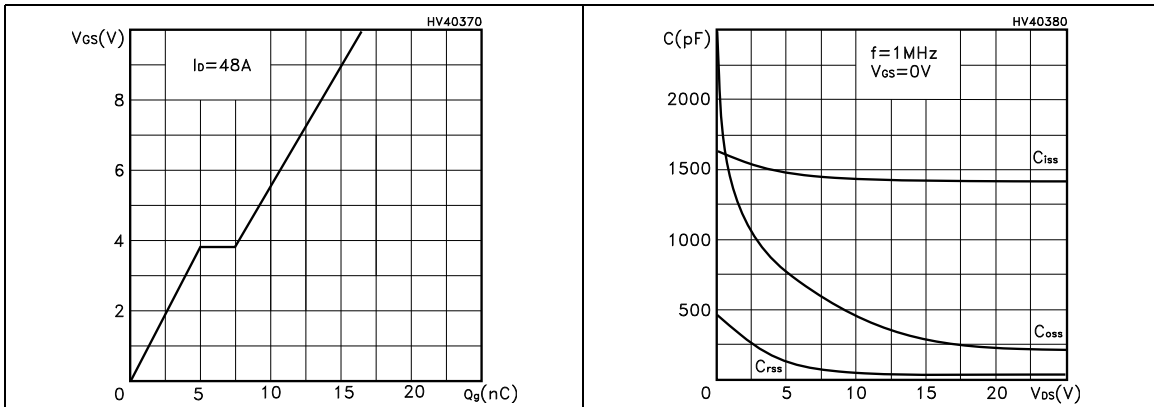

Figure 10. Normalized gate threshold voltage vs temperature Figure 11. Normalized on resistance vs temperature

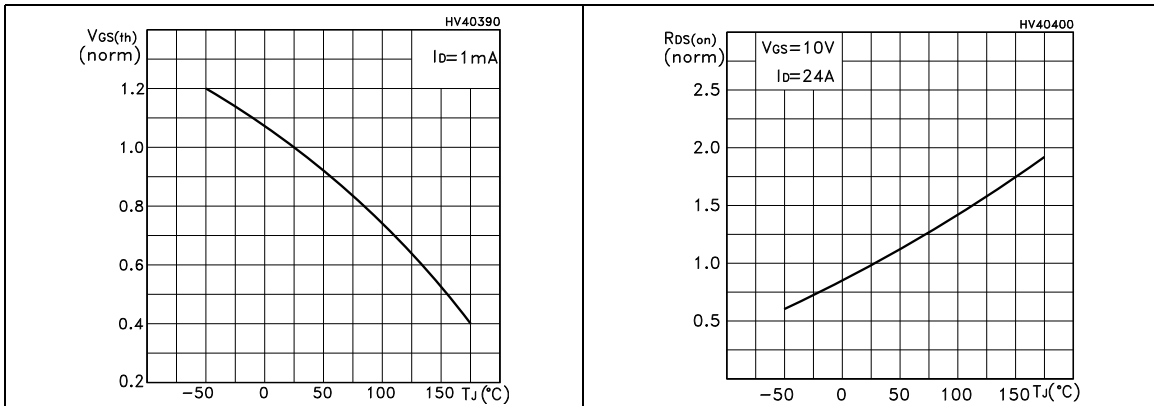
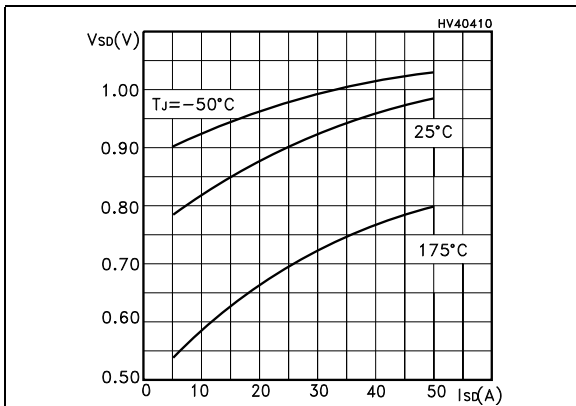

Figure 12. Source-drain diode forward characteristics



### 3 Test circuits

Figure 13. Switching times test circuit for resistive load

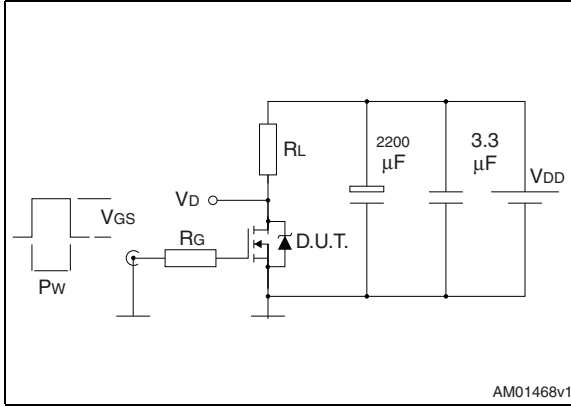

Figure 14. Gate charge test circuit

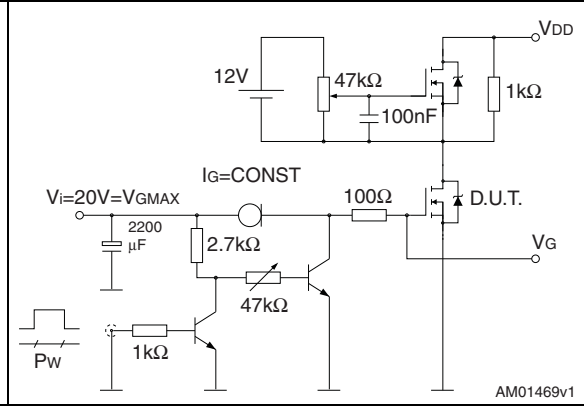

Figure 15. Test circuit for inductive load switching and diode recovery times

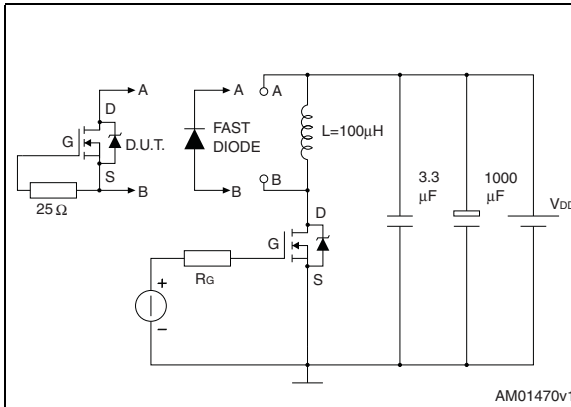

Figure 16. Unclamped inductive load test circuit

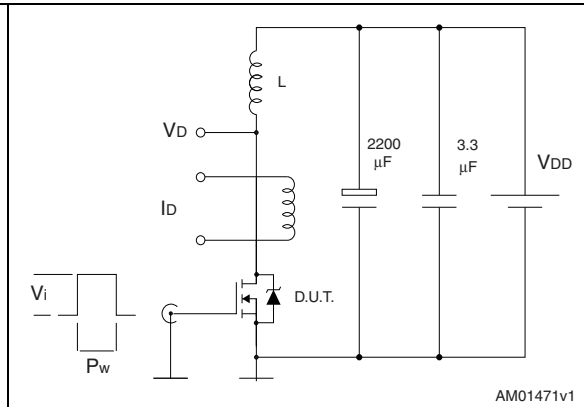

Figure 17. Unclamped inductive waveform

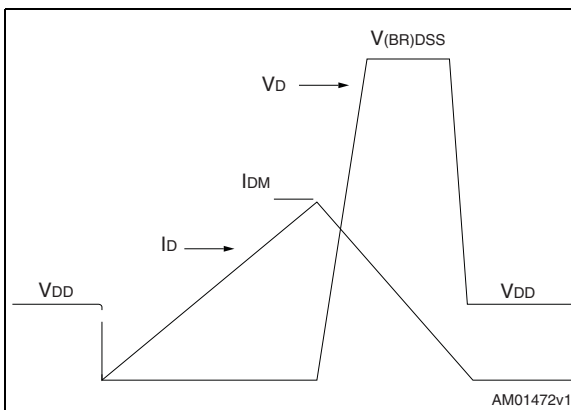

Figure 18. Switching time waveform

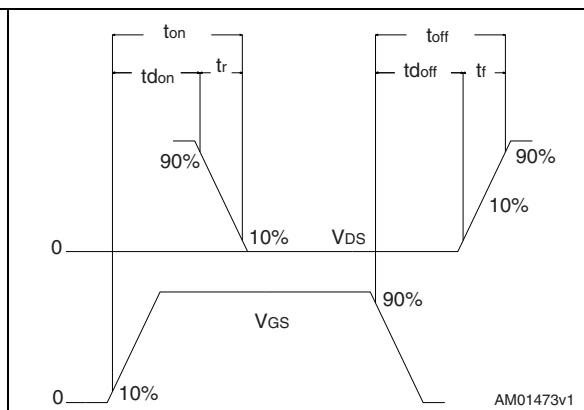
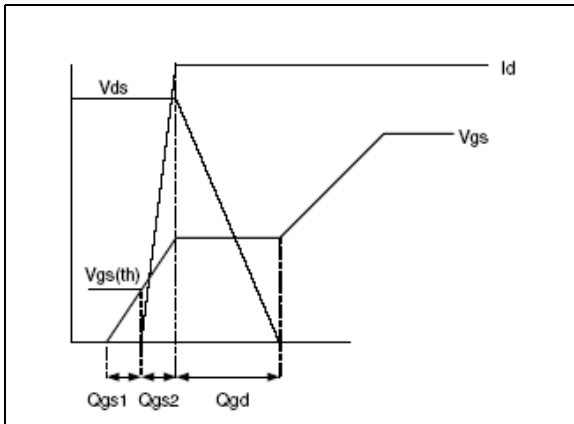



Figure 19. Gate charge waveform



## 4 Package mechanical data

In order to meet environmental requirements, ST offers these devices in different grades of ECOPACK<sup>®</sup> packages, depending on their level of environmental compliance. ECOPACK<sup>®</sup> specifications, grade definitions and product status are available at: [www.st.com](http://www.st.com). ECOPACK is an ST trademark.

Table 8. Short IPAК mechanical dimensions

Dim.	mm		
	Min.	Typ.	Max.
A	2.20		2.40
A1	0.90		1.10
b	0.64		0.90
b2			0.95
b4	5.20		5.40
c	0.45		0.60
c2	0.48		0.60
D	6.00		6.20
E	6.40		6.60
e		2.25	
e1	4.40		4.60
H	9.80		10.40
L	3.00		3.40
L1	0.80		1.20
L2		0.80	1.00

Figure 20. Short IPAК mechanical drawing

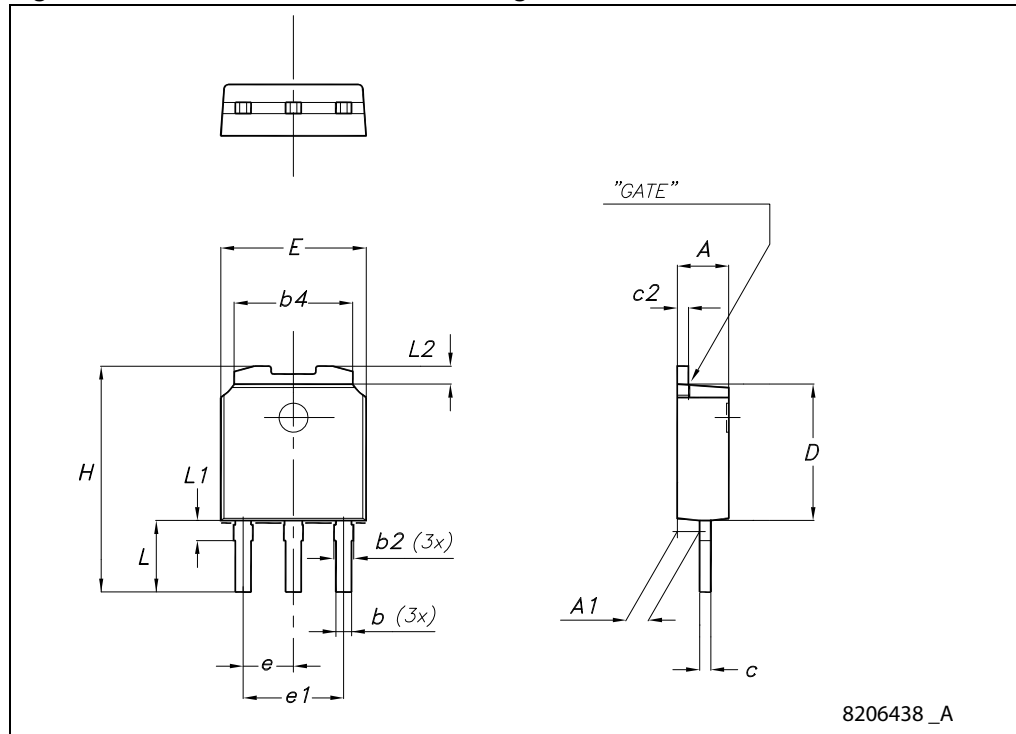
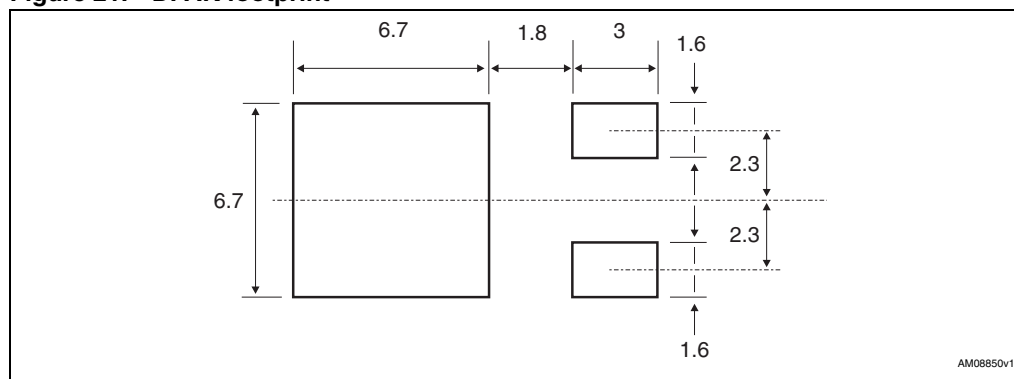

Table 9. DPAK (TO-252) mechanical data

Dim.	mm		
	Min.	Typ.	Max.
A	2.20		2.40
A1	0.90		1.10
A2	0.03		0.23
b	0.64		0.90
b4	5.20		5.40
c	0.45		0.60
c2	0.48		0.60
D	6.00		6.20
D1		5.10	
E	6.40		6.60
E1		4.70	
e		2.28	
e1	4.40		4.60
H	9.35		10.10
L	1		
L1		2.80	
L2		0.80	
L4	0.60		1
R		0.20	
V2	0°		8°

Figure 21. DPAK footprint<sup>(a)</sup>



a. All dimension are in millimeters

Figure 22. DPAK (TO-252) drawing

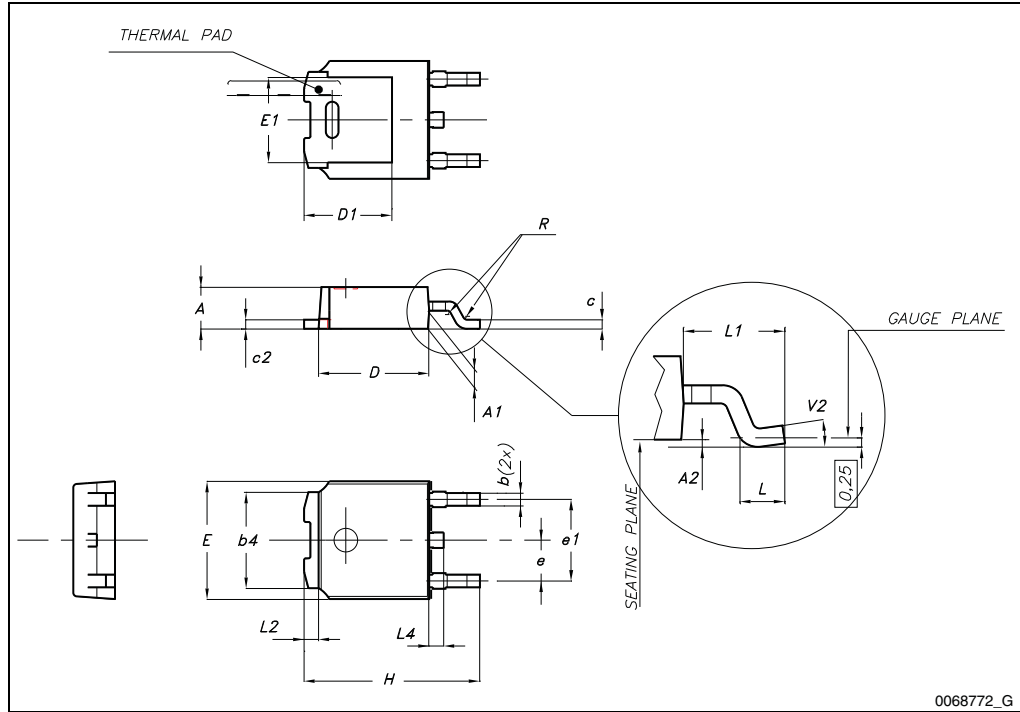

Table 10. IPAK (TO-251) mechanical data

Dim.	mm.		
	Min.	Typ.	Max.
A	2.20		2.40
A1	0.90		1.10
b	0.64		0.90
b2			0.95
b4	5.20		5.40
B5		0.3	
c	0.45		0.60
c2	0.48		0.60
D	6.00		6.20
E	6.40		6.60
e		2.28	
e1	4.40		4.60
H		16.10	
L	9.00		9.40
L1	0.80		1.20
L2		0.80	1.00
V1		10°	

Figure 23. IPAK (TO-251) drawing

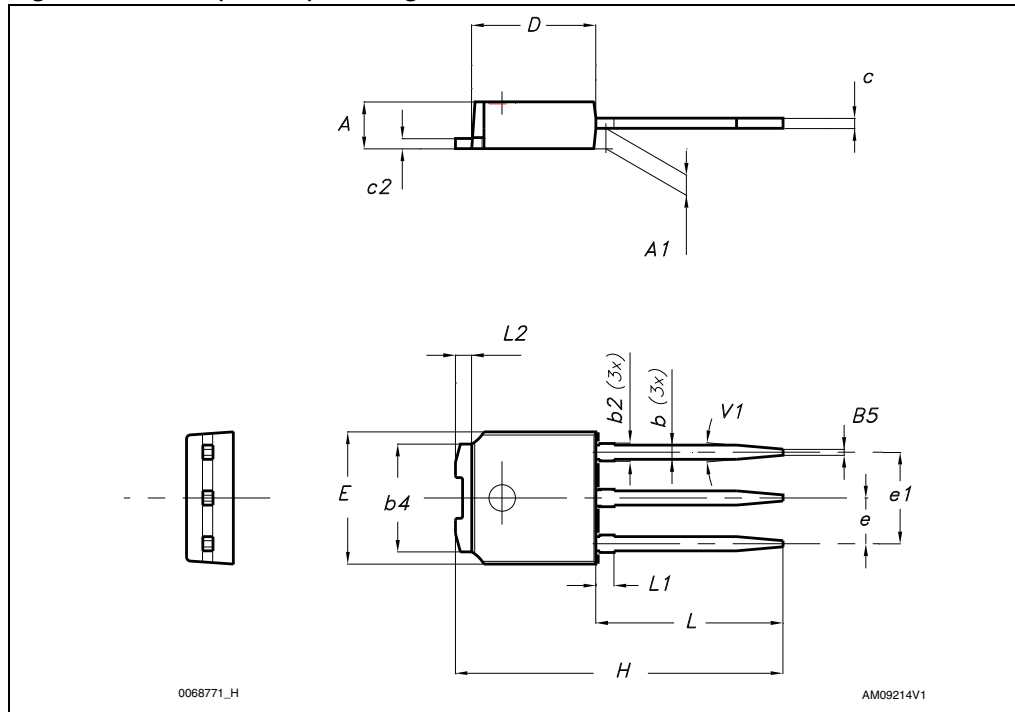
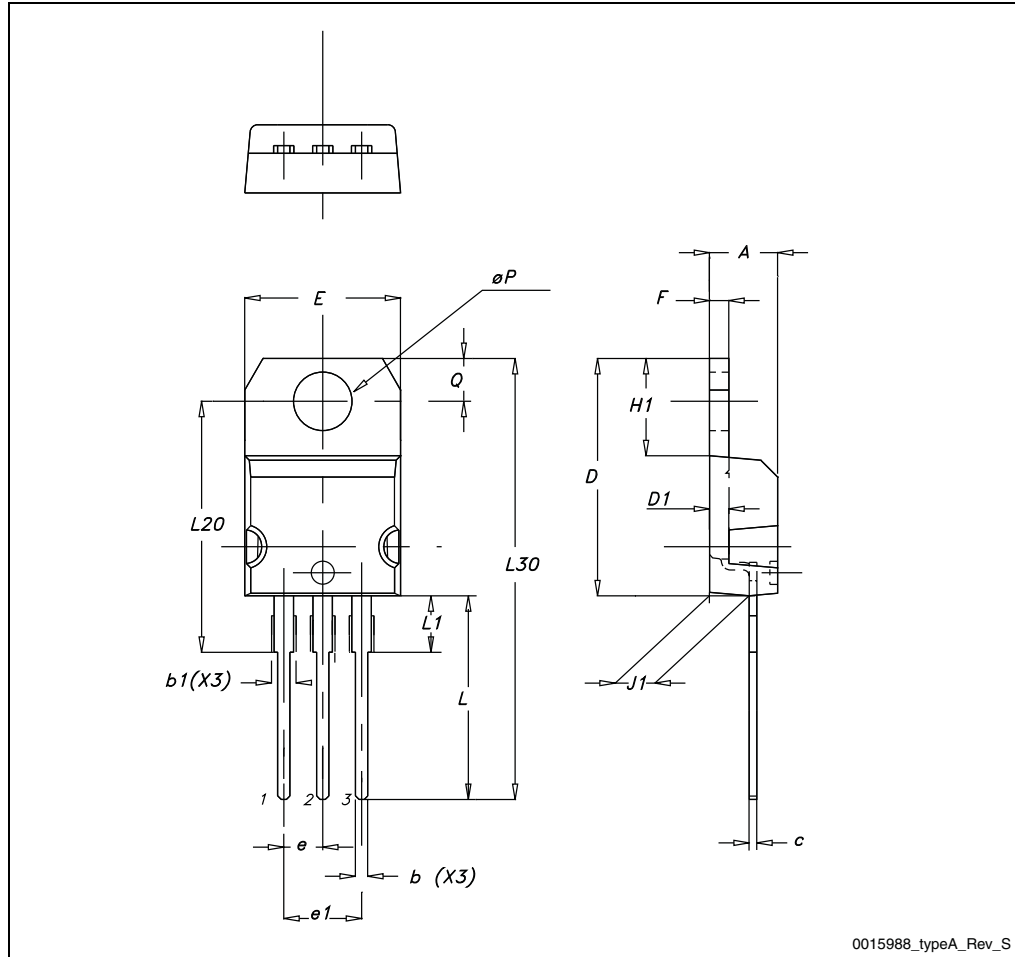

Table 11. TO-220 type A mechanical data

Dim.	mm		
	Min.	Typ.	Max.
A	4.40		4.60
b	0.61		0.88
b1	1.14		1.70
c	0.48		0.70
D	15.25		15.75
D1		1.27	
E	10		10.40
e	2.40		2.70
e1	4.95		5.15
F	1.23		1.32
H1	6.20		6.60
J1	2.40		2.72
L	13		14
L1	3.50		3.93
L20		16.40	
L30		28.90	
ØP	3.75		3.85
Q	2.65		2.95



Figure 24. TO-220 type A drawing



## 5 Packaging mechanical data

Table 12. DPAK (TO-252) tape and reel mechanical data

Tape			Reel		
Dim.	mm		Dim.	mm	
	Min.	Max.		Min.	Max.
A0	6.8	7	A		330
B0	10.4	10.6	B	1.5	
B1		12.1	C	12.8	13.2
D	1.5	1.6	D	20.2	
D1	1.5		G	16.4	18.4
E	1.65	1.85	N	50	
F	7.4	7.6	T		22.4
K0	2.55	2.75			
P0	3.9	4.1		Base qty.	2500
P1	7.9	8.1		Bulk qty.	2500
P2	1.9	2.1			
R	40				
T	0.25	0.35			
W	15.7	16.3			

Figure 25. Tape for DPAK (TO-252)

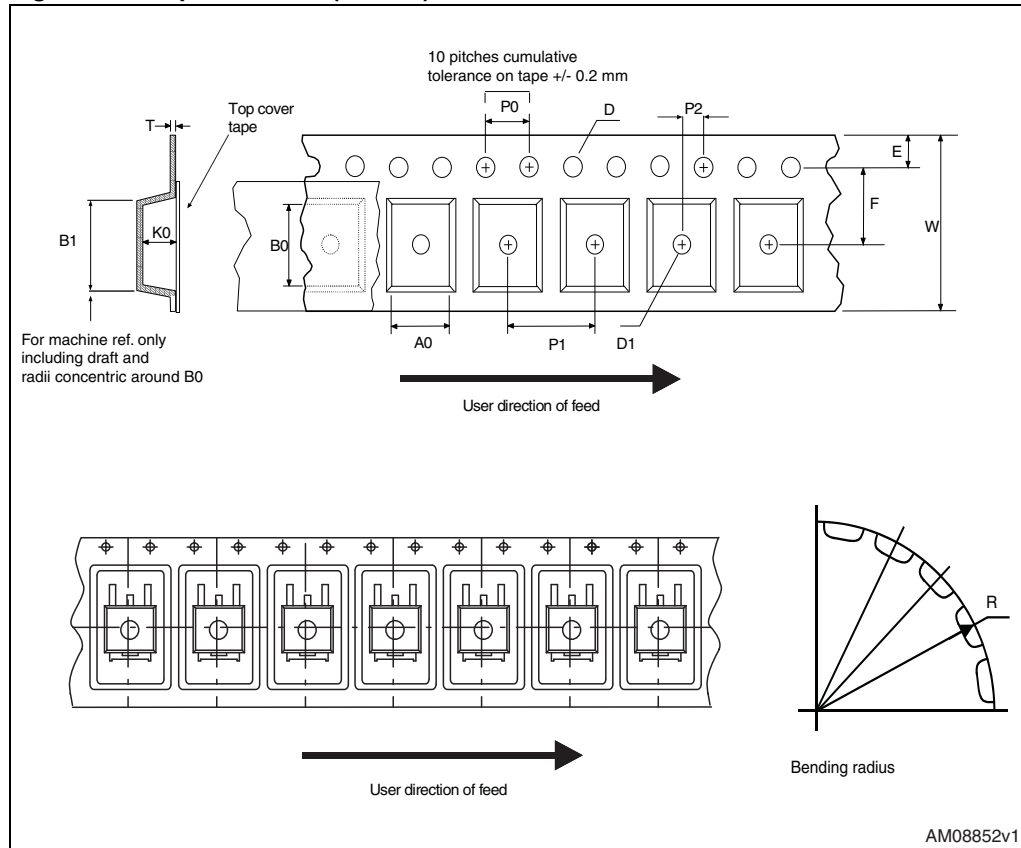
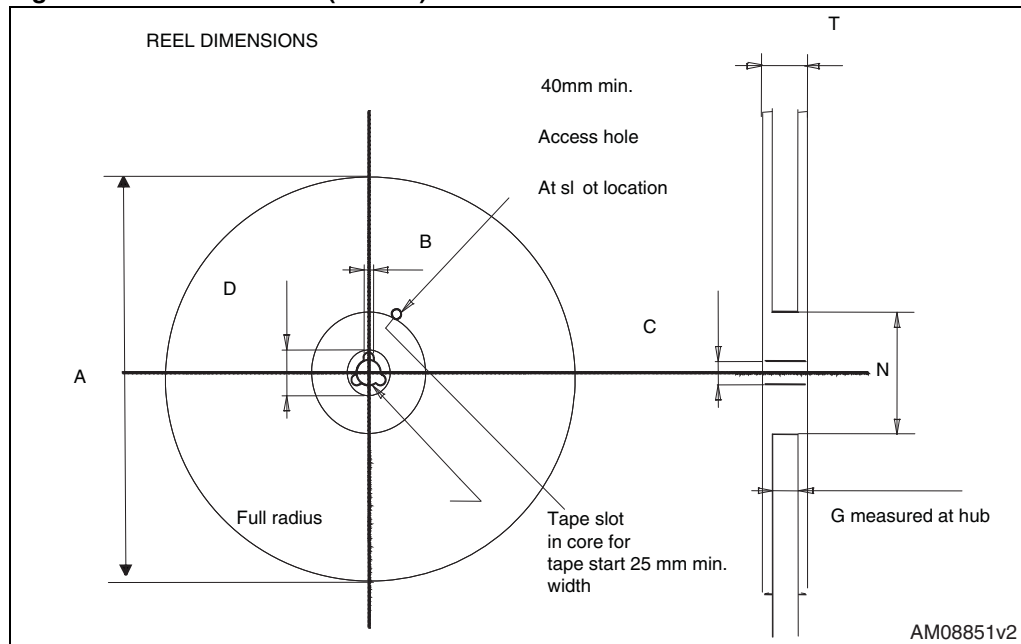

Figure 26. Reel for DPAK (TO-252)



## 6 Revision history

**Table 13. Document revision history**

Date	Revision	Changes
19-Oct-2007	1	First release
23-Sep-2008	2	$V_{GS}$ value has been changed on <a href="#">Table 2</a> and <a href="#">Table 5</a>
20-Apr-2009	3	<ul style="list-style-type: none"><li>– Inserted typical and maximum value in <math>V_{GS(th)}</math> parameter</li><li>– <a href="#">Figure 5: Transfer characteristics</a> has been updated</li><li>– Added device in TO-220</li></ul>
05-Apr-2011	4	<ul style="list-style-type: none"><li>– Added device in Short IPAK</li><li>– Added max values in <a href="#">Table 5: Dynamic</a></li><li>– <math>V_{GS}</math> value has been changed in <a href="#">Table 2</a> and <a href="#">Table 4</a></li></ul>

**Please Read Carefully:**

Information in this document is provided solely in connection with ST products. STMicroelectronics NV and its subsidiaries ("ST") reserve the right to make changes, corrections, modifications or improvements, to this document, and the products and services described herein at any time, without notice.

All ST products are sold pursuant to ST's terms and conditions of sale.

Purchasers are solely responsible for the choice, selection and use of the ST products and services described herein, and ST assumes no liability whatsoever relating to the choice, selection or use of the ST products and services described herein.

No license, express or implied, by estoppel or otherwise, to any intellectual property rights is granted under this document. If any part of this document refers to any third party products or services it shall not be deemed a license grant by ST for the use of such third party products or services, or any intellectual property contained therein or considered as a warranty covering the use in any manner whatsoever of such third party products or services or any intellectual property contained therein.

**UNLESS OTHERWISE SET FORTH IN ST'S TERMS AND CONDITIONS OF SALE ST DISCLAIMS ANY EXPRESS OR IMPLIED WARRANTY WITH RESPECT TO THE USE AND/OR SALE OF ST PRODUCTS INCLUDING WITHOUT LIMITATION IMPLIED WARRANTIES OF MERCHANTABILITY, FITNESS FOR A PARTICULAR PURPOSE (AND THEIR EQUIVALENTS UNDER THE LAWS OF ANY JURISDICTION), OR INFRINGEMENT OF ANY PATENT, COPYRIGHT OR OTHER INTELLECTUAL PROPERTY RIGHT.**

**UNLESS EXPRESSLY APPROVED IN WRITING BY AN AUTHORIZED ST REPRESENTATIVE, ST PRODUCTS ARE NOT RECOMMENDED, AUTHORIZED OR WARRANTED FOR USE IN MILITARY, AIR CRAFT, SPACE, LIFE SAVING, OR LIFE SUSTAINING APPLICATIONS, NOR IN PRODUCTS OR SYSTEMS WHERE FAILURE OR MALFUNCTION MAY RESULT IN PERSONAL INJURY, DEATH, OR SEVERE PROPERTY OR ENVIRONMENTAL DAMAGE. ST PRODUCTS WHICH ARE NOT SPECIFIED AS "AUTOMOTIVE GRADE" MAY ONLY BE USED IN AUTOMOTIVE APPLICATIONS AT USER'S OWN RISK.**

Resale of ST products with provisions different from the statements and/or technical features set forth in this document shall immediately void any warranty granted by ST for the ST product or service described herein and shall not create or extend in any manner whatsoever, any liability of ST.

ST and the ST logo are trademarks or registered trademarks of ST in various countries.

Information in this document supersedes and replaces all information previously supplied.

The ST logo is a registered trademark of STMicroelectronics. All other names are the property of their respective owners.

© 2011 STMicroelectronics - All rights reserved

STMicroelectronics group of companies

Australia - Belgium - Brazil - Canada - China - Czech Republic - Finland - France - Germany - Hong Kong - India - Israel - Italy - Japan - Malaysia - Malta - Morocco - Philippines - Singapore - Spain - Sweden - Switzerland - United Kingdom - United States of America

[www.st.com](http://www.st.com)

