

Dual CoolMOS™ 1) Power MOSFET

Common Source Topology
DCB isoated package

$$\begin{aligned} V_{DSS} &= 600 \text{ V} \\ I_{D25} &= 47 \text{ A} \\ R_{DS(on)max} &= 45 \text{ m}\Omega/\text{MOSFET} \end{aligned}$$

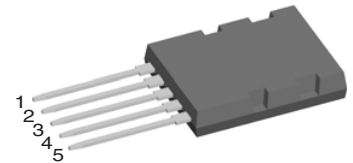
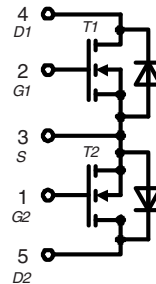

MOSFET T1/T2

Symbol	Conditions	Maximum Ratings	
V_{DSS}	$T_{VJ} = 25^\circ\text{C}$	600	V
V_{D1D2}	$T_{VJ} = 25^\circ\text{C}$	± 600	V
V_{GS}		± 20	V
I_{D25}	$T_C = 25^\circ\text{C}$	47	A
I_{D90}	$T_C = 90^\circ\text{C}$	32	A
E_{AS} E_{AR}	single pulse repetitive } $I_D = 11 \text{ A}; T_C = 25^\circ\text{C}$	1950 3	mJ mJ

Features

- fast CoolMOS™ 1) power MOSFET 4th generation
- High blocking capability
- Lowest resistance
- Avalanche rated for unclamped inductive switching (UIS)
- Low thermal resistance due to reduced chip thickness
- Enhanced total power density

Applications

- AC Switch
 - power regulation of AC heating
 - light dimming
- Power factor correction (PFC) interleaved operation mode
- Push pull converter

Symbol	Conditions	Characteristic Values ($T_{VJ} = 25^\circ\text{C}$, unless otherwise specified)		
		min.	typ.	max.
R_{DSon}	$V_{GS} = 10 \text{ V}; I_D = 44 \text{ A}$		40	45 m Ω
R_{DSon}	total between D1 and D2 $V_{G1S} = V_{G2S} = 10 \text{ V}; I_D = 44 \text{ A}$		80	m Ω
V_{GSth}	$V_{DS} = V_{GS}; I_D = 3 \text{ mA}$	2.5	3	3.5 V
I_{DSS}	$V_{DS} = V_{DSS}; V_{GS} = 0 \text{ V}; T_{VJ} = 25^\circ\text{C}$ $T_{VJ} = 125^\circ\text{C}$		50	10 μA μA
I_{GSS}	$V_{GS} = \pm 20 \text{ V}; V_{DS} = 0 \text{ V}$			100 nA
C_{iss} C_{oss}	} $V_{GS} = 0 \text{ V}; V_{DS} = 100 \text{ V}$ f = 1 MHz		6800 320	pF pF
Q_g Q_{gs} Q_{gd}	} $V_{GS} = 0 \text{ to } 10 \text{ V}; V_{DS} = 400 \text{ V}; I_D = 44 \text{ A}$		150 35 50	nC nC nC
$t_{d(on)}$ t_r $t_{d(off)}$ t_f	} $V_{GS} = 10 \text{ V}; V_{DS} = 400 \text{ V};$ $I_D = 44 \text{ A}; R_G = 3.3 \Omega$		30 20 100 10	ns ns ns ns
R_{thJC} R_{thCH}	with heatsink compound		0.25	0.45 K/W K/W

¹⁾ CoolMOS™ is a trademark of Infineon Technologies AG.

Source-Drain Diode

Characteristic Values

(T_J = 25°C, unless otherwise specified)

		min.	typ.	max.
I _S	V _{GS} = 0 V			44 A
V _{SD}	I _F = 44 A; V _{GS} = 0 V		0.9	1.2 V
t _{rr}	I _F = 44 A; -di/dt = 100 A/μs; V _R = 400 V		600	ns
Q _{RM}			17	μC
I _{RM}			60	A

Component

Symbol	Conditions	Maximum Ratings
T _{VJ}		-55...+150 °C
T _{stg}		-55...+150 °C
V _{ISOL}	I _{ISOL} ≤ 1 mA; 50/60 Hz; t = 1 min	2500 V~
F _C	Mounting force with clip	40 - 180 N

Symbol	Conditions	Characteristic Values		
		min.	typ.	max.
C _P	coupling capacity between shorted pins and mounting tab in the case		50	pF
d _S , d _A	pin - pin	tbd		mm
d _S , d _A	pin - backside metal	tbd		mm
Weight			10	g

ISOPLUS264

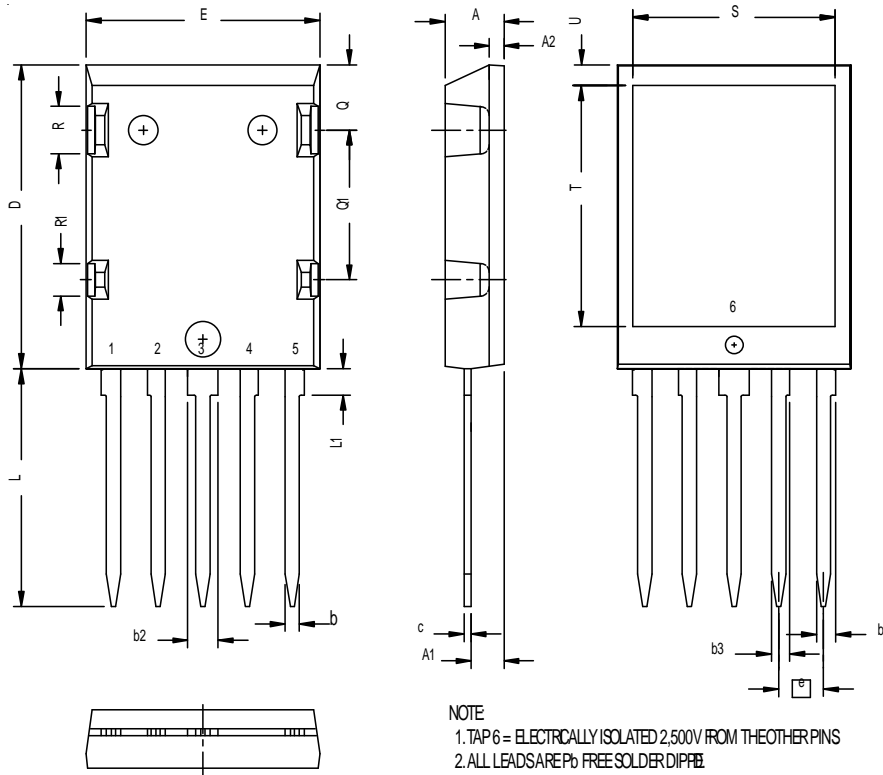

SYM	INCHES		MILLIMETERS	
	MIN	MAX	MIN	MAX
A	.190	.205	4.83	5.21
A1	.102	.118	2.58	3.00
A2	.046	.055	1.17	1.40
b	.045	.055	1.14	1.40
b1	.063	.072	1.60	1.83
b2	.100	.110	2.54	2.78
b3	.058	.088	1.47	1.73
c	.020	.029	0.51	0.74
D	1.020	1.040	25.91	26.42
E	.770	.799	19.58	20.29
e	.150 BSC		3.81 BSC	
L	.780	.820	19.81	20.83
L1	.080	.102	2.03	2.59
Q	.210	.235	5.33	5.97
Q1	.490	.513	12.44	13.03
R	.150	.180	3.81	4.57
R1	.100	.130	2.54	3.30
S	.868	.890	16.97	17.53
T	.801	.821	20.34	20.85
U	.065	.080	1.65	2.03

All curves for single MOSFET T1 or T2 only

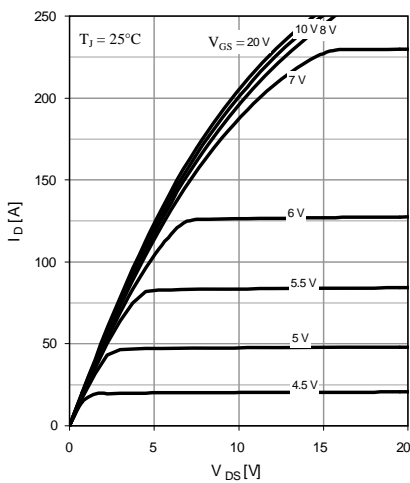

Fig. 1 Typ. output characteristics

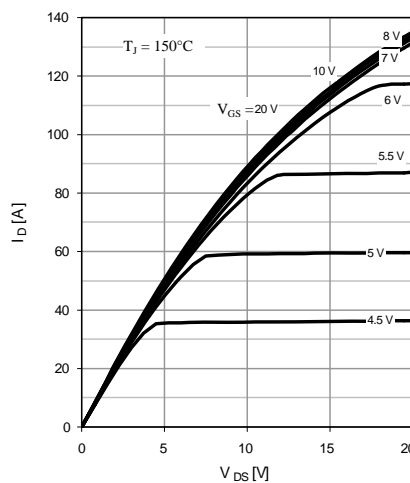

Fig. 2 Typ. output characteristics

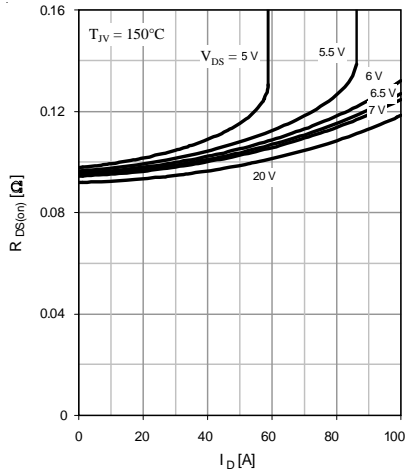

Fig. 3 Typ. drain-source on-state resistance

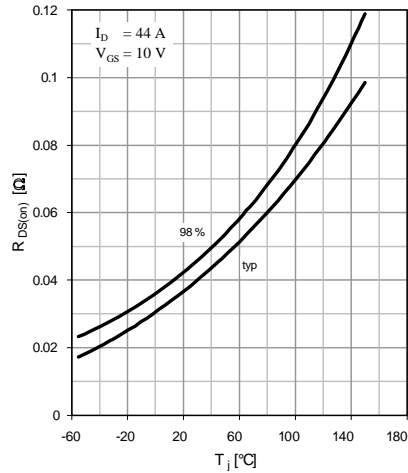

Fig. 4 Drain-source on-state resistance

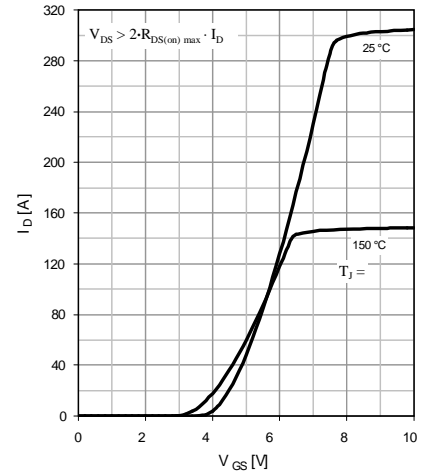

Fig. 5 Typ. transfer characteristics

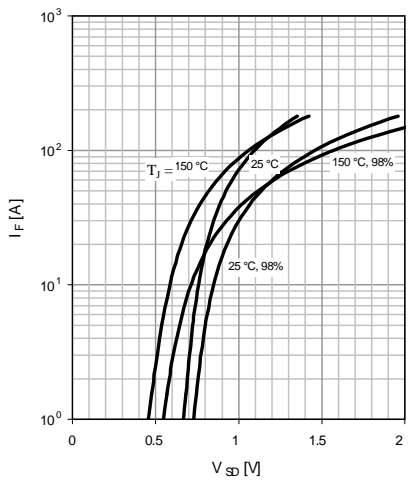

Fig. 6 Forward characteristic of reverse diode

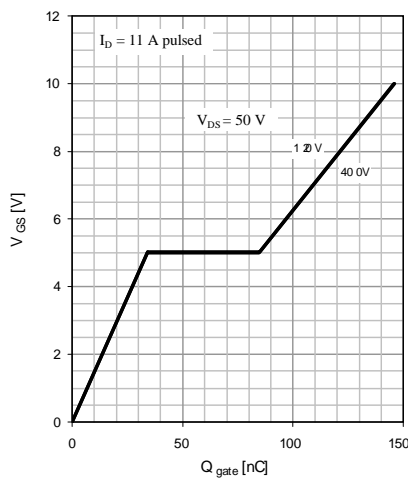

Fig. 7 Typ. gate charge

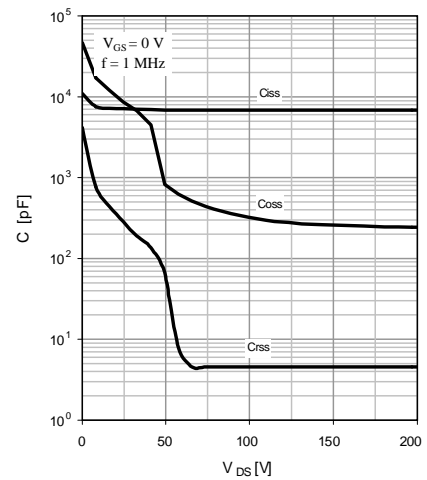

Fig. 8 Typ. capacitances

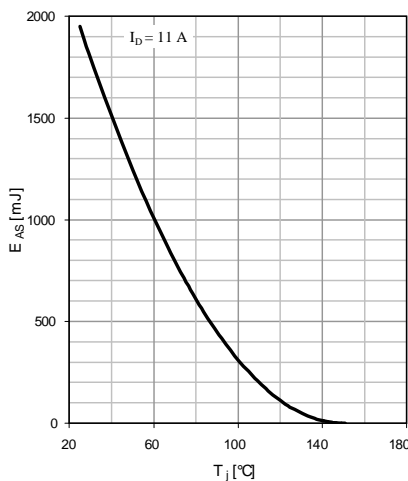

Fig. 9 Avalanche energy

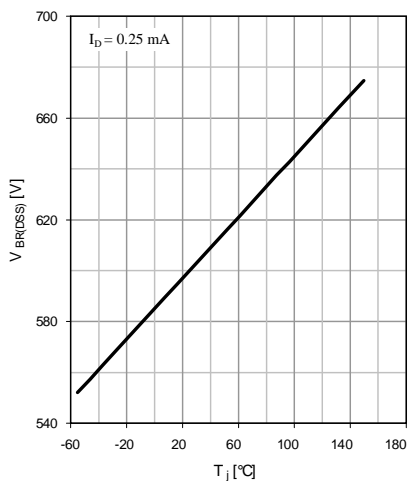

Fig. 10 Drain-source breakdown voltage