

HiPerFAST™ IGBT

C2-Class High Speed

IGBT in ISOPLUS220™ Case

Electrically Isolated Back Surface

IXGC 16N60C2
IXGC 16N60C2D1

$$V_{CES} = 600 \text{ V}$$

$$I_{C25} = 20 \text{ A}$$

$$V_{CE(sat)} = 3.0 \text{ V}$$

$$t_{fi(typ)} = 35 \text{ ns}$$

Preliminary Data Sheet

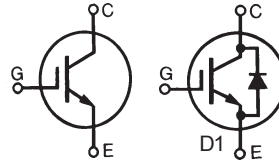

Symbol	Test Conditions	Maximum Ratings	
V_{CES}	$T_J = 25^\circ\text{C}$ to 150°C	600	V
V_{CGR}	$T_J = 25^\circ\text{C}$ to 150°C ; $R_{GE} = 1 \text{ M}\Omega$	600	V
V_{GES}	Continuous	± 20	V
V_{GEM}	Transient	± 30	V
I_{C25}	$T_C = 25^\circ\text{C}$	20	A
I_{C110}	$T_C = 110^\circ\text{C}$	8	A
I_{D110}	$T_C = 110^\circ\text{C}$ (IXGC16N60C2D1 diode)	10	A
I_{CM}	$T_C = 25^\circ\text{C}$, 1 ms	100	A
SSOA (RBSOA)	$V_{GE} = 15 \text{ V}$, $T_J = 125^\circ\text{C}$, $R_G = 22 \Omega$ Clamped inductive load	$I_{CM} = 32$ @ $0.8 V_{CES}$	A
P_c	$T_C = 25^\circ\text{C}$	63	W
T_J		-55 ... +150	$^\circ\text{C}$
T_{JM}		150	$^\circ\text{C}$
T_{stg}		-55 ... +150	$^\circ\text{C}$
F_c	Mounting Force	11..65/2.5..15	N/lb.
V_{ISOL}	Isolation Voltage; 50/60Hz; t = 1minute; RMS	2500	V
	Maximum lead temperature for soldering 1.6 mm (0.062 in.) from case for 10 s	300	$^\circ\text{C}$
Weight		2	g

ISOPLUS 220™ (IXGC)
E153432

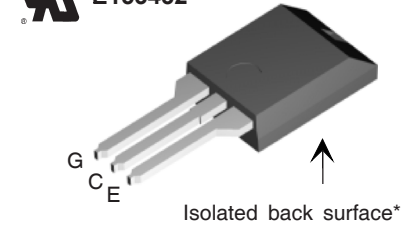

G = Gate C = Collector
E = Emitter

Features

- DCB Isolated mounting tab
- UL recognized (E153432)
- Meets TO-273 package Outline
- High current handling capability
- MOS Gate turn-on
- drive simplicity
- Epoxy meets UL94V-0 flammability classification

Applications

- Uninterruptible power supplies (UPS)
- Switched-mode and resonant-mode power supplies
- AC motor speed control
- DC servo and robot drives
- DC choppers

Advantages

- Easy assembly
- High power density
- Very fast switching speeds for high frequency applications

Symbol	Test Conditions	Characteristic Values ($T_J = 25^\circ\text{C}$, unless otherwise specified)		
		min.	typ.	max.
$V_{GE(th)}$	$I_C = 250 \mu\text{A}$, $V_{CE} = V_{GE}$	2.5		5.0 V
I_{CES}	$V_{CE} = V_{CES}$ $V_{GE} = 0 \text{ V}$			25 μA 50 μA
I_{GES}	$V_{CE} = 0 \text{ V}$, $V_{GE} = \pm 20 \text{ V}$			$\pm 100 \text{ nA}$
$V_{CE(sat)}$	$I_C = 12 \text{ A}$, $V_{GE} = 15 \text{ V}$ Note 2		2.7 2.1	3.0 V V
				$T_J = 125^\circ\text{C}$

Symbol	Test Conditions	Characteristic Values ($T_J = 25^\circ\text{C}$, unless otherwise specified)		
		min.	typ.	max.
g_{fs}	$I_C = 12\text{A}; V_{CE} = 10\text{V}$, Note 2.	8	12	S
C_{ies}	$V_{CE} = 25\text{V}, V_{GE} = 0\text{V}, f = 1\text{MHz}$		720	pF
C_{oes}			55	pF
	16N60C2		65	pF
	16N60C2D1			
C_{res}			19	pF
Q_g	$I_C = 20\text{A}, V_{GE} = 15\text{V}, V_{CE} = 0.5 V_{CES}$		32	nC
Q_{ge}			6	nC
Q_{gc}			10	nC
$t_{d(on)}$	Inductive load, $T_J = 25^\circ\text{C}$		25	ns
t_{ri}	$I_C = 12\text{A}; V_{GE} = 15\text{V}$		15	ns
$t_{d(off)}$	$V_{CE} = 400\text{V}; R_G = R_{off} = 22\ \Omega$		60	120
t_{fi}	Note 1.		35	100
E_{off}			60	100
				μJ
$t_{d(on)}$	Inductive load, $T_J = 125^\circ\text{C}$		25	ns
t_{ri}	$I_C = 12\text{A}; V_{GE} = 15\text{V}$		18	ns
E_{on}	$V_{CE} = 400\text{V}; R_G = R_{off} = 22\ \Omega$	16N60C2D1	0.38	mJ
$t_{d(off)}$	Note 1		115	ns
t_{fi}			70	ns
E_{off}			150	μJ
R_{thJC}				2.0 K/W
R_{thCK}			0.25	K/W

ISOPLUS220 Outline

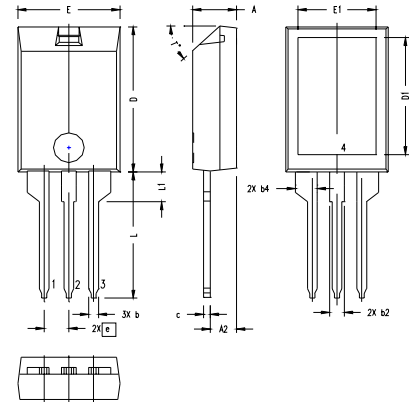

SYM	INCHES		MILLIMETERS	
	MIN	MAX	MIN	MAX
A	.157	.197	4.00	5.00
A2	.098	.118	2.50	3.00
b	.035	.051	0.90	1.30
b2	.049	.065	1.25	1.65
b4	.093	.100	2.35	2.55
c	.028	.039	0.70	1.00
D	.591	.630	15.00	16.00
D1	.472	.512	12.00	13.00
E	.394	.433	10.00	11.00
E1	.295	.335	7.50	8.50
e	.100 BASIC		2.55 BASIC	
L	.512	.571	13.00	14.50
L1	.118	.138	3.00	3.50
T*			42.5°	47.5°

NOTE:
1. Bottom heatsink (Pin 4) is electrically isolated from Pin 1, 2, or 3.
2. This drawing will meet dimensional requirement of JEDEC SS Product Outline 10-273 except D and D1 dimension.

Symbol	Test Conditions	Characteristic Values ($T_J = 25^\circ\text{C}$, unless otherwise specified)		
		min.	typ.	max.
V_F	$I_F = 10\text{A}, V_{GE} = 0\text{V}$ $T_J = 125^\circ\text{C}$			2.66 V 1.66 V
I_{RM}	$I_F = 12\text{A}; -di_F/dt = 100\text{A}/\mu\text{s}, V_R = 100\text{V}$		2.5	A
t_{rr}	$V_{GE} = 0\text{V}; T_J = 125^\circ\text{C}$		110	ns
t_{rr}	$I_F = 1\text{A}; -di_F/dt = 100\text{A}/\mu\text{s}; V_R = 30\text{V}, V_{GE} = 0\text{V}$		30	ns
R_{thJC}				2.5 K/W

- Notes:
- Switching times may increase for $V_{CE}(\text{Clamp}) > 0.8 \cdot V_{CES}$, higher T_J , or increased R_G .
 - Pulse test, $t \leq 300\ \mu\text{s}$, duty cycle $d \leq 2\%$

IXYS reserves the right to change limits, test conditions, and dimensions.

IXYS MOSFETs and IGBTs are covered by one or more of the following U.S. patents:	4,835,592	4,931,844	5,049,961	5,237,481	6,162,665	6,404,065 B1	6,683,344	6,727,585
	4,850,072	5,017,508	5,063,307	5,381,025	6,259,123 B1	6,534,343	6,710,405 B2	6,759,692
	4,881,106	5,034,796	5,187,117	5,486,715	6,306,728 B1	6,583,505	6,710,463	