

**HiPerFAST™ IGBT**  
**B2-Class High Speed**  
**IGBT in ISOPLUS220™ Case**  
**Electrically Isolated Back Surface**

**IXGC 16N60B2**  
**IXGC 16N60B2D1**

$V_{CES} = 600 \text{ V}$   
 $I_{C25} = 28 \text{ A}$   
 $V_{CE(sat)} = 2.3 \text{ V}$   
 $t_{fi(typ)} = 80 \text{ ns}$

Preliminary Data Sheet

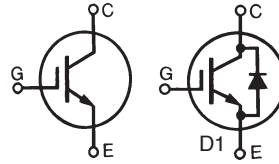

Symbol	Test Conditions	Maximum Ratings	
$V_{CES}$	$T_J = 25^\circ\text{C to } 150^\circ\text{C}$	600	V
$V_{CGR}$	$T_J = 25^\circ\text{C to } 150^\circ\text{C}; R_{GE} = 1 \text{ M}\Omega$	600	V
$V_{GES}$	Continuous	$\pm 20$	V
$V_{GEM}$	Transient	$\pm 30$	V
$I_{C25}$	$T_C = 25^\circ\text{C}$	28	A
$I_{C110}$	$T_C = 110^\circ\text{C}$	13	A
$I_{D110}$	$T_C = 110^\circ\text{C}$ (IXGC16N60B2D1 diode)	10	A
$I_{CM}$	$T_C = 25^\circ\text{C}, 1 \text{ ms}$	100	A
<b>SSOA (RBSOA)</b>	$V_{GE} = 15 \text{ V}, T_J = 125^\circ\text{C}, R_G = 22 \Omega$ Clamped inductive load	$I_{CM} = 32$ @ $0.8 V_{CES}$	A
$P_C$	$T_C = 25^\circ\text{C}$	63	W
$T_J$		-55 ... +150	$^\circ\text{C}$
$T_{JM}$		150	$^\circ\text{C}$
$T_{stg}$		-55 ... +150	$^\circ\text{C}$
$F_C$	Mounting Force	11..65/2.5..15	N/lb.
$V_{ISOL}$	Isolation Voltage; 50/60Hz; $t = 1 \text{ minute}; \text{RMS}$	2500	V
	Maximum lead temperature for soldering 1.6 mm (0.062 in.) from case for 10 s	300	$^\circ\text{C}$
<b>Weight</b>		2	g

**ISOPLUS 220™ (IXGC)**  
**E153432**

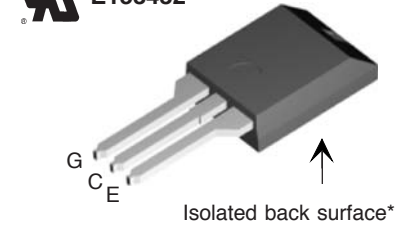

G = Gate      C = Collector  
E = Emitter

**Features**

- DCB Isolated mounting tab
- UL recognized (E153432)
- Meets TO-273 package Outline
- High current handling capability
- MOS Gate turn-on  
- drive simplicity
- Epoxy meets UL94V-0 flammability classification

**Applications**

- Uninterruptible power supplies (UPS)
- Switched-mode and resonant-mode power supplies
- AC motor speed control
- DC servo and robot drives
- DC choppers

**Advantages**

- Easy assembly
- High power density
- Very fast switching speeds for high frequency applications

Symbol	Test Conditions	Characteristic Values ( $T_J = 25^\circ\text{C}$ , unless otherwise specified)		
		min.	typ.	max.
$V_{GE(th)}$	$I_C = 250 \mu\text{A}, V_{CE} = V_{GE}$	2.5		5.0 V
$I_{CES}$	$V_{CE} = V_{CES}$ $V_{GE} = 0 \text{ V}$			25 $\mu\text{A}$ 50 $\mu\text{A}$
$I_{GES}$	$V_{CE} = 0 \text{ V}, V_{GE} = \pm 20 \text{ V}$			$\pm 100 \text{ nA}$
$V_{CE(sat)}$	$I_C = 12 \text{ A}, V_{GE} = 15 \text{ V}$ Note 2		1.8	2.3 V V

Symbol	Test Conditions	Characteristic Values ( $T_J = 25^\circ\text{C}$ , unless otherwise specified)		
		min.	typ.	max.
$g_{fs}$	$I_C = 12\text{A}; V_{CE} = 10\text{V}$ , Note 2.	8	12	S
$C_{ies}$	$V_{CE} = 25\text{V}; V_{GE} = 0\text{V}; f = 1\text{MHz}$		780	pF
$C_{oes}$			55	pF
	16N60B2		65	pF
$C_{res}$			19	pF
$Q_g$	$I_C = 20\text{A}; V_{GE} = 15\text{V}; V_{CE} = 0.5 V_{CES}$		32	nC
$Q_{ge}$			6	nC
$Q_{gc}$			10	nC
$t_{d(on)}$	<b>Inductive load, <math>T_J = 125^\circ\text{C}</math></b>		25	ns
$t_{ri}$	$I_C = 12\text{A}; V_{GE} = 15\text{V}$		15	ns
$t_{d(off)}$	$V_{CE} = 400\text{V}; R_G = R_{off} = 22\ \Omega$		70	150 ns
$t_{fi}$	Note 1		80	150 ns
$E_{off}$			150	260 mJ
$t_{d(on)}$	<b>Inductive load, <math>T_J = 125^\circ\text{C}</math></b>		25	ns
$t_{ri}$	$I_C = 12\text{A}; V_{GE} = 15\text{V}$		18	ns
$E_{on}$	$I_C = 12\text{A}; V_{GE} = 15\text{V}$	16N60B2	0.38	mJ
	$V_{CE} = 400\text{V}; R_G = R_{off} = 22\ \Omega$	16N60B2D1	0.8	mJ
$t_{d(off)}$	Note 1		110	ns
$t_{fi}$			170	ns
$E_{off}$			350	mJ
$R_{thJC}$				2.0 K/W
$R_{thCK}$			0.25	K/W

**ISOPLUS220 Outline**

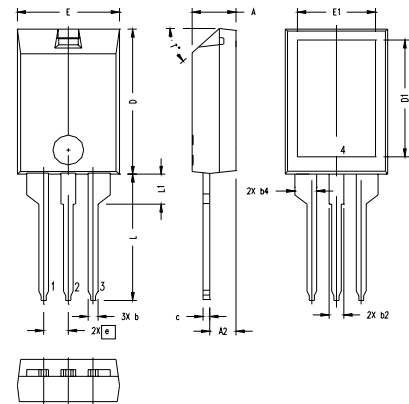

SYM	INCHES		MILLIMETERS	
	MIN	MAX	MIN	MAX
A	.157	.197	4.00	5.00
A2	.098	.118	2.50	3.00
b	.035	.051	0.90	1.30
b2	.049	.065	1.25	1.65
b4	.093	.100	2.35	2.55
c	.028	.039	0.70	1.00
D	.591	.630	15.00	16.00
D1	.472	.512	12.00	13.00
E	.394	.433	10.00	11.00
E1	.295	.335	7.50	8.50
e	.100 BASIC		2.55 BASIC	
L	.512	.571	13.00	14.50
L1	.118	.138	3.00	3.50
T*			42.5°	47.5°

NOTE:  
1. Bottom heatsink (Pin 4) is electrically isolated from Pin 1, 2, or 3.  
2. This drawing will meet dimensional requirement of JEDEC SS Product Outline TO-273 except D and D1 dimension.

Symbol	Test Conditions	Characteristic Values ( $T_J = 25^\circ\text{C}$ , unless otherwise specified)		
		min.	typ.	max.
$V_F$	$I_F = 10\text{A}; V_{GE} = 0\text{V}$			2.66 V
	$T_J = 125^\circ\text{C}$			1.66 V
$I_{RM}$	$I_F = 12\text{A}; -di_F/dt = 100\text{A}/\mu\text{s}; V_R = 100\text{V}$		2.5	A
$t_{rr}$	$V_{GE} = 0\text{V}; T_J = 125^\circ\text{C}$		110	ns
$t_{rr}$	$I_F = 1\text{A}; -di_F/dt = 100\text{A}/\mu\text{s}; V_R = 30\text{V}; V_{GE} = 0\text{V}$		30	ns
$R_{thJC}$				2.5 K/W

Notes: 1. Switching times may increase for  $V_{CE}(\text{Clamp}) > 0.8 \cdot V_{CES}$ , higher  $T_J$ , or increased  $R_G$ .  
2. Pulse test,  $t < 300\text{ms}$ , duty cycle  $d < 2\%$

IXYS reserves the right to change limits, test conditions, and dimensions.

IXYS MOSFETs and IGBTs are covered by	4,835,592	4,931,844	5,049,961	5,237,481	6,162,665	6,404,065 B1	6,683,344	6,727,585
one or more of the following U.S. patents:	4,850,072	5,017,508	5,063,307	5,381,025	6,259,123 B1	6,534,343	6,710,405B2	
	4,881,106	5,034,796	5,187,117	5,486,715	6,306,728 B1	6,583,505	6,710,463	