

E_{AS} 450 mJ, 345 V, internally clamped IGBT

Features

- Low threshold voltage
- Low on-voltage drop
- High voltage clamping feature
- Gate and gate-emitter integrated resistors

Application

- Automotive ignition

Description

This application specific IGBT utilizes the most advanced PowerMESH™ technology. The built-in Zener diodes between gate-collector and gate-emitter provide overvoltage protection capabilities. The device also exhibits low on-state voltage drop and low threshold drive for use in automotive ignition system.

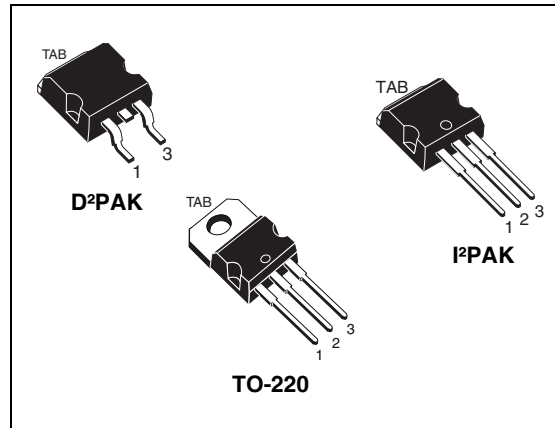

Figure 1. Internal schematic diagram

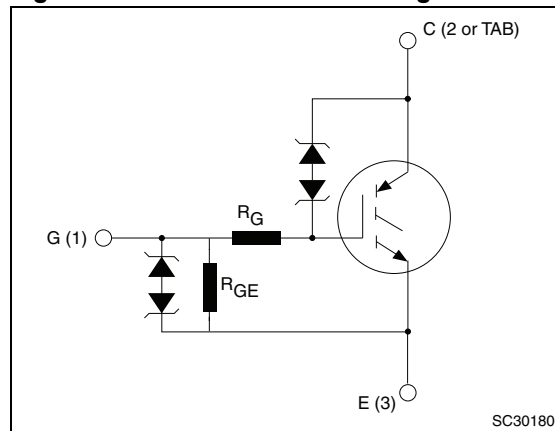

Table 1. Device summary

Order codes	Marking	Package	Packaging
STGB35N35LZ-1	GB35N35LZ	I ² PAK	Tube
STGB35N35LZT4	GB35N35LZ	D ² PAK	Tape and reel
STGP35N35LZ	GP35N35LZ	TO-220	Tube

Contents

1	Electrical ratings	3
2	Electrical characteristics	4
	2.1 Electrical characteristics (curves)	6
3	Test circuits	9
4	Package mechanical data	10
5	Packaging mechanical data	15
6	Revision history	16

1 Electrical ratings

Table 2. Absolute maximum ratings

Symbol	Parameter	Value	Unit
V_{CES}	Collector-emitter voltage ($V_{GE} = 0$)	$V_{CES (clamped)}$	V
V_{ECS}	Emitter collector voltage ($V_{GE} = 0$)	20	V
$I_C^{(1)}$	Continuous collector current at $T_C = 25\text{ °C}$	40	A
$I_C^{(1)}$	Continuous collector current at $T_C = 100\text{ °C}$	30	A
$I_{CP}^{(2)}$	Pulsed collector current	80	A
V_{GE}	Gate-emitter voltage	$V_{GE (clamped)}$	V
P_{TOT}	Total dissipation at $T_C = 25\text{ °C}$	176	W
E_{AS}	Single pulse energy ($T_C=25\text{ °C}$, $L=1.6\text{ mH}$, $I_C = 22\text{ A}$, $V_{CC} = 50\text{ V}$)	450	mJ
ESD	Human body model ($R=1,5\text{ k}\Omega$, $C=100\text{ pF}$)	8	kV
	Machine model ($R=0$, $C=100\text{ pF}$)	800	V
	Charged device model	2	kV
T_{stg}	Storage temperature	- 55 to 175	°C
T_j	Operating junction temperature		

1. Calculated according to the iterative formula:

$$I_C(T_C) = \frac{T_{j(max)} - T_C}{R_{thj-c} \times V_{CE(sat)(max)}(T_{j(max)}, I_C(T_C))}$$

2. Pulse width limited by maximum junction temperature

Table 3. Thermal data

Symbol	Parameter	Value	Unit
$R_{thj-case}$	Thermal resistance junction-case	0.85	°C/W
$R_{thj-amb}$	Thermal resistance junction-ambient	62.5	°C/W

2 Electrical characteristics

($T_j = 25\text{ °C}$ unless otherwise specified)

Table 4. Static

Symbol	Parameter	Test conditions	Min.	Typ.	Max.	Unit
$V_{CES(\text{clamped})}$	Collector emitter clamped voltage ($V_{GE}=0$)	$I_C=2\text{ mA}$, $T_j = -40\text{ °C to }150\text{ °C}$	320	345	380	V
$V_{(BR)ECS}$	Emitter collector break-down voltage ($V_{GE}=0$)	$I_C = 75\text{ mA}$	20	28		V
$V_{GE(\text{clamped})}$	Gate emitter clamped voltage	$I_G = \pm 2\text{ mA}$	12	14	16	V
I_{CES}	Collector cut-off current ($V_{GE} = 0$)	$V_{CE} = 15\text{ V}$, $T_j = 150\text{ °C}$			10	μA
		$V_{CE} = 200\text{ V}$, $T_j = 150\text{ °C}$			100	μA
I_{GES}	Gate-emitter leakage current ($V_{CE} = 0$)	$V_{GE} = \pm 10\text{ V}$	500	625	830	μA
R_{GE}	Gate emitter resistance		12	15	20	k Ω
R_G	Gate resistance			1.5		k Ω
$V_{GE(\text{th})}$	Gate threshold voltage	$V_{CE} = V_{GE}$, $I_C = 1\text{ mA}$, $T_j = -40\text{ °C}$	1.4			V
		$V_{CE} = V_{GE}$, $I_C = 1\text{ mA}$	1.2	1.6	2.3	V
		$V_{CE} = V_{GE}$, $I_C = 1\text{ mA}$, $T_j = 150\text{ °C}$	0.7			V
$V_{CE(\text{sat})}$	Collector-emitter saturation voltage	$V_{GE} = 4.5\text{ V}$, $I_C = 10\text{ A}$		1.15	1.5	V
		$V_{GE} = 4.5\text{ V}$, $I_C = 15\text{ A}$		1.3	1.7	V

Table 5. Dynamic

Symbol	Parameter	Test conditions	Min.	Typ.	Max.	Unit
C_{ies}	Input capacitance	$V_{CE} = 25\text{ V}$, $f = 1\text{ MHz}$, $V_{GE} = 0$	-	700	-	pF
C_{oes}	Output capacitance		-	150	-	pF
C_{res}	Reverse transfer capacitance		-	6	-	pF

Table 6. Functional characteristics

Symbol	Parameter	Test conditions	Min.	Typ.	Max.	Unit
U.I.S.	Functional test open secondary coil	$R_G = 0$, $T_j = 150\text{ °C}$, $V_{CC} = 50\text{ V}$, $V_{GE} = 5\text{ V}$, $L = 1.6\text{ mH}$	18	-	-	A

Table 7. Switching time

Symbol	Parameter	Test conditions	Min.	Typ.	Max.	Unit	
$t_{d(on)}$ t_r	Resistive load Turn-on delay time	$V_{CC} = 14\text{ V}$, $R_L = 1\ \Omega$, $V_{GE} = 5\text{ V}$	-	1.1	-	μs	
	Rise time					7	μs
$t_{d(on)}$ t_r	Resistive load Turn-on delay time	$V_{CC} = 14\text{ V}$, $R_L = 1\ \Omega$, $V_{GE} = 5\text{ V}$ $T_j = 150\text{ °C}$	-	1	-	μs	
	Rise time					6.6	μs
$t_{d(off)}$ t_f dv/dt	Inductive load Turn-off delay time	$V_{CC} = 300\text{ V}$, $L = 1\text{ mH}$ $I_C = 15\text{ A}$, $V_{GE} = 5\text{ V}$	-	26.5	-	μs	
	Fall time					5.5	μs
	Turn-off voltage slope					70	V/ μs
$t_{d(off)}$ t_f dv/dt	Inductive load Turn-off delay time	$V_{CC} = 300\text{ V}$, $L = 1\text{ mH}$ $I_C = 15\text{ A}$, $V_{GE} = 5\text{ V}$ $T_j = 150\text{ °C}$	-	28	-	μs	
	Fall time					9	μs
	Turn-off voltage slope					65	V/ μs

2.1 Electrical characteristics (curves)

Figure 2. Collector-emitter saturation voltage vs temperature **Figure 3. Self clamped inductive switch**

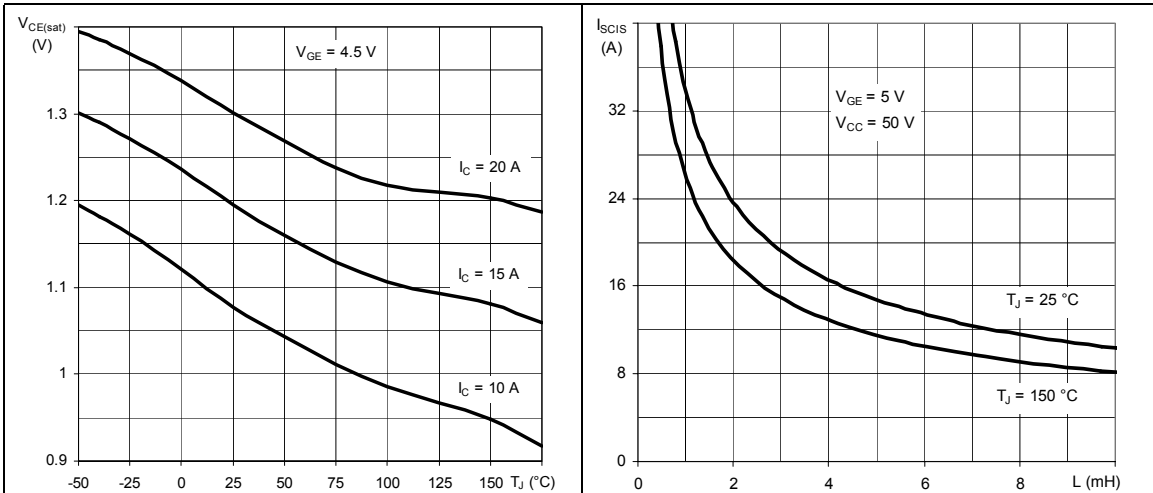

Figure 4. Output characteristics ($T_J = 25^\circ\text{C}$) **Figure 5. Output characteristics ($T_J = -40^\circ\text{C}$)**

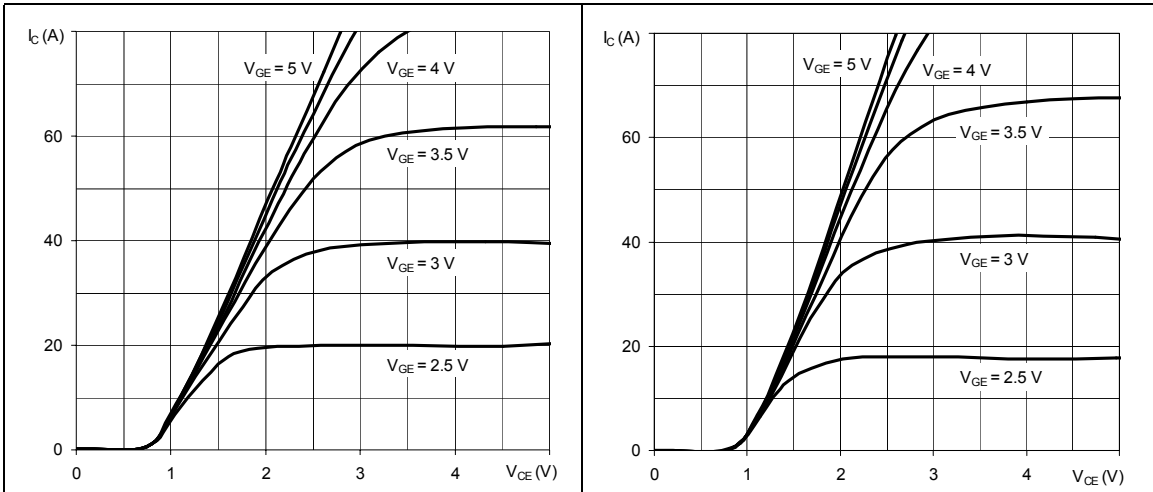

Figure 6. Output characteristics ($T_J = 175\text{ }^\circ\text{C}$) Figure 7. Transfer characteristics

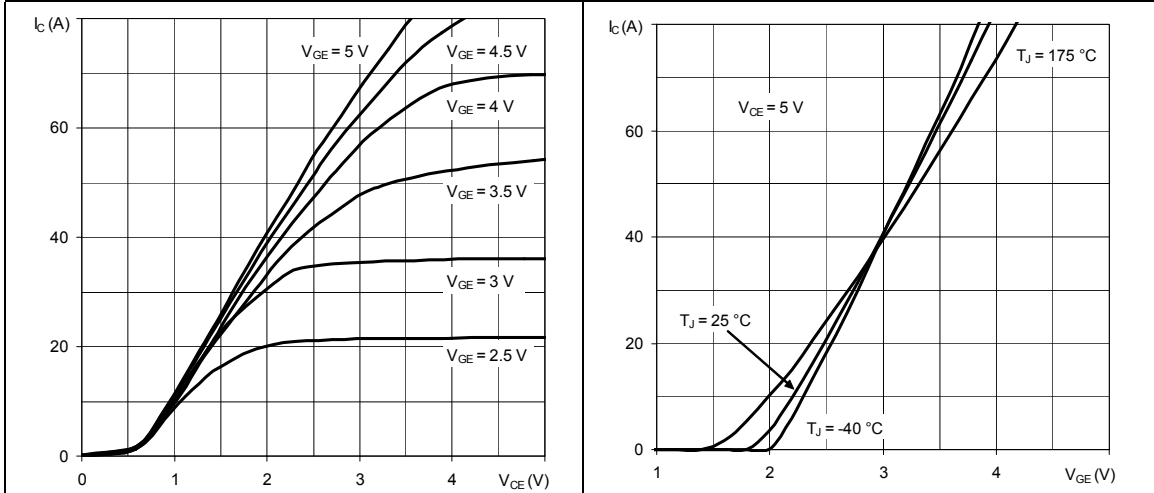

Figure 8. Collector cut-off current vs temperature

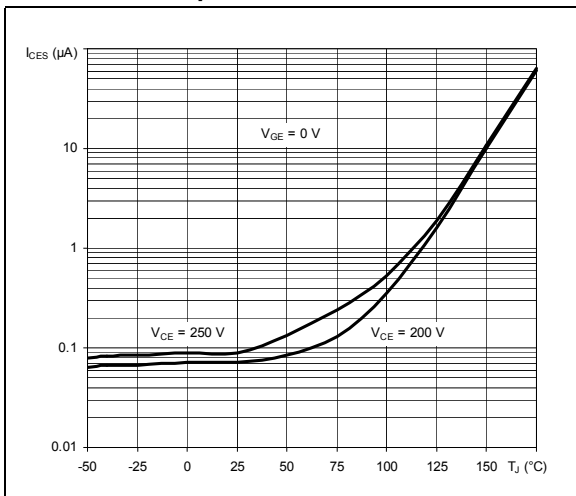

Figure 9. Normalized collector emitter voltage vs temperature

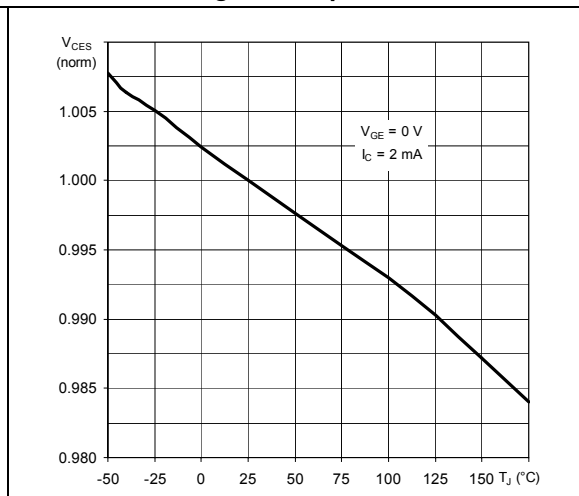

Figure 10. Normalized gate threshold voltage vs temperature Figure 11. Gate charge

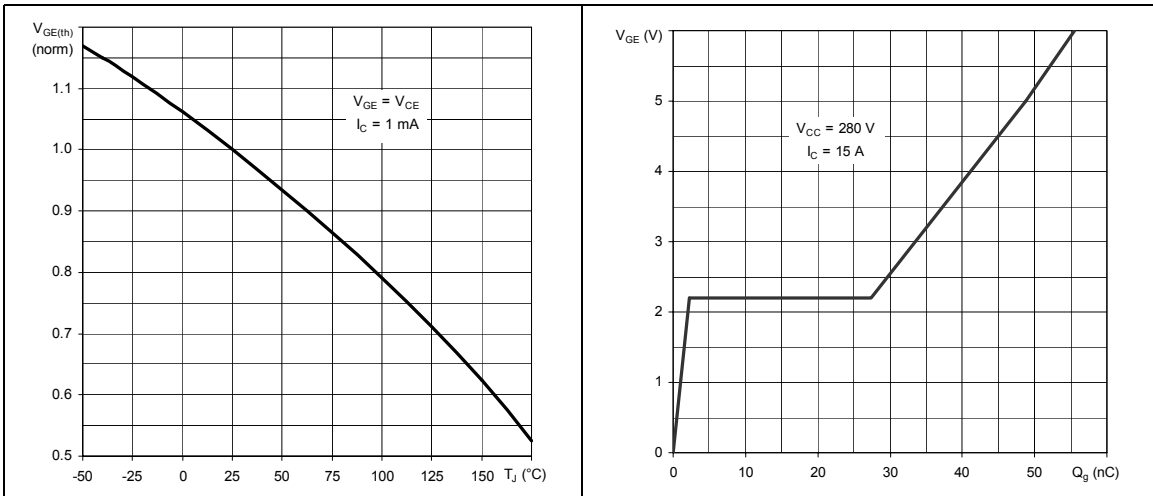
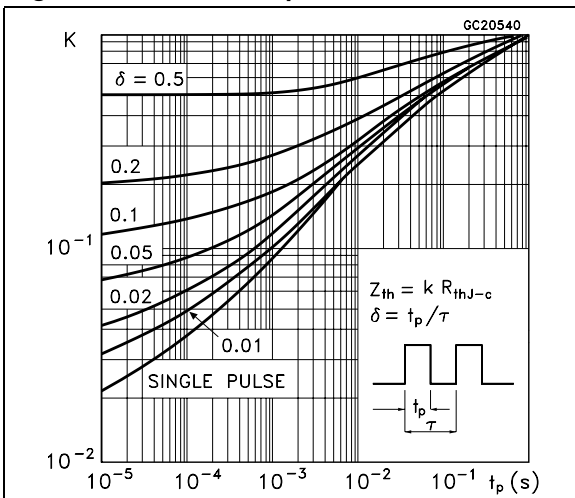

Figure 12. Thermal impedance



4 Package mechanical data

In order to meet environmental requirements, ST offers these devices in different grades of ECOPACK[®] packages, depending on their level of environmental compliance. ECOPACK[®] specifications, grade definitions and product status are available at: www.st.com. ECOPACK is an ST trademark.

Table 8. D²PAK mechanical data

Dim.	mm		
	Min.	Typ.	Max.
A	4.40		4.60
A1	0.03		0.23
b	0.70		0.93
b2	1.14		1.70
c	0.45		0.60
c2	1.23		1.36
D	8.95		9.35
D1	7.50		
E	10		10.40
E1	8.50		
e		2.54	
e1	4.88		5.28
H	15		15.85
J1	2.49		2.69
L	2.29		2.79
L1	1.27		1.40
L2	1.30		1.75
R		0.4	
V2	0°		8°

Figure 16. D²PAK mechanical data drawing

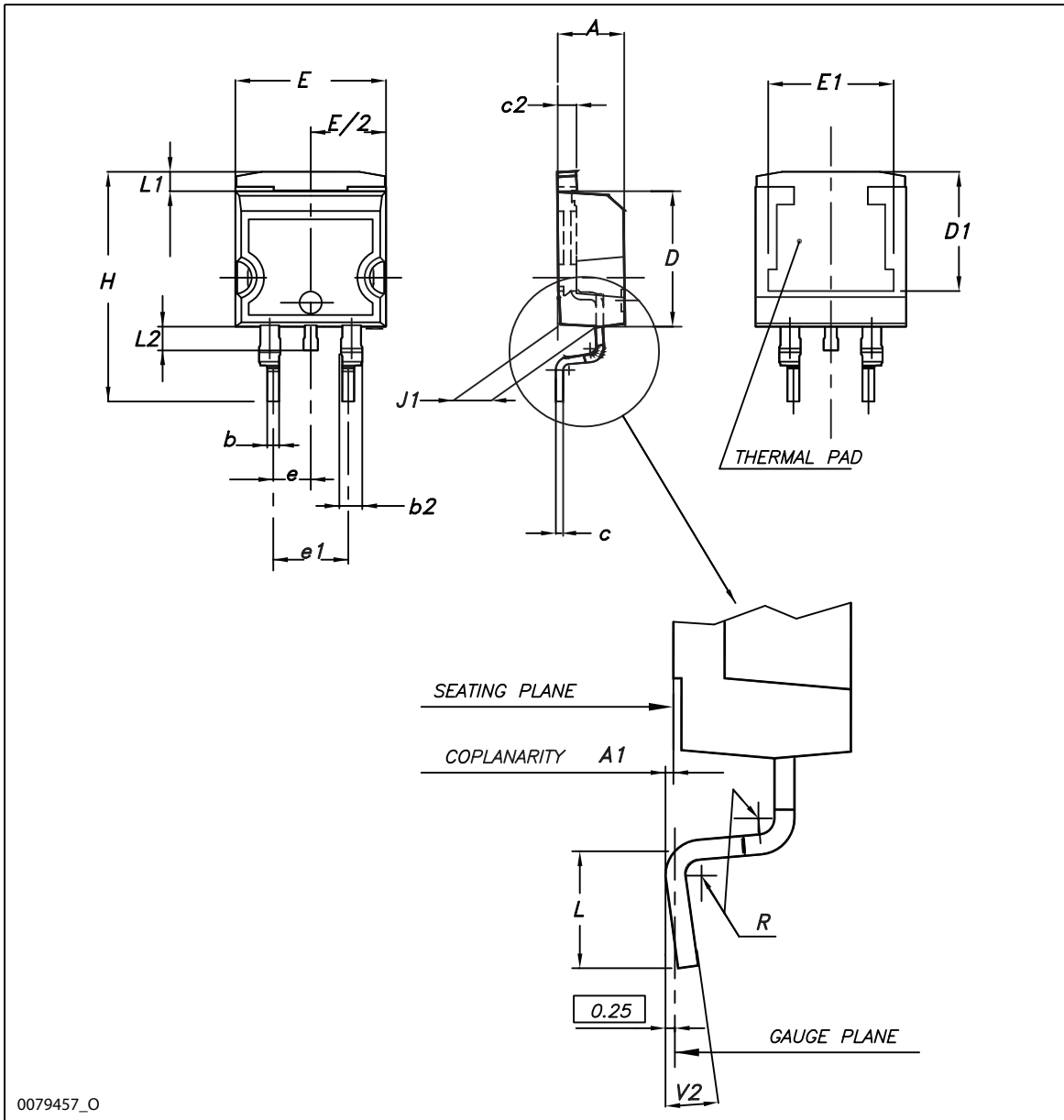

I²PAK (TO-262) mechanical data

Dim	mm			inch		
	Min	Typ	Max	Min	Typ	Max
A	4.40		4.60	0.173		0.181
A1	2.40		2.72	0.094		0.107
b	0.61		0.88	0.024		0.034
b1	1.14		1.70	0.044		0.066
c	0.49		0.70	0.019		0.027
c2	1.23		1.32	0.048		0.052
D	8.95		9.35	0.352		0.368
e	2.40		2.70	0.094		0.106
e1	4.95		5.15	0.194		0.202
E	10		10.40	0.393		0.410
L	13		14	0.511		0.551
L1	3.50		3.93	0.137		0.154
L2	1.27		1.40	0.050		0.055

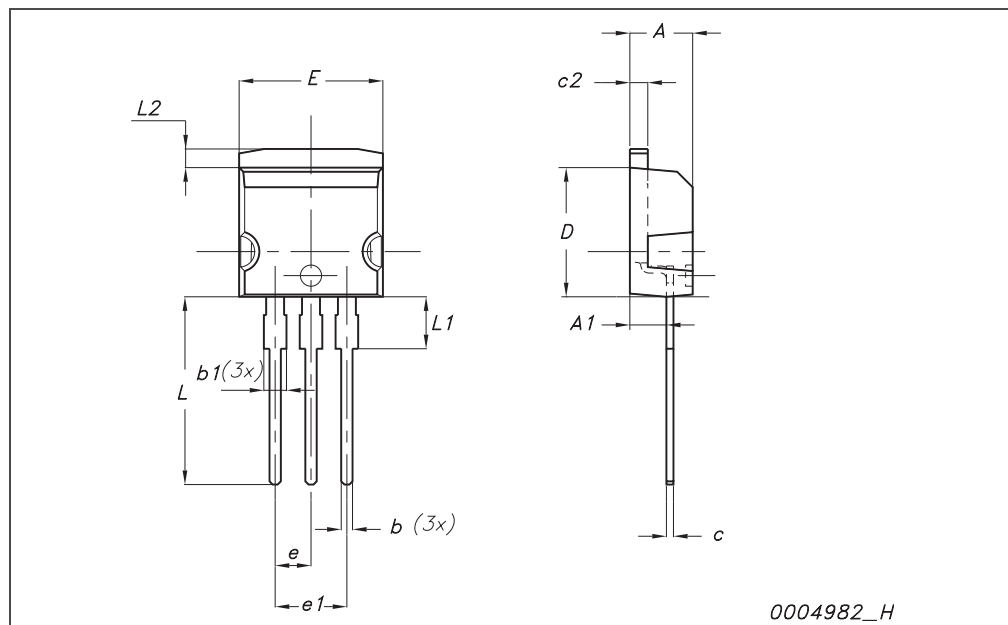

TO-220 type A mechanical data

Dim	mm		
	Min	Typ	Max
A	4.40		4.60
b	0.61		0.88
b1	1.14		1.70
c	0.48		0.70
D	15.25		15.75
D1		1.27	
E	10		10.40
e	2.40		2.70
e1	4.95		5.15
F	1.23		1.32
H1	6.20		6.60
J1	2.40		2.72
L	13		14
L1	3.50		3.93
L20		16.40	
L30		28.90	
∅P	3.75		3.85
Q	2.65		2.95

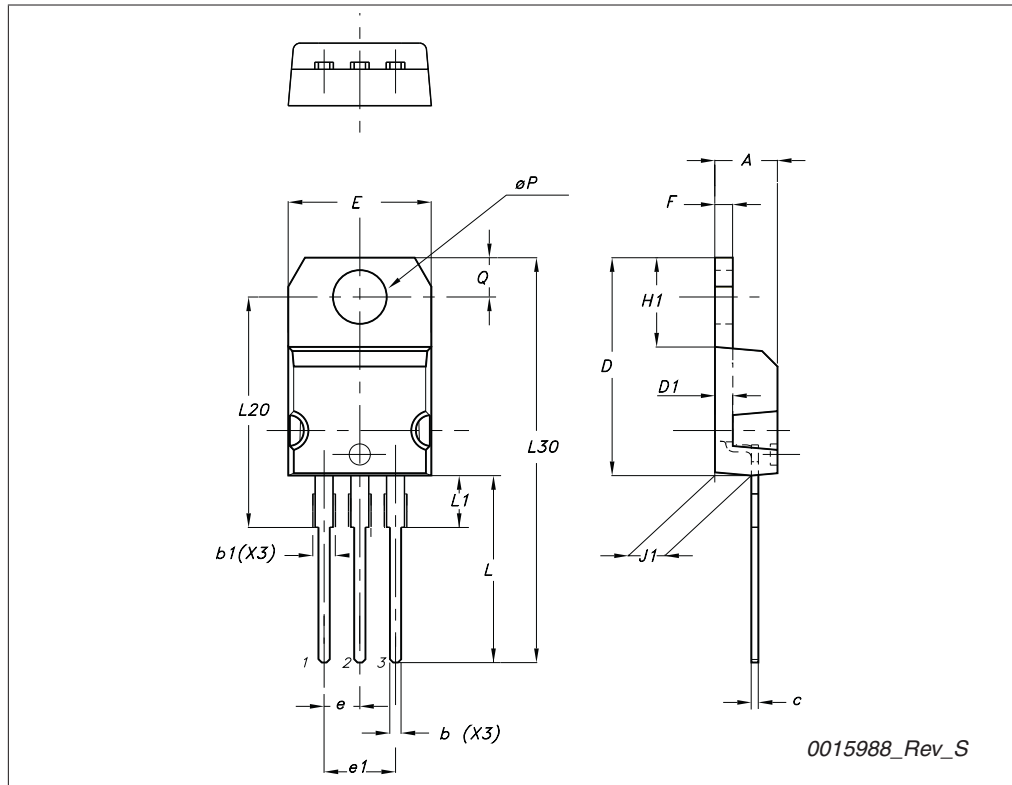

5 Packaging mechanical data

D²PAK FOOTPRINT

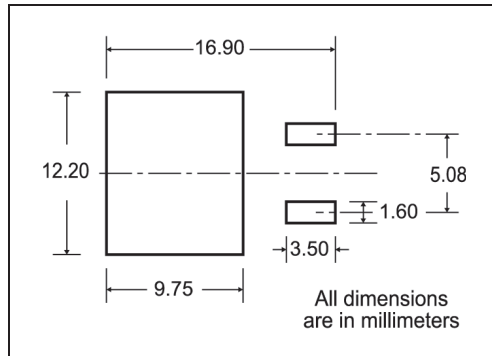

TAPE AND REEL SHIPMENT

40 mm min. Access hole at slot location

Full radius

Tape slot in core for tape start 2.5mm min. width

G measured at hub

REEL MECHANICAL DATA

DIM.	mm		inch	
	MIN.	MAX.	MIN.	MAX.
A		330		12.992
B	1.5		0.059	
C	12.8	13.2	0.504	0.520
D	20.2		0.795	
G	24.4	26.4	0.960	1.039
N	100		3.937	
T		30.4		1.197

TAPE MECHANICAL DATA

DIM.	mm		inch	
	MIN.	MAX.	MIN.	MAX.
A0	10.5	10.7	0.413	0.421
B0	15.7	15.9	0.618	0.626
D	1.5	1.6	0.059	0.063
D1	1.59	1.61	0.062	0.063
E	1.65	1.85	0.065	0.073
F	11.4	11.6	0.449	0.456
K0	4.8	5.0	0.189	0.197
P0	3.9	4.1	0.153	0.161
P1	11.9	12.1	0.468	0.476
P2	1.9	2.1	0.075	0.082
R	50		1.574	
T	0.25	0.35	0.0098	0.0137
W	23.7	24.3	0.933	0.956

TOP COVER TAPE

User Direction of Feed

FEED DIRECTION

Bending radius R min.

10 pitches cumulative tolerance on tape +/- 0.2 mm

6 Revision history

Table 9. Document revision history

Date	Revision	Changes
29-Mar-2006	1	Initial release.
03-Jun-2009	2	Document status promoted from preliminary data to datasheet.
05-Nov-2009	3	Inserted Chapter 2.1: Electrical characteristics (curves)
16-Feb-2010	4	Added new package, mechanical data: TO-220
03-Jun-2010	5	<ul style="list-style-type: none">– Added Figure 12: Thermal impedance– Modified Figure 4, Figure 5, Figure 6 and Figure 7– D²PAK mechanical data has been updated

Please Read Carefully:

Information in this document is provided solely in connection with ST products. STMicroelectronics NV and its subsidiaries ("ST") reserve the right to make changes, corrections, modifications or improvements, to this document, and the products and services described herein at any time, without notice.

All ST products are sold pursuant to ST's terms and conditions of sale.

Purchasers are solely responsible for the choice, selection and use of the ST products and services described herein, and ST assumes no liability whatsoever relating to the choice, selection or use of the ST products and services described herein.

No license, express or implied, by estoppel or otherwise, to any intellectual property rights is granted under this document. If any part of this document refers to any third party products or services it shall not be deemed a license grant by ST for the use of such third party products or services, or any intellectual property contained therein or considered as a warranty covering the use in any manner whatsoever of such third party products or services or any intellectual property contained therein.

UNLESS OTHERWISE SET FORTH IN ST'S TERMS AND CONDITIONS OF SALE ST DISCLAIMS ANY EXPRESS OR IMPLIED WARRANTY WITH RESPECT TO THE USE AND/OR SALE OF ST PRODUCTS INCLUDING WITHOUT LIMITATION IMPLIED WARRANTIES OF MERCHANTABILITY, FITNESS FOR A PARTICULAR PURPOSE (AND THEIR EQUIVALENTS UNDER THE LAWS OF ANY JURISDICTION), OR INFRINGEMENT OF ANY PATENT, COPYRIGHT OR OTHER INTELLECTUAL PROPERTY RIGHT.

UNLESS EXPRESSLY APPROVED IN WRITING BY AN AUTHORIZED ST REPRESENTATIVE, ST PRODUCTS ARE NOT RECOMMENDED, AUTHORIZED OR WARRANTED FOR USE IN MILITARY, AIR CRAFT, SPACE, LIFE SAVING, OR LIFE SUSTAINING APPLICATIONS, NOR IN PRODUCTS OR SYSTEMS WHERE FAILURE OR MALFUNCTION MAY RESULT IN PERSONAL INJURY, DEATH, OR SEVERE PROPERTY OR ENVIRONMENTAL DAMAGE. ST PRODUCTS WHICH ARE NOT SPECIFIED AS "AUTOMOTIVE GRADE" MAY ONLY BE USED IN AUTOMOTIVE APPLICATIONS AT USER'S OWN RISK.

Resale of ST products with provisions different from the statements and/or technical features set forth in this document shall immediately void any warranty granted by ST for the ST product or service described herein and shall not create or extend in any manner whatsoever, any liability of ST.

ST and the ST logo are trademarks or registered trademarks of ST in various countries.

Information in this document supersedes and replaces all information previously supplied.

The ST logo is a registered trademark of STMicroelectronics. All other names are the property of their respective owners.

© 2010 STMicroelectronics - All rights reserved

STMicroelectronics group of companies

Australia - Belgium - Brazil - Canada - China - Czech Republic - Finland - France - Germany - Hong Kong - India - Israel - Italy - Japan - Malaysia - Malta - Morocco - Philippines - Singapore - Spain - Sweden - Switzerland - United Kingdom - United States of America

www.st.com

