

Silicon Carbide Schottky Diode

FEATURES:

- Worlds first 600V Schottky diode
- Revolutionary semiconductor material - Silicon Carbide
- Switching behavior benchmark
- No reverse recovery
- No temperature influence on the switching behavior
- Ideal diode for Power Factor Correction
- No forward recovery

Applications:

- SMPS, PFC, snubber

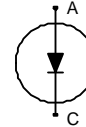

Chip Type	V _{BR}	I _F	Die Size	Package	Ordering Code
SIDC11D60SIC3	600V	4A	1.15 x 0.97 mm ²	sawn on foil	Q67050-A4161-A104

MECHANICAL PARAMETER:

Raster size	1.15 x 0.97	mm
Anode pad size	0.85 x 0.67	
Area total / active	1.116 / 0.581	mm ²
Thickness	355	µm
Wafer size	75	mm
Flat position	0	deg
Max. possible chips per wafer	3555 pcs	
Passivation frontside	Photoimide	
Anode metalization	3200 nm Al	
Cathode metalization	1400 nm Ni Ag –system suitable for epoxy and soft solder die bonding	
Die bond	electrically conductive glue or solder	
Wire bond	Al, ≤ 250µm	
Reject Ink Dot Size	∅ ≥ 0.3 mm	
Recommended Storage Environment	store in original container, in dry nitrogen, < 6 month at an ambient temperature of 23°C	

Maximum Ratings

Parameter	Symbol	Condition	Value	Unit
Repetitive peak reverse voltage	V_{RRM}		600	V
Surge peak reverse voltage	V_{RSM}		600	
Continuous forward current limited by T_{jmax}	I_F		4	A
Single pulse forward current (depending on wire bond configuration)	I_{FSM}	$T_C = 25^\circ C, t_p = 10 \text{ ms sinusoidal}$	12.5	
Maximum repetitive forward current limited by T_{jmax}	I_{FRM}	$T_C = 100^\circ C, T_j = 150^\circ C, D = 0.1$	18	
Non repetitive peak forward current	I_{FMAX}	$T_C = 25^\circ C, t_p = 10 \mu s$	40	
Operating junction and storage temperature	T_j, T_{stg}		-55...+175	°C

Static Electrical Characteristics (tested on chip), $T_j = 25^\circ C$, unless otherwise specified

Parameter	Symbol	Conditions		Value			Unit
				min.	Typ.	max.	
Reverse leakage current	I_R	$V_R = 600V$	$T_j = 25^\circ C$		15	200	μA
Forward voltage drop	V_F	$I_F = 4A$	$T_j = 25^\circ C$		1.7	1.9	V

Dynamic Electrical Characteristics, at $T_j = 25^\circ C$, unless otherwise specified, tested at component

Parameter	Symbol	Conditions		Value			Unit
				min.	Typ.	max.	
Total capacitive charge	Q_C	$I_F = 4A$ $di/dt = 200A/ms$ $V_R = 400V$	$T_j = 150^\circ C$		13		nC
Switching time	t_{rr}	$I_F = 4A$ $di/dt = 200A/ms$ $V_R = 400V$	$T_j = 150^\circ C$		n.a.		ns
Total capacitance	C	$I_F = 4A$ $di/dt = 200A/ms$ $T_j = 25^\circ C$ $f = 1MHz$	$V_R = 1V$		150		pF
			$V_R = 300V$		10		
			$V_R = 600V$		7		

CHIP DRAWING:

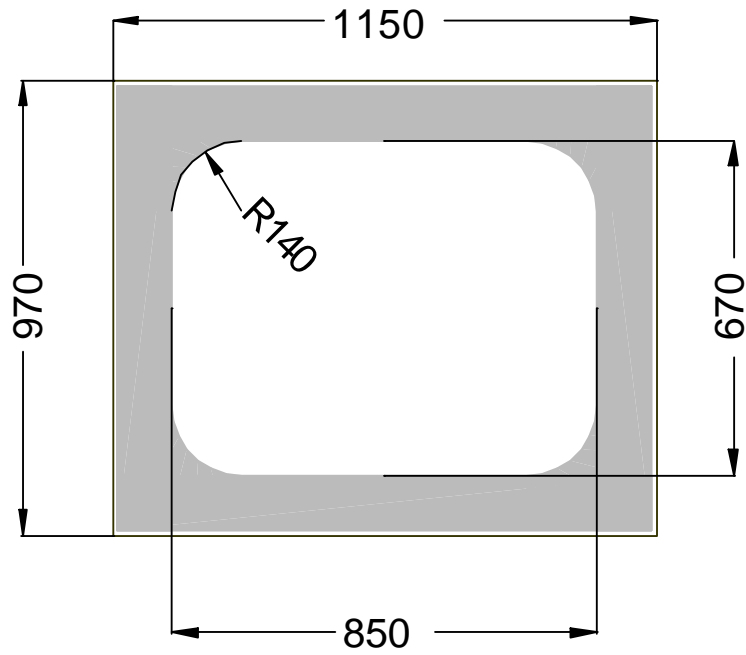



SIDC11D60SIC3

FURTHER ELECTRICAL CHARACTERISTICS:

This chip data sheet refers to the device data sheet

INFINEON TECHNOLOGIES

SDP04S60

Description:

AQL 0,65 for visual inspection according to failure catalog

Electrostatic Discharge Sensitive Device according to MIL-STD 883

Test-Normen Villach/Prüffeld

Published by
Infineon Technologies AG
Bereich Kommunikation
St.-Martin-Strasse 53
D-81541 München
© Infineon Technologies AG 2000
All Rights Reserved.

Attention please!

The information herein is given to describe certain components and shall not be considered as warranted characteristics.

Terms of delivery and rights to technical change reserved.

We hereby disclaim any and all warranties, including but not limited to warranties of non-infringement, regarding circuits, descriptions and charts stated herein.

Infineon Technologies is an approved CECC manufacturer.

Information

For further information on technology, delivery terms and conditions and prices please contact your nearest Infineon Technologies Office in Germany or our Infineon Technologies Representatives world-wide (see address list).

Warnings

Due to technical requirements components may contain dangerous substances. For information on the types in question please contact your nearest Infineon Technologies Office.

Infineon Technologies components may only be used in life-support devices or systems with the express written approval of Infineon Technologies, if a failure of such components can reasonably be expected to cause the failure of that life-support device or system, or to affect the safety or effectiveness of that device or system. Life support devices or systems are intended to be implanted in the human body, or to support and / or maintain and sustain and / or protect human life. If they fail, it is reasonable to assume that the health of the user or other persons may be endangered.