

**Features**

- XTREMELY Low Jitter
- Low Cost
- XPRESS Delivery
- Frequency Resolution to six decimal places
- Absolute Pull Range (APR) of  $\pm 50\text{ppm}$
- -20 to +70°C or -40 to +85°C operating temperatures
- Tri-State Enable / Disable Feature
- Industry Standard Package, Footprint & Pin-Out
- Fully RoHS compliant
- Gold over Nickel Termination Finish
- Serial ID with Comprehensive Traceability



**Applications**

- ANY application requiring an oscillator
- SONET
- Ethernet
- Storage Area Network
- Broadband Access
- Microprocessors / DSP / FPGA
- Industrial Controllers
- Test and Measurement Equipment
- Fiber Channel

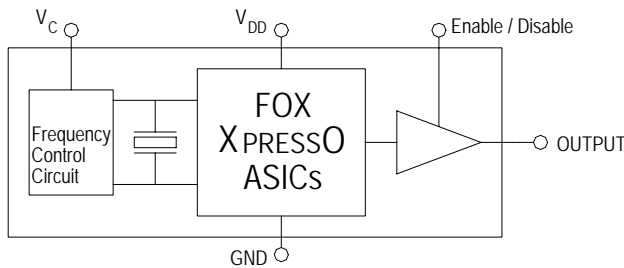

For more information -- Click on the drawing

**Description**

The Fox XPRESSO Crystal Oscillator is a breakthrough in configurable Frequency Control Solutions. XPRESSO utilizes a family of proprietary ASICs, designed and developed by Fox, with a key focus on noise reduction technologies.

The 3<sup>rd</sup> order Delta Sigma Modulator reduces noise to the levels that are comparable to traditional Bulk Quartz and SAW oscillators. The ASICs family has ability to select the output type, input voltages, and temperature performance features.

With the XPRESS lead-time, low cost, low noise, wide frequency range, excellent ambient performance, XpressO is an excellent choice over the conventional technologies.

Finished XPRESSO parts are 100% final tested.

**Contents**

	page
Model Selection & Part Number Guide	2
Electrical Characteristic	3
Absolute Maximums	4
Output Wave Characteristics	4
Phase Noise	5
Jitter	5
Pin Assignment	6
Recommended Circuit	6
Reflow	6
Mechanical Drawing and Pad Layout	7
Tape and Reel Specification	8
Label	8
Traceability – LOT Number & Serial Identification	9
RoHS Material Declaration	10
SGS Report	11 & 12
Mechanical Test	13
Burn-In Test	13
MTTF / FITS calculations	14
Other XPRESSO Links	15
Fox Contact Information	15

## Model Selection Guide & Fox Part Number

**STEP #1:** Customer selects the Model Description and provides to Fox Customer Service

### Model Description

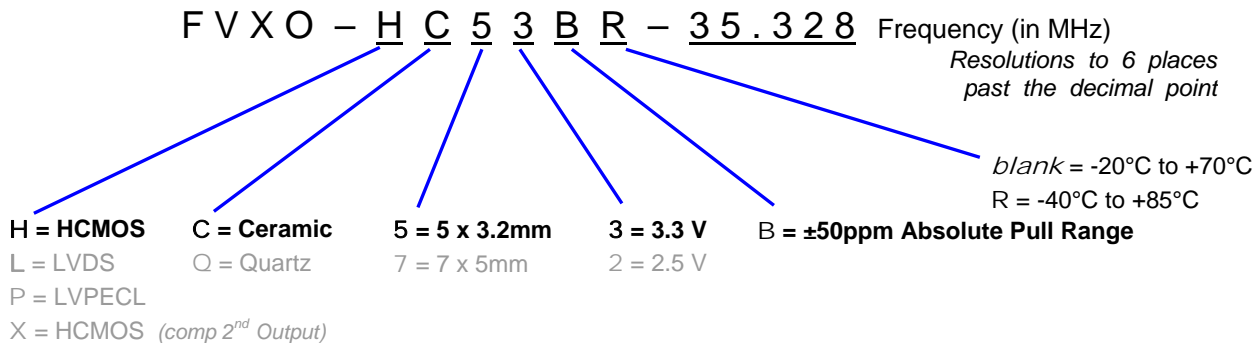

**STEP #2:** The Fox Customer Service team provides a customer specific Part Number for use on their Bill Of Materials (BOM).

**Fox Part Number** *(The assigned Fox Part Number must be on the BOM – not the above Model Description)*  
*(This will ensure receipt of the proper part)*

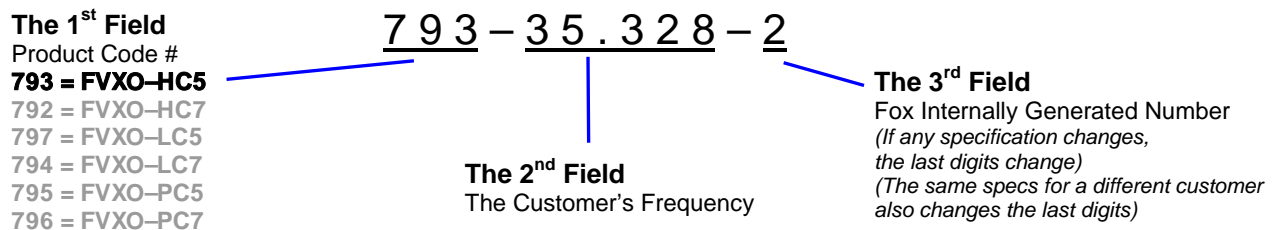

**This example, FVXO-HC53BR-35.328 = Voltage Controlled, HCMOS Output, Ceramic, 5 x 3.2mm Package, 3.3V, ±50 PPM Absolute Pull Range, -40 to +85°C Temperature Range, at 35.328 MHz**

## Absolute Maximum Ratings *(Useful life may be impaired. For user guidelines only, not tested)*

Parameters	Symbol	Condition	Maximum Value (unless otherwise noted)
Input Voltage	V <sub>DD</sub>		-0.5V to +5.0V
Operating Temperature	T <sub>AMAX</sub>		-55°C to +105°C
Storage Temperature	T <sub>STG</sub>		-55°C to +125°C
Junction Temperature			150°C
ESD Sensitivity	HBM	Human Body Model	1 kV

Electrical Characteristics			
Parameters	Symbol	Condition	Maximum Value (unless otherwise noted)
Frequency Range	$F_O$		0.750 to 250.000 MHz
Absolute Pull Range <sup>Note 1</sup>	APR		± 50 ppm MIN
Temperature Range	$T_O$	Standard operating	-20°C to +70°C
	$T_{STG}$	Optional operating Storage	-40°C to +85°C -55°C to +125°C
Supply Voltage	$V_{DD}$	Standard	3.3 V ± 5%
Input Current (@ 15pF LOAD)	$I_{DD}$	0.75 ~ 20 MHz	32 mA
		20+ ~ 50 MHz	35 mA
		50+ ~ 130 MHz	47 mA
		130+ ~ 200 MHz	55 mA
		200+ ~ 250 MHz	60 mA
Output Load	HCMOS	Standard	15 pF
		Operational To 125MHz	30 pF
Start-Up Time	$T_s$		10 mS
Output Enable / Disable Time			100 nS
Moisture Sensitivity Level	MSL	JEDEC J-STD-20	1
Termination Finish			Au

Note 1 – Inclusive of 25°C tolerance, operating temperature range, input voltage change, load change, aging, shock and vibration.

Frequency Control ( $V_C$ ) Input -- pin # 1			
Parameters	Symbol	Condition	Maximum Value (unless otherwise noted)
Control Voltage Tuning Slope <sup>1</sup>		0V to $V_{DD}$	40 ~ 75 ppm/V Typ <sup>2</sup>
Control Voltage Linearity <sup>2</sup>	$L_{VC}$		± 10%
Control Voltage Tuning Range	$V_C$		0V ~ 3.3V
Modulation Bandwidth	BW		10 kHz
Nominal Control Voltage	$V_{CNOM}$	@ $f_0$	1.65V

**NOTES:**

- <sup>1</sup> Actual slope is affected by frequency and accuracy settings.
- <sup>2</sup> For an example of linearity, see the graph below. (The middle line represents the default Fox factory setting)

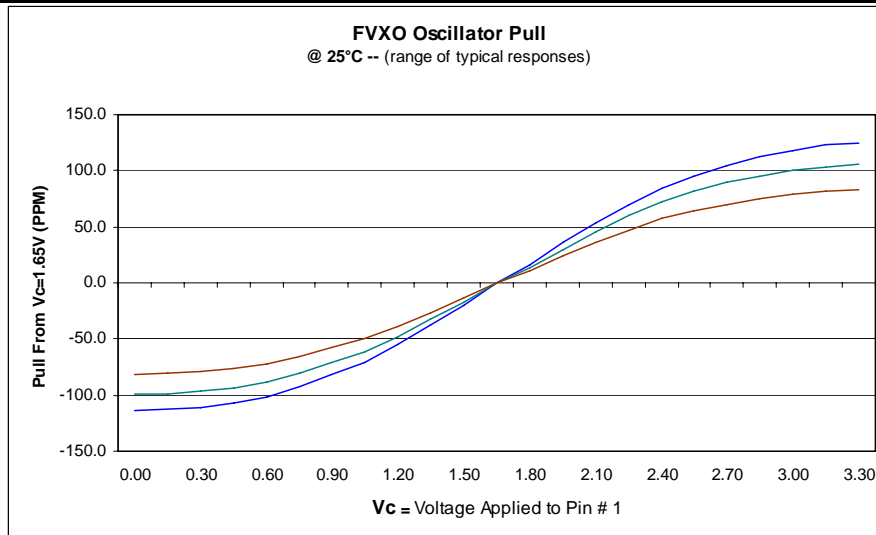

**Output Wave Characteristics**

Parameters	Symbol	Condition	Maximum Value (unless otherwise noted)
Output LOW Voltage	$V_{OL}$	0.75 to 150 MHz 150+ to 250 MHz	10% $V_{DD}$ 20% $V_{DD}$
Output HIGH Voltage	$V_{OH}$	0.75 to 150 MHz 150+ to 250 MHz	90% $V_{DD}$ MIN 80% $V_{DD}$ MIN
Output Symmetry (See Drawing Below)		@ 50% $V_{DD}$ Level	45% ~ 55%
Output Enable (PIN # 2) Voltage	$V_{IH}$		> 70% $V_{DD}$
Output Disable (PIN # 2) Voltage	$V_{IL}$		< 30% $V_{DD}$
Cycle Rise Time (See Drawing Below)	$T_R$	0.75 to 150 MHz 150+ to 250 MHz	3 nS (10%-90%) 3 nS (20%-80%)
Cycle Fall Time (See Drawing Below)	$T_F$	0.75 to 150 MHz 150+ to 250 MHz	3 nS (90%-10%) 3 nS (80%-20%)

If 30% to 70% times are used, Rise and Fall times change to 1.5 nS from 0.75 to 250MHz  
 If 20% to 80% times are used, Rise and Fall times change to 2 nS from 0.75 to 150MHz

**Rise Time / Fall Time Measurements**

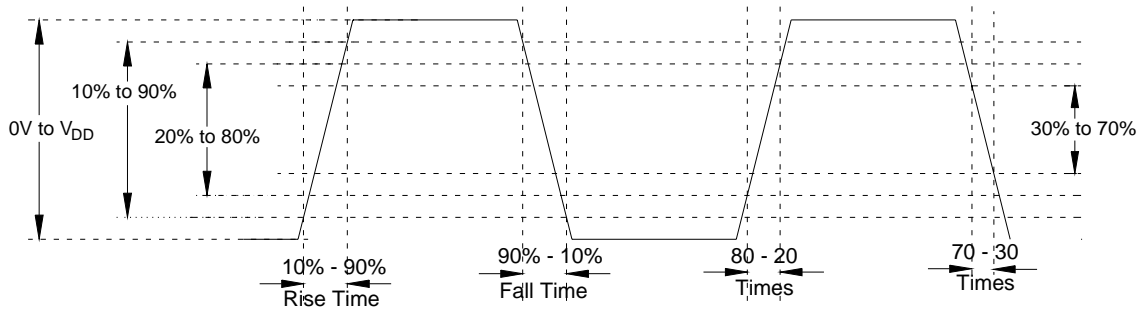

**Oscillator Symmetry**

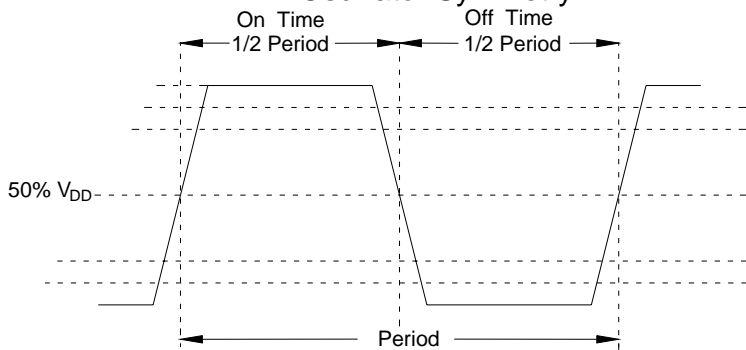

Ideally, Symmetry should be 50/50 -- Other expressions are 45/55 or 55/45

**Phase Noise**

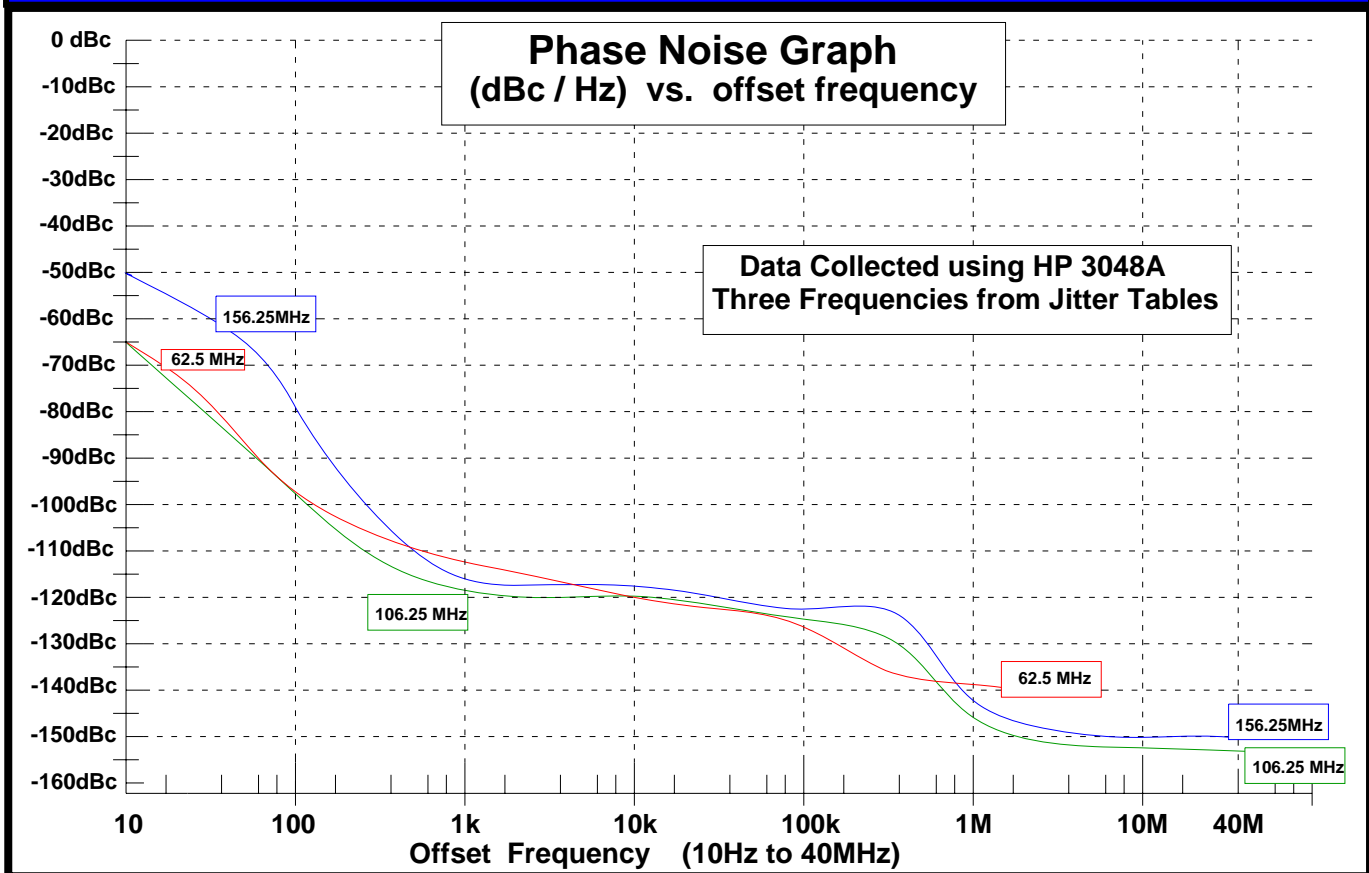

Jitter is frequency dependent. Below are typical values at select frequencies.

**Phase Jitter & Time Interval Error (TIE)**

Frequency	Phase Jitter (12kHz to 20MHz)	TIE (Sigma of Jitter Distribution)	Units
62.5 MHz	0.93	2.8	pS RMS
106.25 MHz	0.86	3.2	pS RMS
125 MHz	0.75	2.7	pS RMS
156.25 MHz	0.77	3.3	pS RMS

**Phase Jitter** is integrated from HP3048 Phase Noise Measurement System; measured directly into 50 ohm input;  $V_{DD} = 3.3V$ .  
**TIE** was measured on LeCroy LC684 Digital Storage Scope, directly into 50 ohm input, with Amherst M1 software;  $V_{DD} = 3.3V$ .  
 Per **MJSQ spec** (Methodologies for Jitter and Signal Quality specifications)

**Random & Deterministic Jitter Composition**

Frequency	Random (Rj) (pS RMS)	Deterministic (Dj) (pS P-P)	Total Jitter (Tj) (14 x Rj) + Dj
62.5 MHz	1.28	6.8	25.1 pS
106.25 MHz	1.28	8.4	26.6 pS
125 MHz	1.20	8.0	25.2 pS
156.25 MHz	1.27	8.6	26.6 pS

**Rj and Dj**, measured on LeCroy LC684 Digital Storage Scope, directly into 50 ohm input, with Amherst M1 software.  
 Per **MJSQ spec** (Methodologies for Jitter and Signal Quality specifications)



### Pin Description and Recommended Circuit

Pin #	Name	Type	Function
1	V <sub>C</sub>	Control	Frequency Control by changing voltage
2	E / D <sup>1</sup>	Logic	Enable / Disable Control of Output (0 = Disabled)
3	GND	Ground	Electrical Ground for V <sub>DD</sub>
4	Output	Output	HCMOS Oscillator Output
5	N. C.	Hi Z	No Connection (Factory Use ONLY)
6	V <sub>DD</sub> <sup>2</sup>	Power	Power Supply Source Voltage

**NOTES:**

- <sup>1</sup> Includes pull-up resistor to V<sub>DD</sub> to provide output when the pin (2) is No Connect.
- <sup>2</sup> Installation should include a 0.01μF bypass capacitor placed between V<sub>DD</sub> (Pin 6) and GND (Pin 3) to minimize power supply line noise.

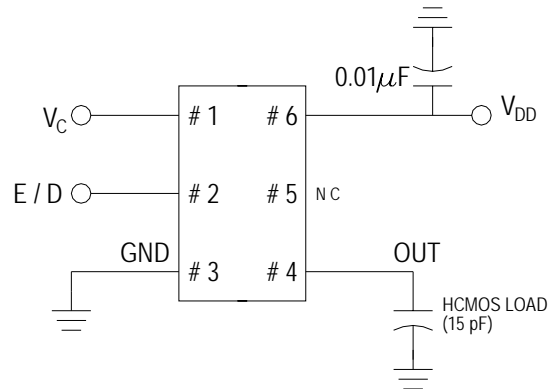
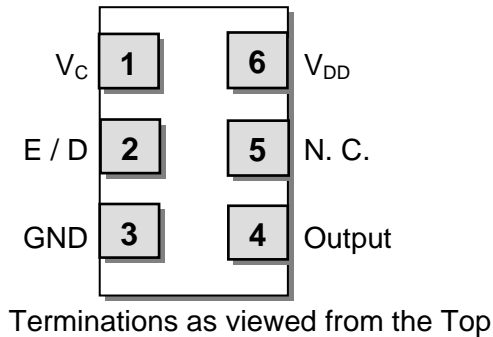

### Enable / Disable Control

Pin # 2 (state)	Output (Pin # 4)
OPEN (No Connection)	ACTIVE Output
"1" Level V <sub>IH</sub> > 70% V <sub>DD</sub>	ACTIVE Output
"0" Level V <sub>IL</sub> < 30% V <sub>DD</sub>	High Impedance

### Soldering Reflow Profile (2 times Maximum at 260°C for 10 seconds MAX)

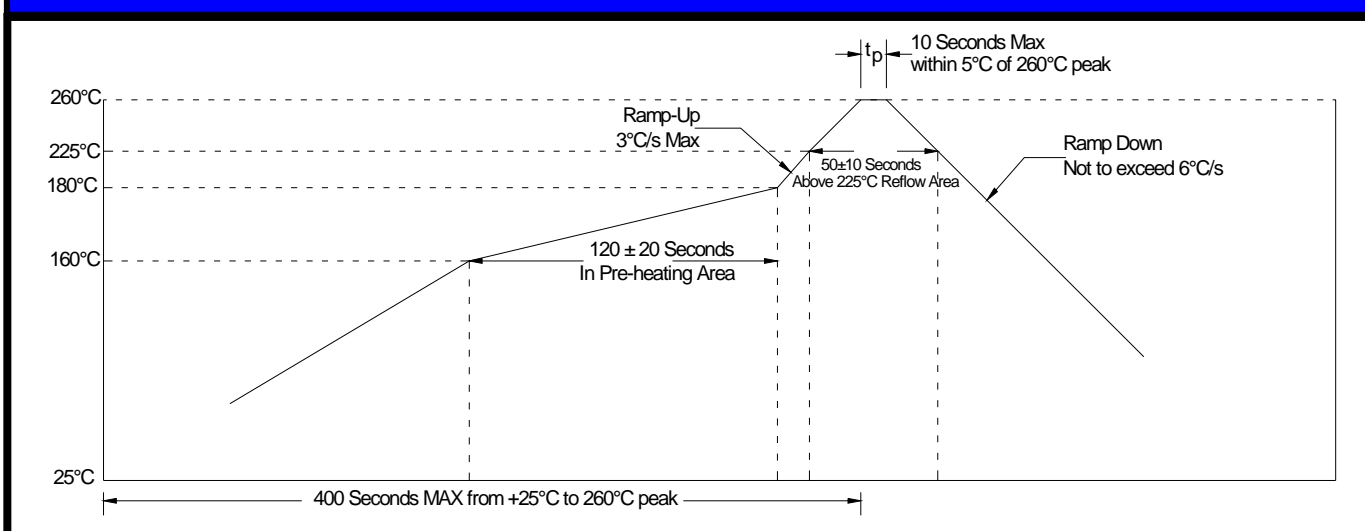

**Mechanical Dimensional Drawing & Pad Layout**

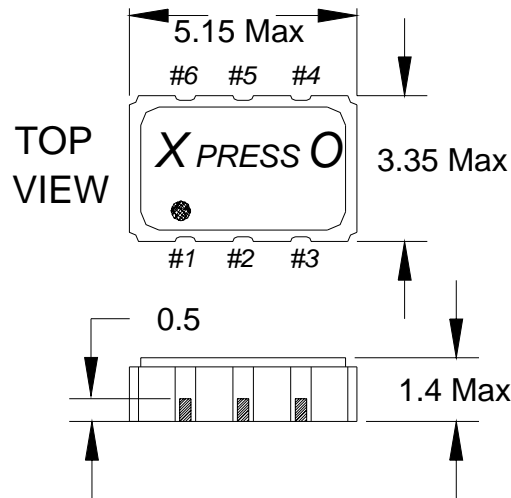

**Actual part marking is depicted.**  
See **Traceability** (pg. 9) for more information

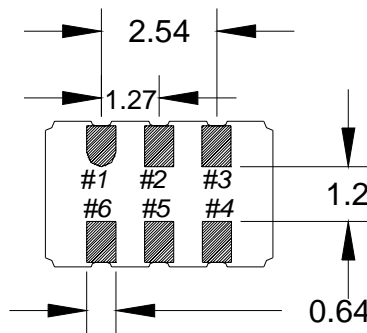

**Recommended Solder Pad Layout**

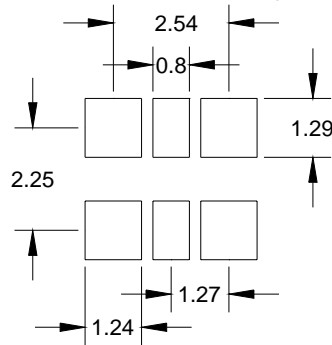

**Pin Connections**

- |           |              |
|-----------|--------------|
| #1) $V_C$ | #4) Output   |
| #2) E/D   | #5) NC       |
| #3) GND   | #6) $V_{DD}$ |

Drawing is for reference to critical specifications defined by size measurements. Certain non-critical visual attributes, such as side castellations, reference pin shape, etc. may vary

**Tape and Reel Dimensions**

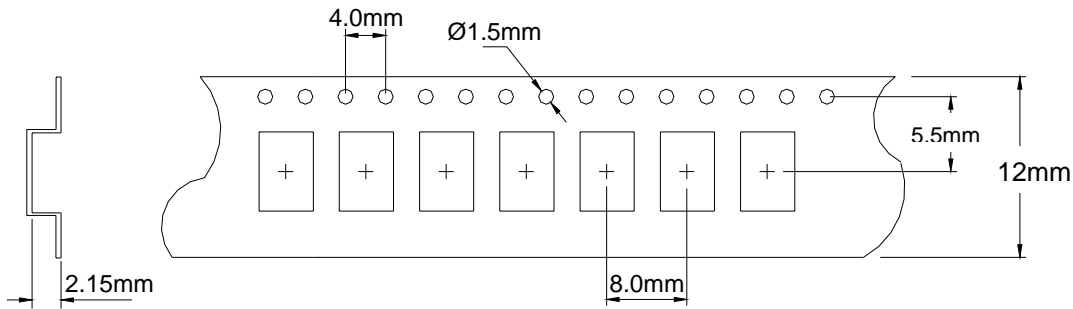

**1k Reel Dimensions in mm**

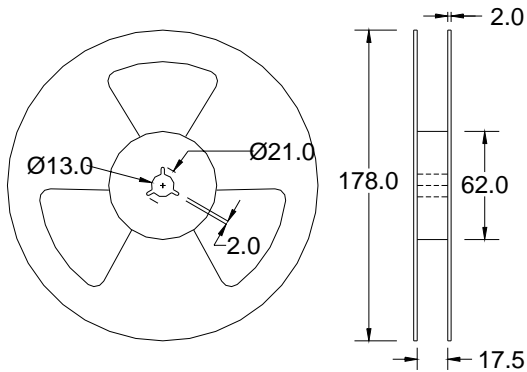

**2k Reel Dimensions in mm**

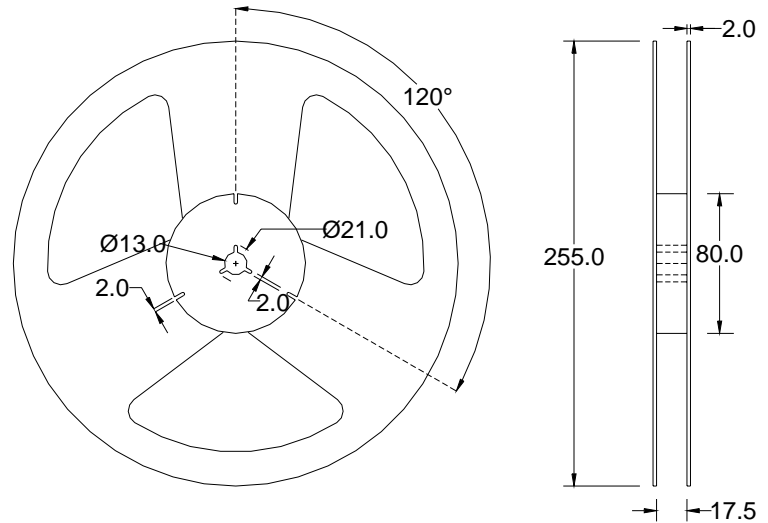

**Labeling** (Reels and smaller packaging are labeled with the below)

- Fox Part Number: **793-35.328-2** →
- Quantity: **2000** pieces →
- Description: **FVXO-HC53BR-35.328** →
- Date Code: **0745** →  
(YYWW 2007 45<sup>th</sup> wk)
- LOT #: **24435** →  
*If traceability should become necessary*

An additional identification code is contained internally if tracking should ever be necessary



## Traceability – LOT Number & Serial Identification

### LOT Number

The LOT Number has direct ties to the customer purchase order. The LOT Number is marked on the “Reel” label, and also stored internally on non-volatile memory inside the XPRESSO part. XPRESSO parts that are shipped Tape and Reel, are also placed in an Electro Static Discharge (ESD) bag and will have the LOT Number labeled on the exterior of the ESD bag.

It is recommended that the XPRESSO parts remain in this ESD bag during storage for protection and identification.

If the parts become separated from the label showing the LOT Number, it can be retrieved from inside one of the parts, and the information that can be obtained is listed below:

- Customer Purchase Order Number
- Internal Fox Sales Order Number
- Dates that the XPRESSO part was shipped from the factory
- The assigned customer part number
- The specification that the part was designed for

---

### Serial Identification

The Serial ID is the individualized information about the configuration of that particular XPRESSO part. The Serial ID is unique for each and every XPRESSO part, and can be read by special Fox equipment.

With the Serial ID, the below information can be obtained about that individual, XPRESSO part:

- Equipment that the XPRESSO part was configured on
- Raw material used to configure the XPRESSO part
- Traceability of the raw material back to the foundries manufacturing lot
- Date and Time that the part was configured
- Any optimized electrical parameters based on customer specifications
- Electrical testing of the actual completed part
- Human resource that was monitoring the configuration of the part

Fox has equipment placed at key Fox locations World Wide to read the Lot Identification and Serial Number of any XPRESSO part produced and can then obtain the information from above within 24 hours

**RoHS Material Declaration**

	Material Name	Component	Content (mg)	Content (w t %)	(CAS Number)
Cover	Kovar	Nickel (Ni)	1.890	3.09%	7440-02-0
		Cobalt (Co)	1.113	1.82%	7440-48-4
		Iron (Fe)	3.540	5.78%	7439-89-6
Base	Ceramic	Alumina (Al <sub>2</sub> O <sub>3</sub> )	35.484	57.98%	1344-28-1
		Silicon Oxide (SiO <sub>2</sub> )	1.733	2.83%	14808-60-7
		Chromium Oxide (Cr <sub>2</sub> O <sub>3</sub> )	0.268	0.44%	1308-38-9
		Molybdenum Oxide (MoO <sub>2</sub> )	0.364	0.59%	18868-43-4
		Magnesium Oxide (MgO)	0.234	0.38%	1309-48-4
		Calcium Oxide (CaO)	0.253	0.41%	1305-78-8
	+ Metallization	Tungsten (W)	6.290	10.28%	7440-33-7
		Molybdenum (Mo)	0.195	0.32%	7439-98-7
	+ Nickel Plating	Nickel (Ni)	0.810	1.32%	7440-02-0
		Cobalt (Co)	0.203	0.33%	7440-48-4
	+ Gold Plating	Gold (Au)	0.281	0.46%	7440-57-5
	+ Seal ring	Iron (Fe)	2.438	3.98%	7439-89-6
		Nickel (Ni)	1.309	2.14%	7440-02-0
		Cobalt (Co)	0.768	1.25%	7440-48-4
	+ silver solder	Silver (Ag)	1.191	1.95%	7440-22-4
		Copper (Cu)	0.210	0.34%	7440-50-8
	I C	I C	Aluminum (Al)	0.0021	0.00343%
Silicon (Si)			0.950	1.55%	7440-21-3
Gold		Gold (Au)	0.480	0.784%	7440-57-5
Adhesive		Silver (Ag)	0.000210	0.000343%	7440-22-4
		Epoxy	0.0000700	0.0001144%	
Crystal	Crystal	Silicon Dioxide (SiO <sub>2</sub> )	1.170	1.91%	14808-60-7
	Electrode	Silver (Ag)	0.019	0.0310%	7440-22-4
		Nickel (Ni)	0.000159	0.000260%	7440-02-0
	Adhesive	Silver (Ag)	0.00037	0.000605%	7440-22-4
		Silicon (Si)	0.000125	0.000204%	7440-21-3
<b>TOTAL</b>			<b>61.196</b>	<b>100.00%</b>	

**3<sup>rd</sup> Party (SGS) Material Report****Test Report**

No. 2053204/EC

Date : Mar 01 2006

Page 1 of 2

FOX ELECTRONICS  
5570 ENTERPRISE PARKWAY  
FT. MYERS, FL 33905

Report on the submitted sample said to be CERAMIC SEAM SEAL OSCILLATOR.

SGS Job No. : 1981176  
Supplier / Manufacturer : FOX ELECTRONICS  
Sample Receiving Date : FEB 17 2006  
Testing Period : FEB 18 - 24 2006

Test Requested : 1) To determine the Cadmium Content in the submitted sample.  
2) To determine the Lead Content in the submitted sample.  
3) To determine the Mercury Content in the submitted sample.  
4) To determine the Hexavalent Chromium Content on the submitted sample.  
5) To determine PBBs (polybrominated biphenyls) and PBDEs (Polybrominated diphenylethers) of the submitted sample.

Test Method : 1-3) With reference to EPA Method 3051/ 3052.  
Analysis was performed by Inductively Coupled Argon Plasma-Atomic Emission Spectrometry (ICP-AES).  
4) With reference to EPA Method 3060A & 7196A.  
The sample was alkaline digested by using EPA Method 3060A, and then analyzed by using Colorimetric method 7196A (by UV-Vis Spectrophotometer).  
5) With reference to EPA Method 3540C/ 3550C. Analysis was performed by GC/MS or LC/ MS.

Test Results : 1-5) Please refer to next page.

Signed for and on behalf of  
SGS Hong Kong Ltd

  
 \_\_\_\_\_  
 Ho Ka Ting, Family  
Laboratory Executive

This Test Report is issued by the Company subject to its General Conditions of Service printed overleaf. Attention is drawn to the limitations of liability, indemnification and jurisdictional issues defined therein. The results shown in this test report refer only to the sample(s) tested unless otherwise stated. This Test Report cannot be reproduced, except in full, without prior written permission of the Company.

3<sup>rd</sup> Party (SGS) Material Report (continued)



**Test Report**

No. 2053204/EC

Date : Mar 01 2006

Page 2 of 2

Test Results :

Test Item	1	Detection Limit
1) Cadmium (Cd)	ND	2 ppm
2) Lead (Pb)	ND	2 ppm
3) Mercury (Hg)	ND	2 ppm
4) Hexavalent Chromium (Cr <sup>6+</sup> )	ND	2 ppm

(Results shown are of the total weight of samples)

Note : ppm = mg/kg  
 ND = Not Detected  
 Not detected is reported when the reading is less than detection limit value

5)

Flame Retardants	1	Detection Limit
<b>Polybrominated Biphenyls (PBBs)</b>	---	---
Monobromobiphenyl	ND	5 ppm
Dibromobiphenyl	ND	5 ppm
Tribromobiphenyl	ND	5 ppm
Tetrabromobiphenyl	ND	5 ppm
Pentabromobiphenyl	ND	5 ppm
Hexabromobiphenyl	ND	5 ppm
Heptabromobiphenyl	ND	5 ppm
Octabromobiphenyl	ND	5 ppm
Nonabromobiphenyl	ND	5 ppm
Decabromobiphenyl	ND	5 ppm
<b>Polybrominated Diphenylethers (PBDEs)</b>	---	---
Monobromodiphenyl ether	ND	5 ppm
Dibromodiphenyl ether	ND	5 ppm
Tribromodiphenyl ether	ND	5 ppm
Tetrabromodiphenyl ether	ND	5 ppm
Pentabromodiphenyl ether	ND	5 ppm
Hexabromodiphenyl ether	ND	5 ppm
Heptabromodiphenyl ether	ND	5 ppm
Octabromodiphenyl ether	ND	5 ppm
Nonabromodiphenyl ether	ND	5 ppm
Decabromodiphenyl ether	ND	5 ppm

Note : ppm = mg/kg  
 ND = Not Detected  
 Not detected is reported when the reading is less than detection limit value.

Sample Description:

1. Black Ceramic w/ Silvery, Golden Metal w/ Silvery Chips

\*\*\* End of Report \*\*\*

This Test Report is issued by the Company subject to its General Conditions of Service printed overleaf. Attention is drawn to the limitations of liability, indemnification and jurisdictional issues defined therein. The results shown in this test report refer only to the sample(s) tested unless otherwise stated. This Test Report cannot be reproduced, except in full, without prior written permission of the Company.



**Mechanical Testing**

Parameter	Test Method
Mechanical Shock	Drop from 75cm to hardwood surface – 3 times
Mechanical Vibration	10~55Hz, 1.5mm amplitude, 1 Minute Sweep 2 Hours each in 3 Directions (X, Y, Z)
High Temperature Burn-in	Under Power @ 125°C for 2000 Hours (results below)
Hermetic Seal	He pressure: 4 ±1 kgf / cm <sup>2</sup> 2 Hour soak

**2,000 Hour Burn-In**

**Burn-In Testing** – under power 2000 Hours, 125°C

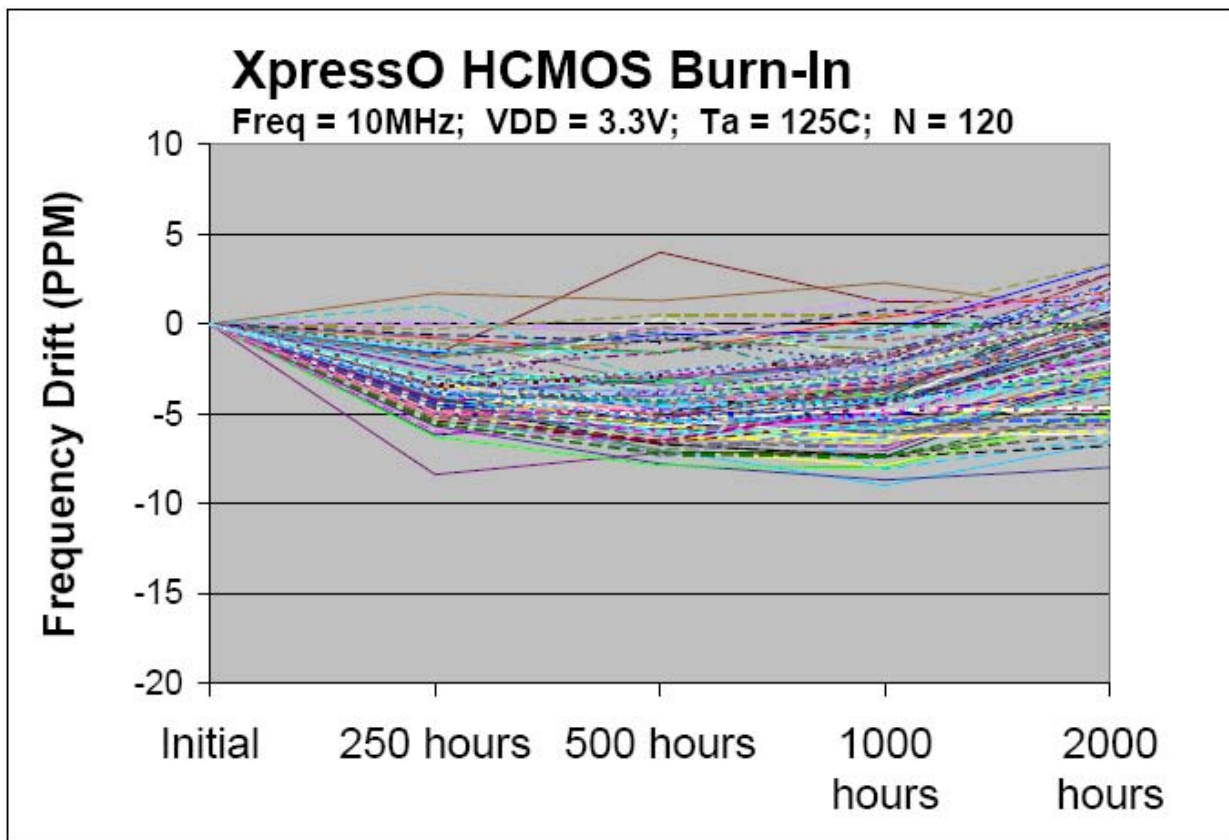

## MTTF / FITS Calculations

Products are grouped together by process for MTTF calculations.  
 (All XpressO output and package types are manufactured with the same process)

Number of Parts Tested: 360 (120 of each output type: HCMOS, LVDS, LVPECL)  
Number of Failures: 0  
Test Temperature: 125°C  
Number of Hours: 2000

MTTF was calculated using the following formulas:

[1.] Device Hours (*devhrs*) = (number of devices) x (hours at elevated temperature in °K)

$$[2.] \text{MTTF} = \frac{\text{devhrs} \times af \times 2}{\chi^2}$$

$$[3.] \text{FITS} = \frac{1}{\text{MTTF}} * 10^9$$

Where:

<b>Label</b>	<b>Name</b>	<b>Formula/Value</b>
<i>af</i>	Acceleration Factor	$e^{\left(\frac{eV}{k}\right) \times \left(\frac{1}{t_1} - \frac{1}{t_2}\right)}$
<i>eV</i>	Activation Energy	0.40 V
<i>k</i>	Bolzman's Constant	8.62 X 10 <sup>-5</sup> eV/°K
<i>t<sub>1</sub></i>		Operating Temperature (°K)
<i>t<sub>2</sub></i>		Accelerated Temperature (°K)
$\Theta$	Theta	Confidence Level (60% industry standard)
<i>r</i>	Failures	Number of failed devices
$\chi^2$	Chi-Square	statistical significance for bivariate tabular analysis [table look-up] based on assumed $\Theta$ (Theta – confidence) and number of failures ( <i>r</i> ) For zero failures (60% Confidence): $\chi^2 = 1.830$

$$\text{DEVICE-HOURS} = 360 \times 2000 \text{ HOURS} = 720,000$$

$$\text{ACCELERATION FACTOR} = e^{\left(\frac{0.40}{8.625}\right) \times \left(\frac{1}{298} - \frac{1}{398}\right)} = 49.91009$$

$$\text{MTTF} = \frac{720,000 \times 49.91009 \times 2}{1.833} = 15,607,065 \text{ Hours}$$

$$\text{Failure Rate} = \frac{1.833}{720,000 \times 49.91009 \times 2} = 6.41\text{E-}8$$

$$\text{FITS} = \text{Failure Rate} * 1\text{E}9 = 64$$

**Notes :**

**Other XPRESSO Links**

[XPRESSO Brochure](#)

Crystal Oscillators
<a href="#">HCMOS 5 x 3.2mm 3.3V XO 0.75 to 250MHz</a>
<a href="#">HCMOS 7 x 5mm 3.3V XO 0.75 to 250MHz</a>
<a href="#">LVPECL 5 x 3.2mm 3.3V XO 0.75 to 1.35GHz</a>
<a href="#">LVPECL 7 x 5mm 3.3V XO 0.75 to 1.35GHz</a>
<a href="#">LVDS 5 x 3.2mm 3.3V XO 0.75 to 1.35GHz</a>
<a href="#">LVDS 7 x 5mm 3.3V XO 0.75 to 1.35GHz</a>
Voltage Controlled Crystal Oscillators
<a href="#">HCMOS 5 x 3.2mm 3.3V VCXO 0.75 to 250MHz</a>
<a href="#">HCMOS 7 x 5mm 3.3V VCXO 0.75 to 250MHz</a>
<a href="#">LVPECL 5 x 3.2mm 3.3V VCXO 0.75 to 1.35GHz</a>
<a href="#">LVPECL 7 x 5mm 3.3V VCXO 0.75 to 1.35GHz</a>
<a href="#">LVDS 5 x 3.2mm 3.3V VCXO 0.75 to 1.35GHz</a>
<a href="#">LVDS 7 x 5mm 3.3V VCXO 0.75 to 1.35GHz</a>

[Main Website www.foxonline.com](http://www.foxonline.com)

Patent Numbers:  
 US 6,664,860, US 5,960,403, US 5,952,890; US 5,960,405; US 6,188,290;  
 Foreign Patents: R.S.A. 98/0866, R.O.C. 120851; Singapore 67081, 67082; EP 0958652  
 China ZL 98802217.6, Malaysia MY-118540-A, Philippines 1-1998-000245, Hong Kong #HK1026079, Mexico #232179  
 US and Foreign Patents Pending  
 XpressO™ Fox Electronics

Contact Information	Fox Hong Kong	Fox Japan
<p><a href="#">(USA)-Worldwide Headquarters</a></p> <p>Tel: 888-GET-2-FOX                      Outside US: +1.239.693.0099,                      Fax: +1.239.693.1554                      Email: <a href="http://www.foxonline.com/email.htm">www.foxonline.com/email.htm</a></p>	<p>Tel: +852.2854.4285,                      Fax: +852.2854.4282                      Email: <a href="http://www.foxonline.com/email.htm">www.foxonline.com/email.htm</a></p> <p><a href="#">Fox EMEA</a></p> <p>Tel/Fax: +44.1767.312632                      Email: <a href="http://www.foxonline.com/email.htm">www.foxonline.com/email.htm</a></p>	<p>Tel: +81.3.3374.2079,                      Fax: +81.3.3377.5221                      Email: <a href="http://www.foxonline.com/email.htm">www.foxonline.com/email.htm</a></p> <p><a href="#">Fox Taiwan</a></p> <p>Tel: +886-2-22073427,                      Fax: +886-2-22073486                      Email: <a href="http://www.foxonline.com/email.htm">www.foxonline.com/email.htm</a></p>

The above specifications, having been carefully prepared and checked, is believed to be accurate at the time of publication; however, no responsibility is assumed by Fox Electronics for inaccuracies.

