

INTERNATIONAL RECTIFIER

IRD3899, IRD3909 SERIES

20 and 30 Amp Fast Recovery Rectifier Diodes

Major Ratings and Characteristics

	IRD3899 -IRD3903	IRD3909 -IRD3913		
$I_{F(AV)}$	20	30	A	
@ Max. T_C	100	100	$^{\circ}C$	
I_{FSM}	50Hz	240	285	A
	60Hz	250	300	A
I^2t	50Hz	285	410	A^2s
	60Hz	260	375	A^2s
$I^2\sqrt{t}$	4050	5810	$A^2\sqrt{s}$	
t_{rr} range	see table		ns	
V_{RRM} range	50-400		V	
T_J range	-40 to 125		$^{\circ}C$	

Description

This range of fast recovery diodes is designed for applications in DC power supplies, inverters, choppers, ultrasonic systems and for use as a free-wheeling diode.

Features

- Short reverse recovery time
- Low stored charge
- Wide current range
- Excellent surge capabilities
- Stud cathode and stud anode versions

CASE STYLE AND DIMENSIONS

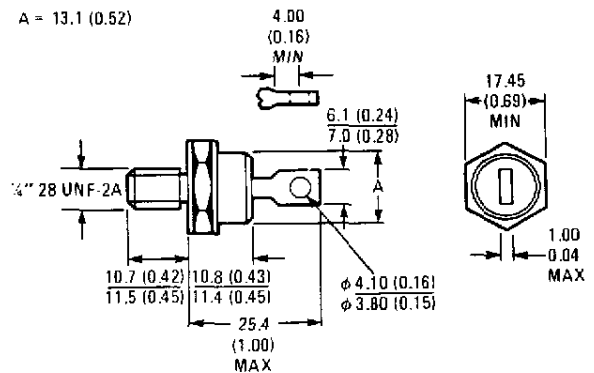
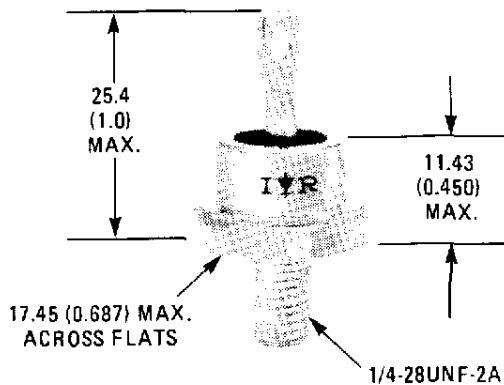

Conforms to JEDEC Outline DO-203AB (DO-5)
All Dimensions in Millimeters and (Inches)

ELECTRICAL SPECIFICATIONS

Reverse voltage ratings

Part number ①	V _{RRM} , Maximum peak repetitive reverse voltage T _J = -40 to 125°C	V _{RSM} , Maximum peak non-repetitive reverse voltage T _J = 25 to 125°C	I _{RM} , Maximum peak reverse current		
	V	V	T _J = 25°C mA	at rated V _{RRM} T _J = 100°C mA	(t = I _{R(AV)}) T _J = 125°C mA
IRD3899	50	75	0.05	6.0	10.0†
IRD3900	100	150	0.05	6.0	10.0†
IRD3901	200	250	0.05	6.0	10.0†
IRD3902	300	350	0.05	6.0	10.0†
IRD3903	400	450	0.05	6.0	10.0†
IRD3909	50	75	0.08	10.0	15.0†
IRD3910	100	150	0.08	10.0	15.0†
IRD3911	200	250	0.08	10.0	15.0†
IRD3912	300	350	0.08	10.0	15.0†
IRD3913	400	450	0.08	10.0	15.0†

① Types listed are cathode case, for anode case, add "R" to code, i.e. IRD3899R etc.

Reverse recovery characteristics

	IRD3899 -IRD3903	IRD3909 -IRD3913	Units	Conditions
t _{rr} Maximum reverse recovery time	200	200	ns	T _J = 25°C, I _F = 1A to V _R = 30V -di _F /dt = 100A/μs
	350	350	ns	T _J = 25°C, -di _F /dt = 25A/μs I _{FM} = π x rated I _{F(AV)}
Q _{RR} Maximum reverse recovered charge	800	800	nC	T _J = 25°C, I _F = 1A to V _R = 30V -di _F /dt = 100A/μs
	1000	1000	nC	T _J = 25°C, -di _F /dt = 25A/μs I _{FM} = π x rated I _{F(AV)}

Forward conduction

	IRD3899 -IRD3903	IRD3909 -IRD3913	Units	Conditions
I _{F(AV)} Maximum average forward current	20	30	A	180° conduction, half sine wave, T _C = 100°C;
I _{F(RMS)} Maximum rms forward current	31	47	A	
I _{FSM} Maximum peak, one cycle non-repetitive forward current	240	285	A	t = 10ms Sinusoidal half wave, 100% V _{RRM} reapplied, initial T _J = 125°C
	250	300	A	t = 8.3ms
	285	340	A	t = 10ms Sinusoidal half wave, no voltage reapplied, initial T _J = 125°C
	295	355	A	t = 8.3ms
I ² t Maximum I ² t for fusing	285	410	A ² s	t = 10ms 100% V _{RRM} reapplied, initial T _J = 125°C
	260	375	A ² s	t = 8.3ms
	405	580	A ² s	t = 10ms No voltage reapplied, initial T _J = 125°C
	370	530	A ² s	t = 8.3ms
I ² √t Maximum I ² √t for, ind. device fusing ①	4050	5810	A ² √s	t = 0.1 - 10ms, no voltage reapplied
V _{FM} Maximum peak forward voltage	1.65	1.80	V	T _J = 25°C, I _{FM} = π x rated I _{F(AV)}

① I²t for time t_x = I²√t + √t_x.

THERMAL AND MECHANICAL SPECIFICATIONS

		IRD3899 -IRD3903	IRD3909 -IRD3913	Units	Conditions
T_J	Junction operating temperature range	-40 to 125		°C	
T_{stg}	Storage temperature range	-40 to 150		°C	
R_{thJC}	Maximum internal thermal resistance, junction to case	0.6	0.46	deg C/W	DC operation
R_{thCS}	Maximum thermal resistance case to heatsink	0.25		deg C/W	Mounting surface flat, smooth and greased
T	Mounting torque $\pm 10\%$	to nut	20 (27)	lbf.in	Lubricated threads (non-lubricated threads)
			0.23 (0.29)	kgf.m	
			2.2 (2.7)	Nm	
		to device	22	lbf.in	
			0.25	kgf.m	
			2.5	Nm	
wt	Approximate weight	25		g	
		0.88		oz	
Case style		DO-203AB (DO-5)			JEDEC

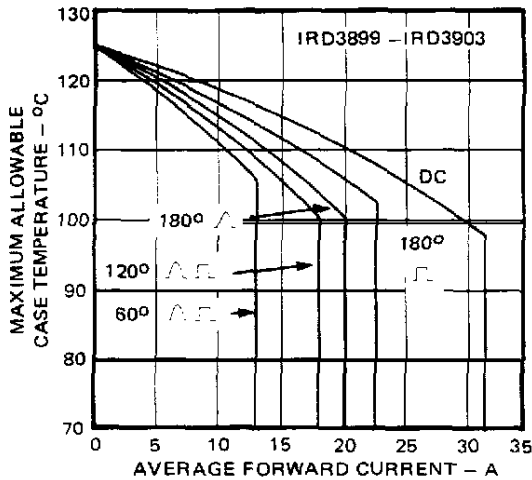

Fig. 1 – Average Forward Current Vs. Maximum Allowable Case Temperature, IRD3899 Series

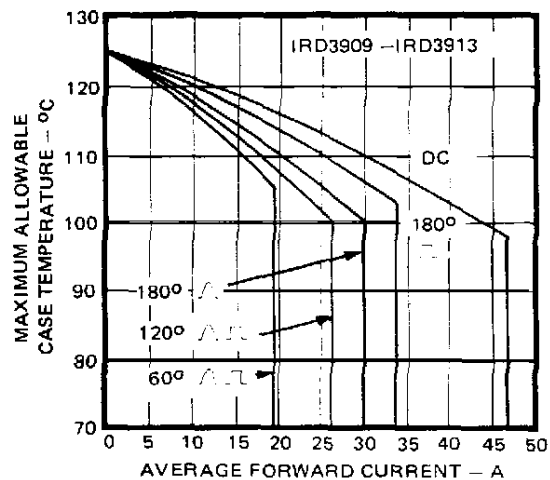
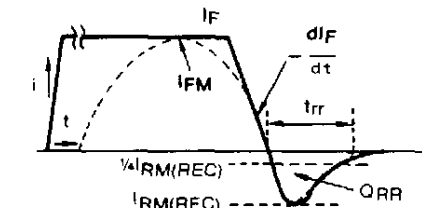

Fig. 2 – Average Forward Current Vs. Maximum Allowable Case Temperature, IRD3909 Series



- I_F, I_{FM} = Peak forward current prior to commutation
- $-dI_F/dt$ = Rate of fall of forward current
- $I_{RM(REC)}$ = Peak reverse recovery current
- t_{rr} = Reverse recovery time
- Q_{RR} = Reverse recovered charge

Fig. 3 – Reverse Recovery Time Test Waveform

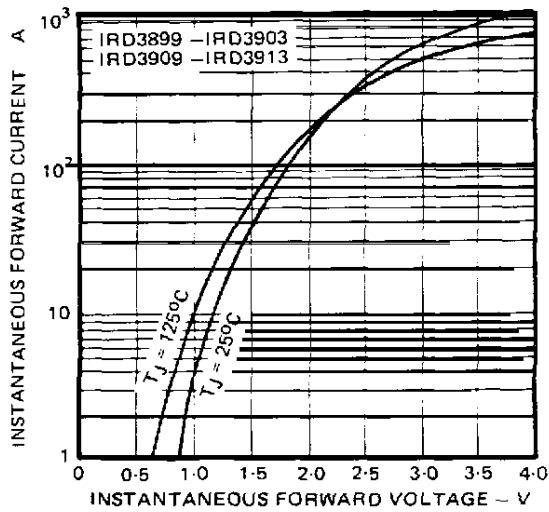

Fig. 4 – Maximum Forward Voltage Vs. Forward Current, Both Series

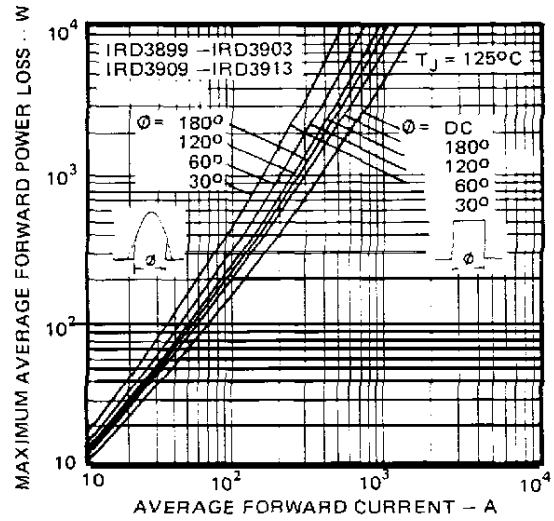

Fig. 5 – Maximum Forward Power Loss Vs. Average Forward Current, Both Series

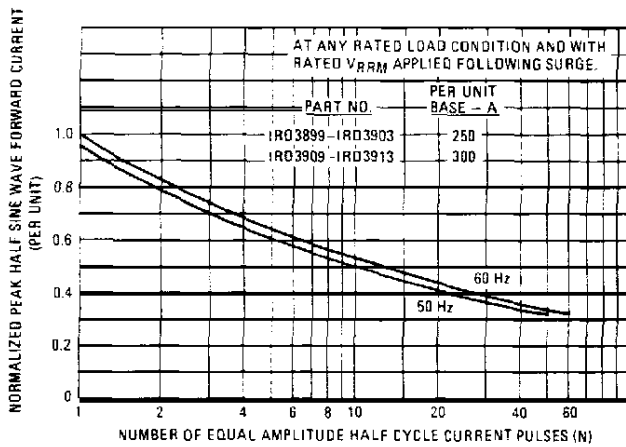

Fig. 6 – Maximum Non-Repetitive Surge Current Vs. Number of Current Pulses, Both Series

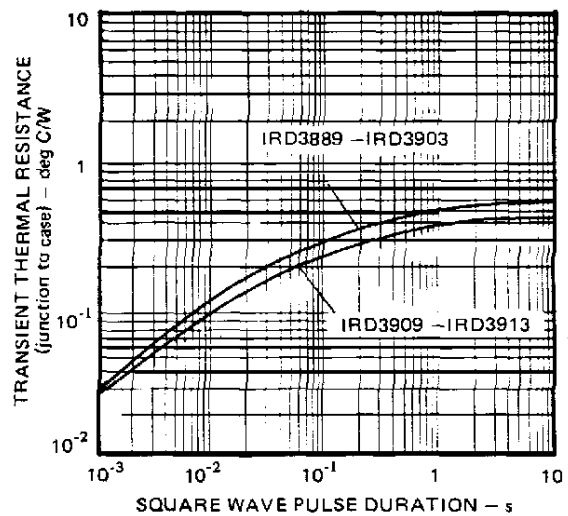

Fig. 7 – Maximum Transient Thermal Impedance, Junction-to-Case Vs. Pulse Duration, Both Series