

HiPerFRED

High Performance Fast Recovery Diode
Low Loss and Soft Recovery
Phase leg

Part number

DSEE55-24N1F

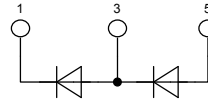

$$\begin{aligned} V_{RRM} &= 1200 \text{ V} \\ I_{FAV} &= 60 \text{ A} \\ t_{rr} &= 40 \text{ ns} \end{aligned}$$

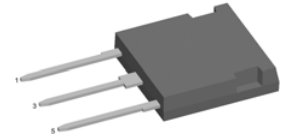

Backside: isolated

E72873

Features / Advantages:

- Planar passivated chips
- Very low leakage current
- Very short recovery time
- Improved thermal behaviour
- Very low I_{rm}-values
- Very soft recovery behaviour
- Avalanche voltage rated for reliable operation
- Soft reverse recovery for low EMI/RFI
- Low I_{rm} reduces:
 - Power dissipation within the diode
 - Turn-on loss in the commutating switch

Applications:

- Antiparallel diode for high frequency switching devices
- Antisaturation diode
- Snubber diode
- Free wheeling diode
- Rectifiers in switch mode power supplies (SMPS)
- Uninterruptible power supplies (UPS)

Package:

- Housing: i4-Pac
- DCB isolated backside
- Isolation Voltage 3000 V
- Epoxy meets UL 94V-0
- RoHS compliant

Ratings

Symbol	Definition	Conditions	Ratings			Unit
			min.	typ.	max.	
V_{RRM}	max. repetitive reverse voltage				1200	V
I_R	reverse current	$V_R = 1200 \text{ V}$			1	mA
		$V_R = 1200 \text{ V}$			4	mA
V_F	forward voltage	$I_F = 60 \text{ A}$			2.45	V
		$I_F = 120 \text{ A}$			2.90	V
		$I_F = 60 \text{ A}$			1.56	V
		$I_F = 120 \text{ A}$			2.00	V
I_{FAV}	average forward current	rectangular d = 0.5			60	A
V_{FO}	threshold voltage	} for power loss calculation only			0.97	V
r_F	slope resistance				6.8	mΩ
R_{thJC}	thermal resistance junction to case				0.60	K/W
T_{VJ}	virtual junction temperature		-55		175	°C
P_{tot}	total power dissipation				250	W
I_{FSM}	max. forward surge current	t = 10 ms (50 Hz), sine			800	A
I_{RM}	max. reverse recovery current				35	A
		$I_F = 60 \text{ A}; V_R = 600 \text{ V}$			60	A
					75	ns
t_{rr}	reverse recovery time	-di _F /dt = 600 A/μs			220	ns
					48	pF
C_J	junction capacitance	$V_R = 600 \text{ V}; f = 1 \text{ MHz}$			48	pF

Symbol	Definition	Conditions	Ratings			Unit
			min.	typ.	max.	
I_{RMS}	RMS current	per terminal			70	A
R_{thCH}	thermal resistance case to heatsink			0.20		K/W
T_{stg}	storage temperature		-55		150	°C
Weight				9		g
F_C	mounting force with clip		20		120	N
V_{ISOL}	isolation voltage	t = 1 second	3600			V
		t = 1 minute	3000			V
$d_{Spp/App}$	creepage striking distance on surface through air	terminal to terminal	5.5			mm
$d_{Spb/Apb}$	creepage striking distance on surface through air	terminal to backside	5.1			mm

Product Marking

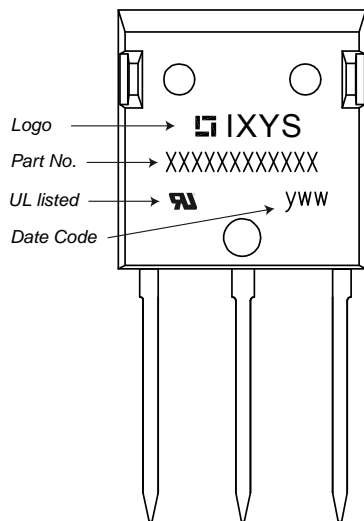

Ordering	Part Name	Marking on Product	Delivering Mode	Base Qty	Code Key
Standard	DSEE55-24N1F	DSEE55-24N1F	Tube	24	488739

Outlines i4-Pac

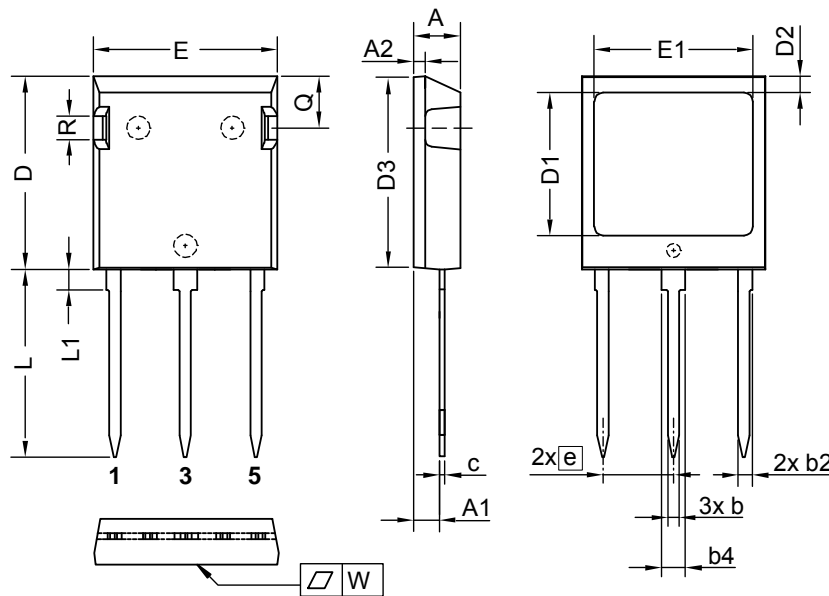

Dim.	Millimeter		Inches	
	min	max	min	max
A	4.83	5.21	0.190	0.205
A1	2.59	3.00	0.102	0.118
A2	1.17	2.16	0.046	0.085
b	1.14	1.40	0.045	0.055
b2	1.47	1.73	0.058	0.068
b4	2.54	2.79	0.100	0.110
c	0.51	0.74	0.020	0.029
D	20.80	21.34	0.819	0.840
D1	14.99	15.75	0.590	0.620
D2	1.65	2.03	0.065	0.080
D3	20.30	20.70	0.799	0.815
E	19.56	20.29	0.770	0.799
E1	16.76	17.53	0.660	0.690
e	7.62 BSC		0.300 BSC	
L	19.81	21.34	0.780	0.840
L1	2.11	2.59	0.083	0.102
Q	5.33	6.20	0.210	0.244
R	2.54	4.57	0.100	0.180
W	-	0.10	-	0.004

Die konvexe Form des Substrates ist typ. < 0.05 mm über der Kunststoffoberfläche der Bauteilunterseite
 The convexbow of substrate is typ. < 0.05 mm over plastic surface level of device bottom side

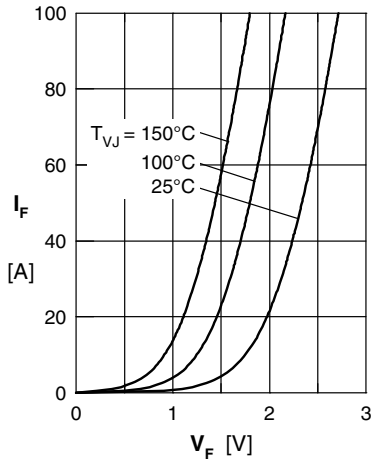

Fig. 1 Forward current I_F vs. V_F

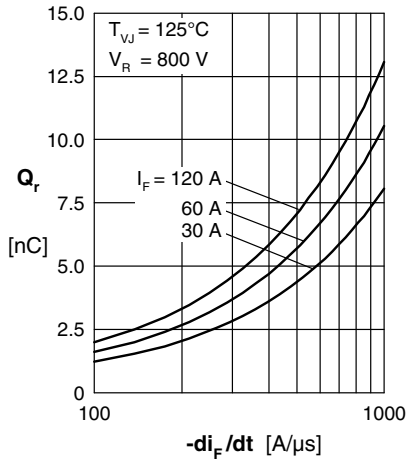

Fig. 2 Typ. reverse recovery charge Q_r versus $-di_F/dt$

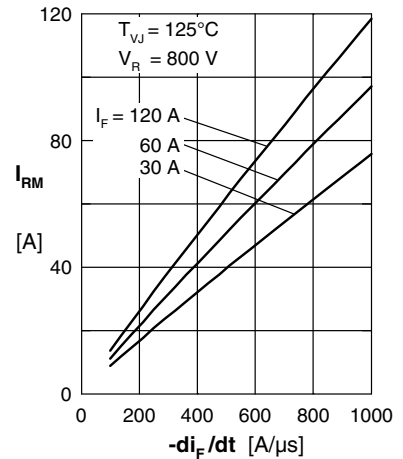

Fig. 3 Typ. peak reverse current I_{RM} versus $-di_F/dt$

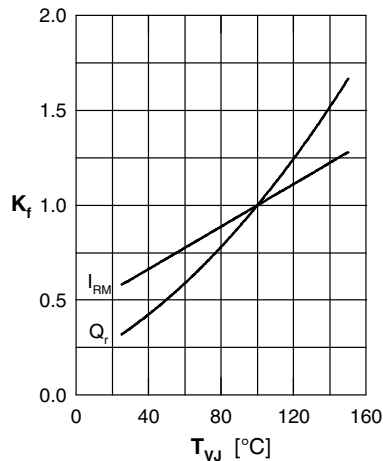

Fig. 4 Dynamic parameters Q_r , I_{RM} versus T_{VJ}

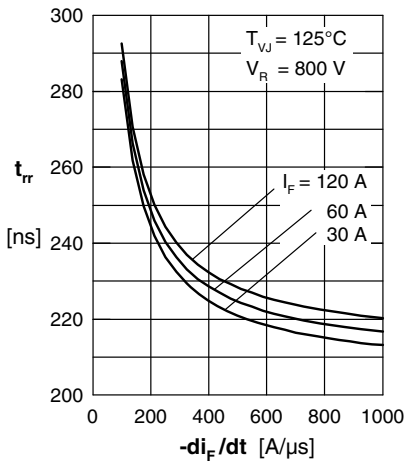

Fig. 5 Typ. recovery time t_{tr} versus $-di_F/dt$

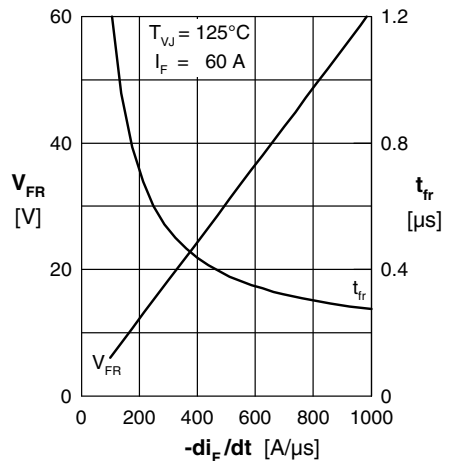

Fig. 6 Typ. peak forward voltage V_{FR} and typ. forward recovery time t_{fr} versus di_F/dt

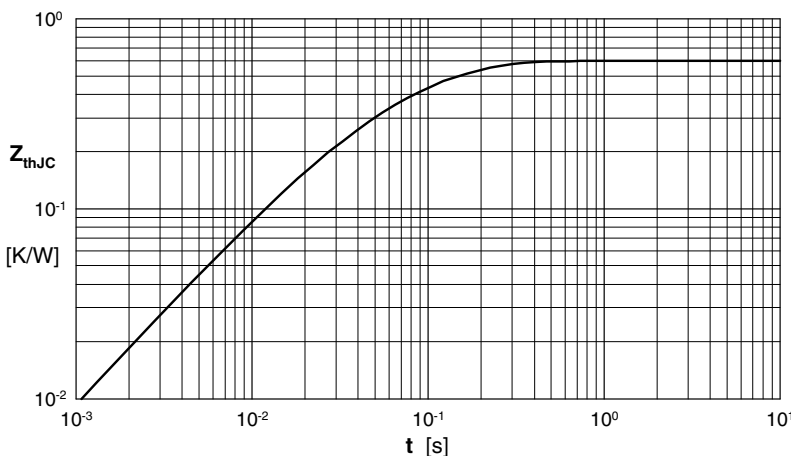

Fig. 7 Transient thermal resistance junction to case

Constants for Z_{thJC} calculation:

i	R_{thi} (K/W)	t_i (s)
1	0.212	0.0055
2	0.248	0.0092
3	0.063	0.0007
4	0.077	0.0391