

HiPerDynFRED™ Epitaxial Diode

ISOPLUS220™

Electrically Isolated Back Surface

$$I_{FAV} = 6 \text{ A}$$

$$V_{RRM} = 600 \text{ V}$$

$$t_{rr} = 20 \text{ ns}$$

$V_{RRM}^{①}$ V	V_{RRM} V	Type
600	300	DSEE 6-06CC

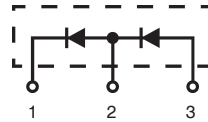

ISOPLUS 220
E153432

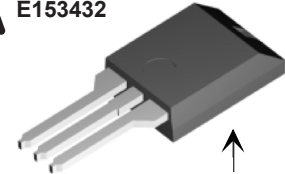

Isolated back surface*

Symbol	Conditions	Maximum Ratings	
I_{FRMS}		20	A
I_{FAVM}	$T_C = 150^\circ\text{C}$; rectangular, $d = 0.5$	6	A
E_{AS}	$T_{VJ} = 25^\circ\text{C}$; non-repetitive $I_{AS} = 0.8 \text{ A}$; $L = 180 \mu\text{H}$	0.1	mJ
I_{AR}	$V_A = 1.5 \cdot V_R$ typ.; $f = 10 \text{ kHz}$; repetitive	0.1	A
T_{VJ}		-40...+175	$^\circ\text{C}$
T_{VJM}		175	$^\circ\text{C}$
T_{stg}		-40...+150	$^\circ\text{C}$
P_{tot}	$T_C = 25^\circ\text{C}$	50	W
V_{ISOL}	50/60 Hz RMS; $I_{ISOL} \leq 1 \text{ mA}$	2500	V~
F_C	Mounting force	11...65 / 2.4...11	N / lb
Weight	typical	2	g

Features

- λ Silicon chip on Direct-Copper-Bond substrate
- High power dissipation
- Isolated mounting surface
- 2500V electrical isolation
- λ Low cathode to tab capacitance (<15pF)
- λ Planar passivated chips
- λ Very short recovery time
- λ Extremely low switching losses
- λ Low I_{RM} -values
- λ Soft recovery behaviour
- λ Epoxy meets UL 94V-0

Applications

- λ Antiparallel diode for high frequency switching devices
- λ Antisaturation diode
- λ Snubber diode
- λ Free wheeling diode in converters and motor control circuits
- λ Rectifiers in switch mode power supplies (SMPS)
- λ Inductive heating
- λ Uninterruptible power supplies (UPS)
- λ Ultrasonic cleaners and welders

Advantages

- λ Avalanche voltage rated for reliable operation
- λ Soft reverse recovery for low EMI/RFI
- λ Low I_{RM} reduces:
 - Power dissipation within the diode
 - Turn-on loss in the commutating switch

Symbol	Conditions	Characteristic Values	
		typ.	max.
$I_R^{①}$	$T_{VJ} = 25^\circ\text{C}$ $V_R = V_{RRM}$ $T_{VJ} = 150^\circ\text{C}$ $V_R = V_{RRM}$	25 0.2	μA mA
$V_F^{③}$	$I_F = 10 \text{ A}$; $T_{VJ} = 125^\circ\text{C}$ $T_{VJ} = 25^\circ\text{C}$	1.35 1.8	V V
R_{thJC} R_{thCH}		0.6	K/W K/W
t_{rr}	$I_F = 1 \text{ A}$; $-di/dt = 50 \text{ A}/\mu\text{s}$; $V_R = 30 \text{ V}$; $T_{VJ} = 25^\circ\text{C}$	20	ns
I_{RM}	$V_R = 100 \text{ V}$; $I_F = 10 \text{ A}$; $-di_F/dt = 100 \text{ A}/\mu\text{s}$ $T_{VJ} = 100^\circ\text{C}$	2	A

Notes: Data given for $T_{VJ} = 25^\circ\text{C}$ and per diode unless otherwise specified

- ① Diodes connected in series
- ② Pulse test: pulse Width = 5 ms, Duty Cycle < 2.0 %
- ③ Pulse test: pulse Width = 300 μs , Duty Cycle < 2.0 %

**Recommended replacement:
DSEE8-08CC**

IXYS reserves the right to change limits, test conditions and dimensions.

20080317a

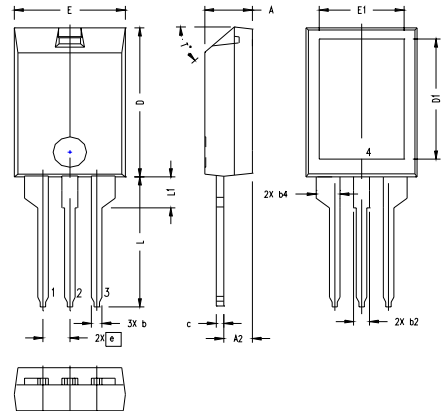
ISOPLUS220 Outline

SYM	INCHES		MILLIMETERS	
	MIN	MAX	MIN	MAX
A	.157	.197	4.00	5.00
A2	.098	.118	2.50	3.00
b	.035	.051	0.90	1.30
b2	.049	.065	1.25	1.65
b4	.093	.100	2.35	2.55
c	.028	.039	0.70	1.00
D	.591	.630	15.00	16.00
D1	.472	.512	12.00	13.00
E	.394	.433	10.00	11.00
E1	.295	.335	7.50	8.50
e	.100 BASIC		2.55 BASIC	
L	.512	.571	13.00	14.50
L1	.118	.138	3.00	3.50
T*			42.5*	47.5*

NOTE:

1. Bottom heatsink (Pin 4) is electrically isolated from Pin 1, 2 or 3.
2. Pin connections:
 - 1 - Cathode
 - 2 - Anode/Cathode
 - 3 - Anode