

Features

- Schottky Barrier Chip
- Guard Ring Die Construction for Transient Protection
- Low Power Loss, High Efficiency
- High Surge Capability
- High Current Capability and Low Forward Voltage Drop
- For Use in Low Voltage, High Frequency Inverters, Free Wheeling, and Polarity Protection Application
- **Lead Free Finish, RoHS Compliant (Note 3)**

Mechanical Data

- Case: TO-3P
- Case Material: Molded Plastic. UL Flammability Classification Rating 94V-0
- Moisture Sensitivity: Level 1 per J-STD-020C
- Terminals: Finish - Bright Tin. Plated Leads Solderable per MIL-STD-202, Method 208
- Polarity: As Marked on Body
- Ordering Information: See Last Page
- Marking: Type Number
- Weight: 5.6 grams (approximate)

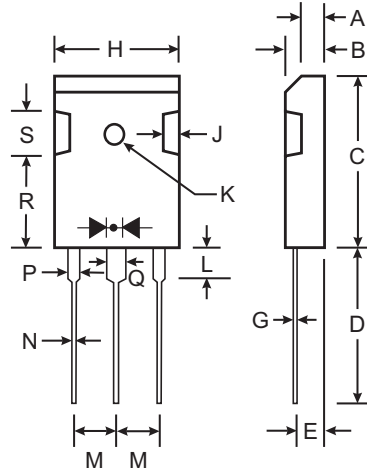

TO-3P		
Dim	Min	Max
A	1.88	2.08
B	4.68	5.36
C	20.63	22.38
D	18.5	21.5
E	2.1	2.4
G	0.51	0.76
H	15.38	16.25
J	1.90	2.70
K	2.9Ø	3.65Ø
L	3.78	4.50
M	5.2	5.7
N	0.89	1.53
P	1.82	2.46
Q	2.92	3.23
R	11.70	12.84
S	—	6.10
All Dimensions in mm		

Maximum Ratings and Electrical Characteristics @ T_A = 25°C unless otherwise specified

Single phase, half wave, 60Hz, resistive or inductive load.
For capacitive load, derate current by 20%.

Characteristic	Symbol	SBL 4030PT	SBL 4035PT	SBL 4040PT	SBL 4045PT	SBL 4050PT	SBL 4060PT	Unit
Peak Repetitive Reverse Voltage Working Peak Reverse Voltage DC Blocking Voltage	V _{RRM} V _{RWM} V _R	30	35	40	45	50	60	V
RMS Reverse Voltage	V _{R(RMS)}	21	24.5	28	31.5	35	42	V
Average Rectified Output Current @ T _C = 100°C (Note 1)	I _O	40						A
Non-Repetitive Peak Forward Surge Current 8.3ms Single half sine-wave superimposed on rated load (JEDEC Method)	I _{FSM}	375						A
Forward Voltage Drop @ I _F = 20A, T _C = 25°C	V _{FM}	0.58				0.70		V
Peak Reverse Current @ T _C = 25°C at Rated DC Blocking Voltage @ T _C = 100°C	I _{RM}				1.0 100			mA
Typical Total Capacitance (Note 2)	C _T	800						pF
Typical Thermal Resistance Junction to Case (Note 1)	R _{θJC}	1.4						°C/W
Operating Temperature Range	T _J	-55 to +125						°C
Storage Temperature Range	T _{STG}	-55 to +150						°C

- Notes:
1. Thermal resistance junction to case mounted on heatsink.
 2. Measured at 1.0MHz and applied reverse voltage of 4.0V DC.
 3. RoHS revision 13.2.2003. Glass and High Temperature Solder Exemptions Applied, see *EU Directive Annex Notes 5 and 7*.

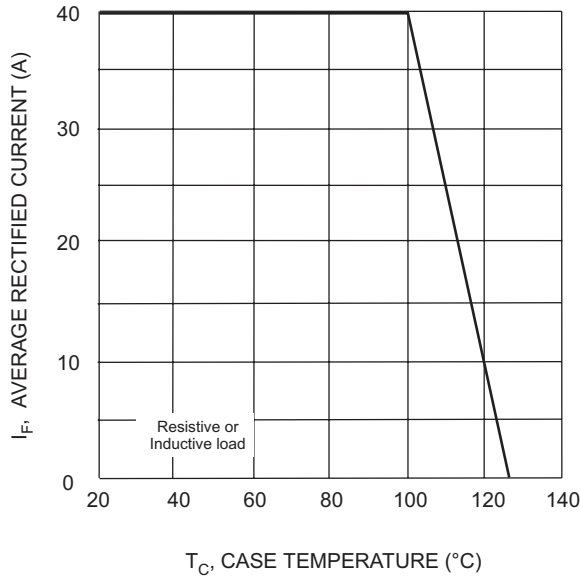

Fig. 1 Forward Current Derating Curve

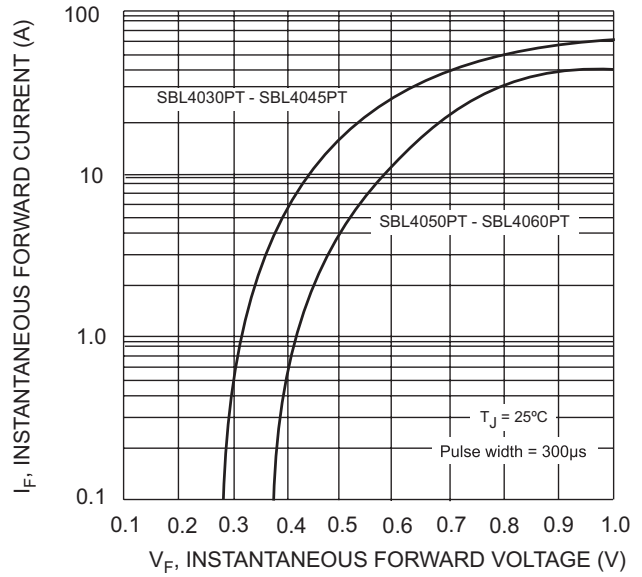

Fig. 2 Typical Forward Characteristics

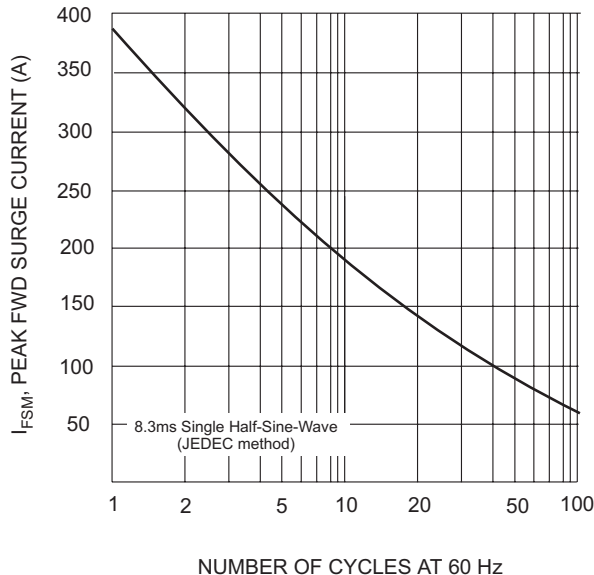

Fig. 3 Max Non-Repetitive Surge Current

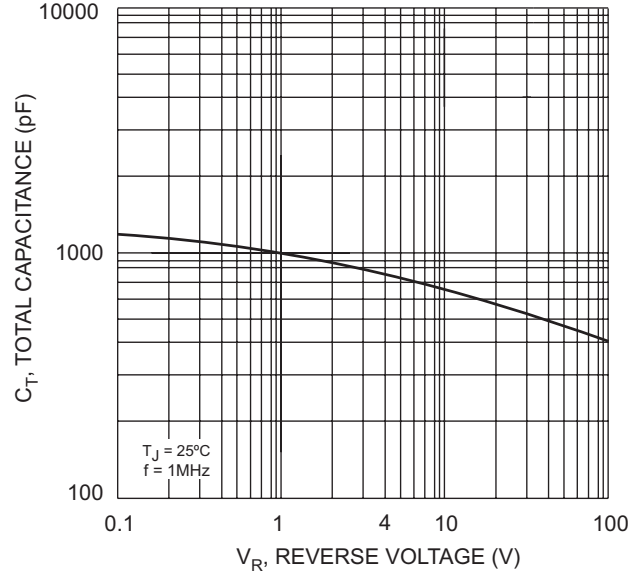

Fig. 4 Typical Total Capacitance per Element

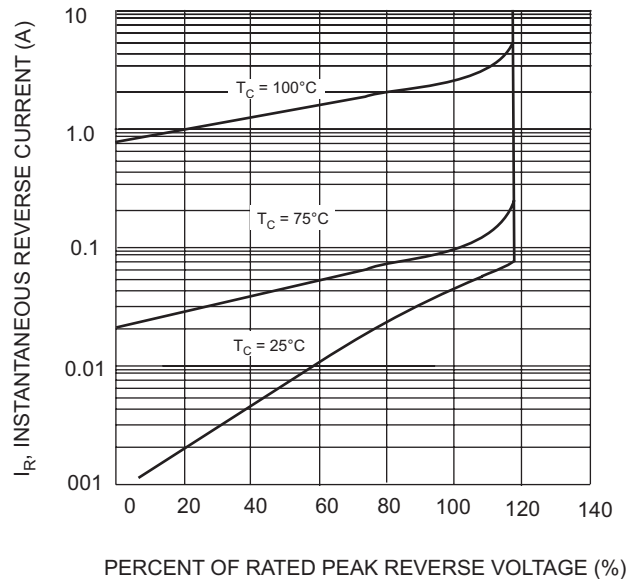

Fig. 5 Typical Reverse Characteristics

Ordering Information (Note 4)

Device	Packaging	Shipping
SBL4030PT	TO-3P	30/Tube
SBL4035PT	TO-3P	30/Tube
SBL4040PT	TO-3P	30/Tube
SBL4045PT	TO-3P	30/Tube
SBL4050PT	TO-3P	30/Tube
SBL4060PT	TO-3P	30/Tube

Notes: 4. For packaging details, visit our website at <http://www.diodes.com/datasheets/ap02008.pdf>