



### FEATURES

- Standard 3.2x2.5mm Surface Mount Footprint
- HCMOS/TTL Compatible
- **Fundamental and 3<sup>RD</sup> Overtone Crystals**
- Frequency Range 1.0 – 75 MHz
- Frequency Stability, ±50 ppm
- +1.8Vdc,+2.5Vdc,+2.8Vdc,+3.3Vdc Operation
- Operating Temperature to -10°C to +70°C
- Output Enable Standard
- Tape & Reel Packaging
- **RoHS/Green Compliant (6/6)**

### DESCRIPTION

The Model 632 is a ceramic packaged Clock oscillator offering reduced size and enhanced stability. The small size means it is perfect for any application. The enhanced stability means it is the perfect choice for today's communications applications that require tight frequency control.

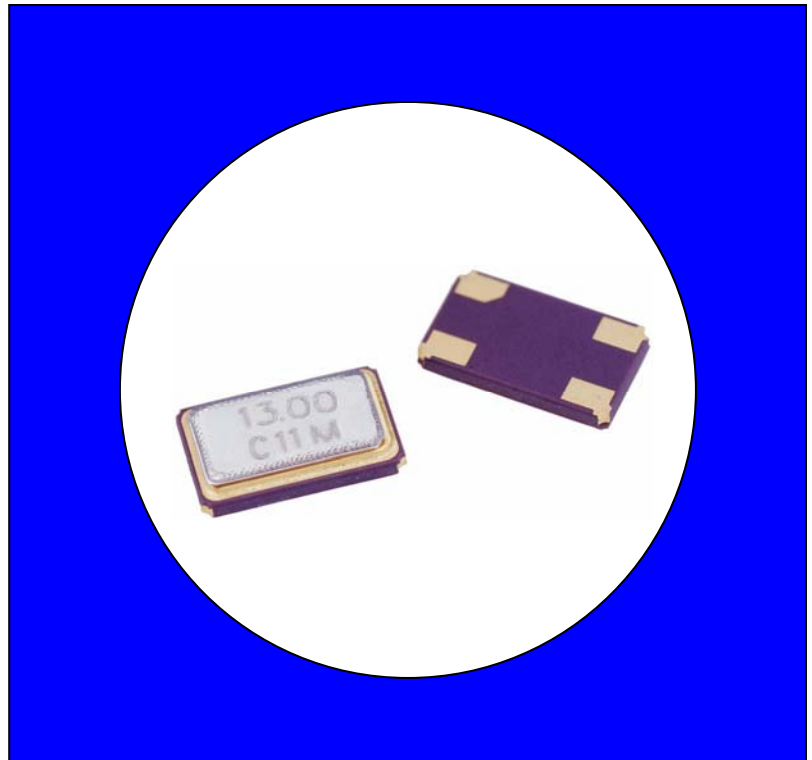

### ORDERING INFORMATION

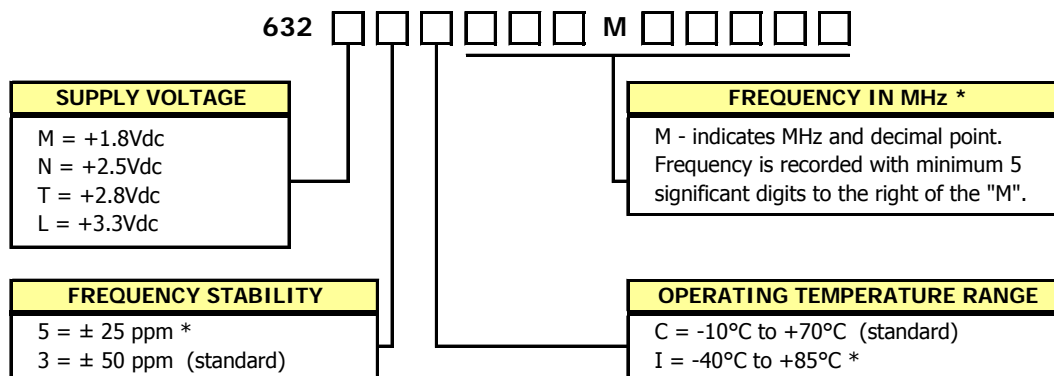

\* Contact factory for availability.

Example Part Number: 632L3C032M76800

## ELECTRICAL CHARACTERISTICS

	PARAMETER	SYMBOL	CONDITIONS	MIN	TYP	MAX	UNIT		
<b>Absolute Maximums</b>	Maximum Supply Voltage	$V_{CC}$	-	-0.5	-	4.0	V		
	Storage Temperature	$T_{STG}$	-	-55	-	125	°C		
	Frequency Range (See Note 1)	$f_O$	-	1.0	-	75	MHz		
	Frequency Stability (See Note 2 and Ordering Information)	$\Delta f/f_O$	-	-	-	50	± ppm		
	Aging	$\Delta f/f_O$	-	-	-	3	± ppm/yr		
	Operating Temperature Commercial Industrial	$T_A$	-	-10 -40	25	70 85	°C		
<b>Electrical and Waveform Parameters</b>	Supply Voltage Model 632M Model 632N Model 632T Model 632L	$V_{CC}$	± 10 %	1.62 2.25 2.52 2.97	1.8 2.5 2.8 3.3	1.98 2.75 3.08 3.63	V		
	Supply Current	$I_{CC}$	1.0 MHz to 20 MHz $C_L=15pF$	-	-	6	mA		
	Model 632M		20.1 MHz to 40 MHz $C_L=15pF$	-	-	7			
			40.1 MHz to 75 MHz $C_L=15pF$	-	-	10			
			1.0 MHz to 20 MHz $C_L=15pF$	-	-	8			
	Model 632N / Model 632T		20.1 MHz to 40 MHz $C_L=15pF$	-	-	10			
			40.1 MHz to 75 MHz $C_L=15pF$	-	-	10			
			1.0 MHz to 20 MHz $C_L=15pF$	-	-	10			
	Model 632L		20.1 MHz to 40 MHz $C_L=15pF$	-	-	15			
			40.1 MHz to 75 MHz $C_L=15pF$	-	-	15			
			Output Load	$C_L$					15
	Output Voltage Levels Logic '1' Level Logic '0' Level		$V_{OH}$ $V_{OL}$	CMOS Load CMOS Load	$90\%V_{CC}$ -	- -		- $10\%V_{CC}$	V
	Output Current Logic '1' Level Logic '0' Level		$I_{OH}$ $I_{OL}$	$V_{OH} = 90\%V_{CC}$ (1.8V, 2.5/2.8V, 3.3V) $V_{OL} = 10\%V_{CC}$ (1.8V, 2.5/2.8V, 3.3V)	- -	- -		-2, -4, -8 +2, +4, +8	mA
	Output Duty Cycle	SYM	@ 50% Level	45	-	55	%		
	Rise and Fall Time	$T_{R}, T_F$	@ 10% - 90% Levels, $C_L = 15 pF$			10	ns		
	Start Up Time	$T_S$	Application of $V_{CC}$	-	-	10	ms		
	Enable Function Enable Input Voltage Disable Input Voltage	$V_{IH}$ $V_{IL}$	Pin 1 Logic '1', Output Enabled Pin 1 Logic '0', Output Disabled	$0.7*V_{CC}$ -	- -	- $0.3*V_{CC}$	V		
	Enable Time	$T_{PLZ}$	Pin 1 Logic '1'	-	-	10	ms		
	Standby Current	$I_{ST}$	Pin 1 Logic '0', Output Disabled	-	-	10	uA		
	Period Jitter, Pk-Pk	-	-	-	-	100	ps		
	Period Jitter, RMS	-	-	-	-	25			
	Phase Jitter, RMS	-	Bandwidth 12 kHz - 20 MHz	-	< 2	-			

Notes:

- Contact factory for available frequencies.
- Inclusive of initial tolerance at time of shipment, changes in supply voltage, load, temperature and aging.

### CMOS/TTL OUTPUT WAVEFORM

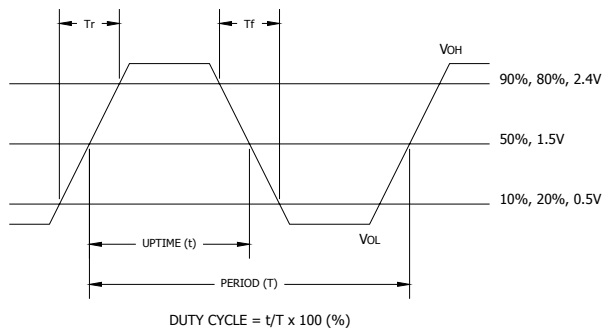

### ENABLE TRUTH TABLE

PIN 1	PIN 3
Logic '1'	Output
Open	Output
Logic '0'	High Imp.

### TEST CIRCUIT, CMOS LOAD

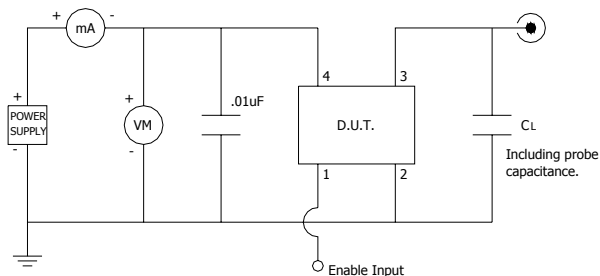

### D.U.T. PIN ASSIGNMENTS

PIN	SYMBOL	DESCRIPTION
1	EOH	Enable Input
2	GND	Circuit & Package Ground
3	Output	RF Output
4	V <sub>CC</sub>	Supply Voltage

## MECHANICAL SPECIFICATIONS

### PACKAGE DRAWING

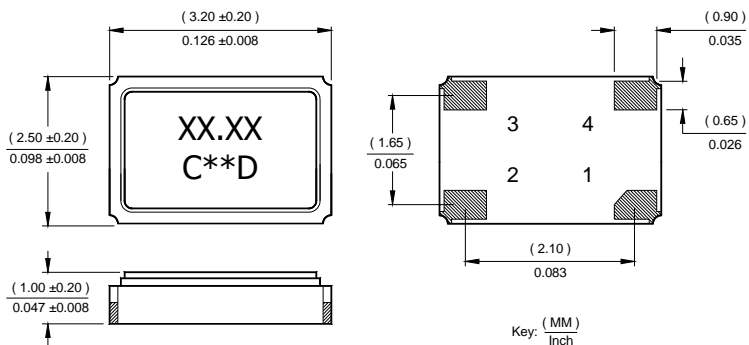

### MARKING INFORMATION

1. XX.XX – Frequency in MHz.
2. C – CTS and Pin 1 identifier.
3. \*\* – Manufacturing Site Code.
4. D – Manufactured Date Code. See Table I for codes.

### NOTES

1. Termination pads (e4), barrier-plating is nickel (Ni) with gold (Au) flash plate.
2. Reflow conditions per JEDEC J-STD-020.

### SUGGESTED SOLDER PAD GEOMETRY

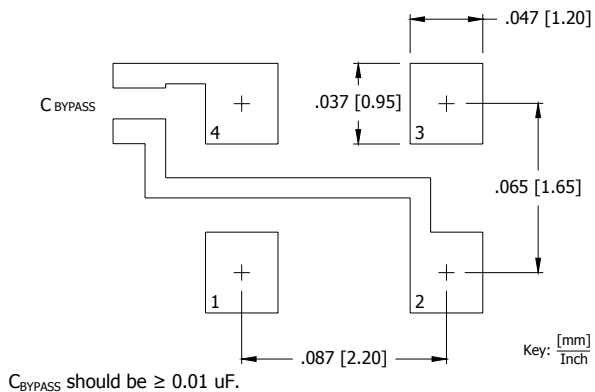
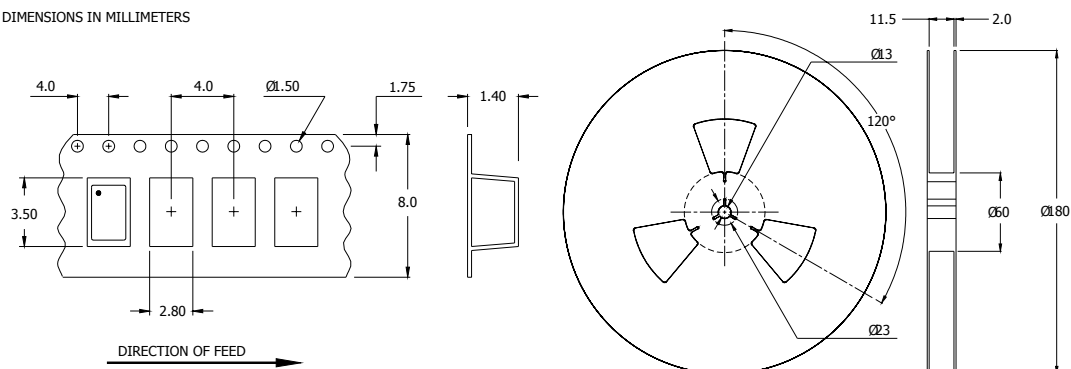

TABLE I

YEAR					MONTH											
					JAN	FEB	MAR	APR	MAY	JUN	JUL	AUG	SEP	OCT	NOV	DEC
2001	2005	2009	2013	2017	A	B	C	D	E	F	G	H	J	K	L	M
2002	2006	2010	2014	2018	N	P	Q	R	S	T	U	V	W	X	Y	Z
2003	2007	2011	2015	2019	a	b	c	d	e	f	g	h	j	k	l	m
2004	2008	2012	2016	2020	n	p	q	r	s	t	u	v	w	x	y	z

## TAPE AND REEL INFORMATION

DIMENSIONS IN MILLIMETERS



Device quantity is 3,000 pieces per 178mm reel minimum.

## ENVIRONMENTAL SPECIFICATIONS

Temperature Cycle:	400 cycles from $-55^{\circ}\text{C}$ to $+125^{\circ}\text{C}$ , 10 minute dwell at each temperature, 1 minute transfer time between temperatures.
Mechanical Shock:	1,500g's, 0.5mS duration, $\frac{1}{2}$ sinewave, 3 shocks each direction along 3 mutually perpendicular planes (18 total shocks).
Sinusoidal Vibration:	0.06 inches double amplitude, 10 to 55 Hz and 20g's, 55 to 2,000 Hz, 3 cycles each in 3 mutually perpendicular planes (9 times total).
Gross Leak:	No leak shall appear while immersed in an FC40 or equivalent liquid at $+125^{\circ}\text{C}$ for 20 seconds.
Fine Leak:	Mass spectrometer leak rates less than $2 \times 10^{-8}$ ATM cc/sec air equivalent.
Resistance to Solder Heat:	Product must survive 3 reflows of $+260^{\circ}\text{C}$ peak, 10 seconds maximum.
High Temperature Operating Bias:	2,000 hours at $+125^{\circ}\text{C}$ , maximum bias, disregarding frequency shift.
Frequency Aging:	1,000 hours at $+85^{\circ}\text{C}$ , full bias, less than $\pm 5$ ppm shift.
Moisture Sensitivity Level:	Level 1 per JEDEC J-STD-020.

## QUALITY AND RELIABILITY

Quality systems meet or exceed the requirements of ISO 9000:2000 standards.