

- ▶ 3.3 or 5.0V version
- ▶ 5 x 7 mm Footprint
- ▶ Low power consumption
- ▶ RoHS Compliant (Note 7 Exemption)

ECS-3951C/3953C

SMD CLOCK OSCILLATOR

ECS-3951C (5V) and ECS-3953C (3.3V) miniature SMD crystal controlled, low current clock oscillator in a ceramic SMD package.

OPERATING CONDITIONS / ELECTRICAL CHARACTERISTICS

PARAMETERS	CONDITIONS	ECS-3951C (+5V)			ECS-3953C (+3.3V)			UNITS
		MIN	TYP	MAX	MIN	TYP	MAX	
Frequency Range		1.000		80.000	1.000		125.000	MHz
Operating Temperature	Standard	0		+70	0		+70	°C
	Extended (N Option)	-40		+85	-40		+85	°C
Storage Temperature		-55		+125	-55		+125	°C
Supply Voltage		+4.5	+5.0	+5.5	+3.0	+3.3	+3.6	VDC
Frequency Stability *	Standard			± 100			± 100	ppm
	Option B			± 50			± 50	ppm
	Option C			± 25			± 25	ppm
Input Current	1.8 to 30.0 MHz			10			8	mA
	30.1 to 35.0 MHz			15			8	mA
	35.1 to 50.0 MHz			30			12	mA
	50.1 to 66.0 MHz			30			15	mA
	66.1 to 80.0 MHz			50			30	%
Output Symmetry	@ 50% VDD level			40/60			40/60	%
Rise and Fall Times	10% VDD to 90% level			10			15	ns
"0" level	VOL			10% * Vcc			10% * Vcc	VDC
"1" level	VOH	90% * Vcc			90% * Vcc			VDC
Output Load	HCMOS			15			15	pF
Startup time	1.8 to 36.0 MHz			5			5	ms
	36.1 to 80.0 MHz			10			10	ms
Output Current	VOL=0.5V/0.33V			4			4	mA
	VOL=4.5V/2.97V			-4			-4	mA
Enable/Disable Time				100			150	ns

DIMENSIONS (mm)

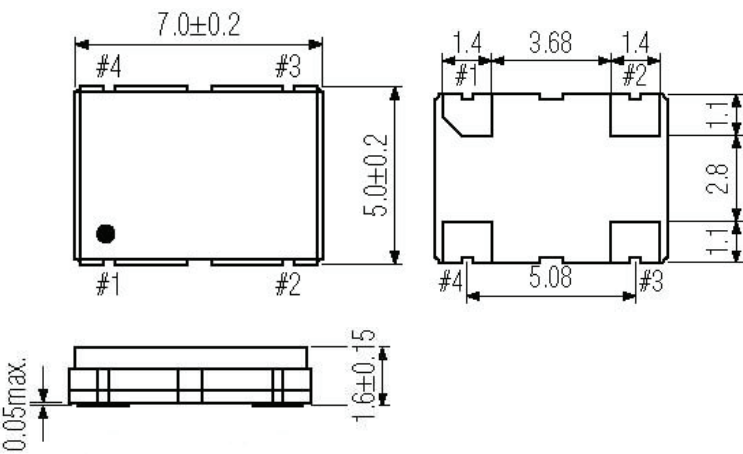

Figure 1) Top, Side and Bottom views

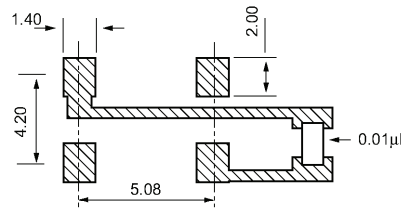

Figure 2) Suggested Land Pattern

Pin Connections

Pin #1	Tri-State **
Pin #2	Ground
Pin #3	Output
Pin #4	Vcc

Tri-State Control Voltage

Pad 1	Pad 3
Open	Oscillation
Vcc x 0.9 Min.	Oscillation
Vcc x 0.1 Max.	No Oscillation

* Note: Inclusive of 25°C tolerance, operating temperature, input voltage change, load change, shock and vibration.

** Note: Internal pullup resistor from pin 1 to 4 allows active output if pin 1 is left open.

PART NUMBERING GUIDE: Example ECS-3953C-500-B

ECS	- Series	- Frequency Abbreviation	- Stability	Temperature
	3951C = +5.0V 3953C = +3.3V	500 = 50.000 MHz See Frequency Abbreviations	Blank = ± 100 ppm B = ± 50 ppm C = ± 25 ppm	Blank = 0 ~ +70°C M = -20 ~ +70°C N = -40 ~ +85°C

ECS-3953C is also compatible with a supply voltage of +3.0V DC ±0.3V