

The ECX-3TA is a 2.0mm low profile ruggedized thermoplastic molded 32.768KHz SMD tuning fork crystal. This crystal is excellent for SMD applications with limited circuit board space requirements.

FEATURES

- Low profile 2.0mm maximum height
- Industry standard footprint
- Long term stability
- Excellent shock resistance
- Excellent environmental characteristics
- Tape & Reel (3,000 pcs)

PART NUMBERING GUIDE "EXAMPLE"

MANUFACTURER	FREQUENCY	LOAD CAPACITANCE	PACKAGE TYPE
ECS	- .327	- 12.5	- 24

OPERATING CONDITIONS/ELECTRICAL CHARACTERISTICS

PARAMETERS	ECX-3TA		UNITS
NOMINAL FREQUENCY	F ₀	32.768	KHz
LOAD CAPACITANCE	C _L	12.5 Standard (6.0 Optional)	pF
DRIVE LEVEL	D _L	1.0 max.	μW
CALIBRATION TOLERANCE	@ +25°C	±20	PPM
EQUIVALENT SERIES RESISTANCE	R ₁	50 max.	K Ω
TEMPERATURE COEFFICIENT		-0.040 PPM/°C ² max.	PPM/(ΔC°)
OPERATING TEMPERATURE RANGE	T _{OPR}	-10 ~ +60	°C
MAX. OPERATING TEMPERATURE RANGE		-40 ~ +85	°C
Q FACTOR	Q	50,000 min.	
TURNOVER TEMPERATURE	T ₀	+25 ± 5	°C
STORAGE TEMPERATURE RANGE	T _{STG}	-55 ~ +125	°C
INSULATION RESISTANCE	IR	500MΩ min./ DC 100V	MΩ
SHUNT CAPACITANCE	C ₀	2.0 typical	pF
MOTIONAL CAPACITANCE	C ₁	0.003 pF typical	pF
AGING (FIRST YEAR)	Δf/f ₀	±3 PPM max. @ +25°C	PPM

PACKAGE DIMENSIONS (mm)

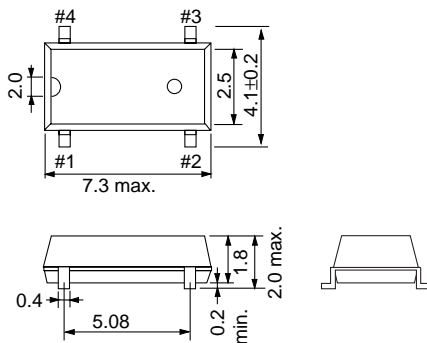

Figure 1) ECX-3TA - Top, Side and End views

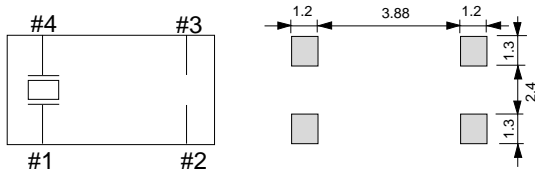
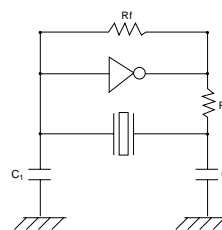

Figure 2) ECX-3TA - Land Pattern - Top view

RECOMMENDED OSCILLATION CIRCUIT



ELECTRICAL CHARACTERISTICS

IC: TC 4069P

Rf: 10MΩ

Rd: 330KΩ (As required)

C₁ = 22pF, C₂ = 22pF

V_{DD} = 3.0V

In this circuit, low drive level with a maximum of 1μW is recommended. If excessive drive is applied, irregular oscillation or quartz element fractures may occur.

PARABOLIC TEMPERATURE CURVE

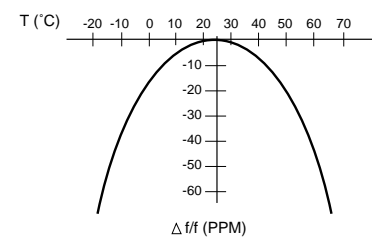

To determine frequency stability, use parabolic curvature. For example: What is the stability at 45°C?

- 1) Change in T (°C) = 45 - 25 = 20°C
- 2) Change in frequency = -0.04 PPM x (ΔT)²
= -0.04 PPM x (20)²
= -16.0 PPM