

Three Phase Rectifier Bridge with IGBT and Fast Recovery Diode for Braking System

Rectifier Diode	Fast Recovery Diode	IGBT
$V_{RRM} = 2200 \text{ V}$	$V_{CES} = 1800 \text{ V}$	$V_{CES} = 1700 \text{ V}$
$I_{DAVM100} = 150 \text{ A}$	$I_{C80} = 33 \text{ A}$	$I_{C80} = 80 \text{ A}$
$I_{FSM45} = 1000 \text{ A}$	$V_{F125} = 3.11 \text{ V}$	$V_{CE125} = 3.0 \text{ V}$

Preliminary data

Part name (Marking on product)

VUB135-22NO1

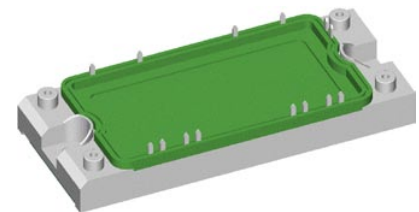
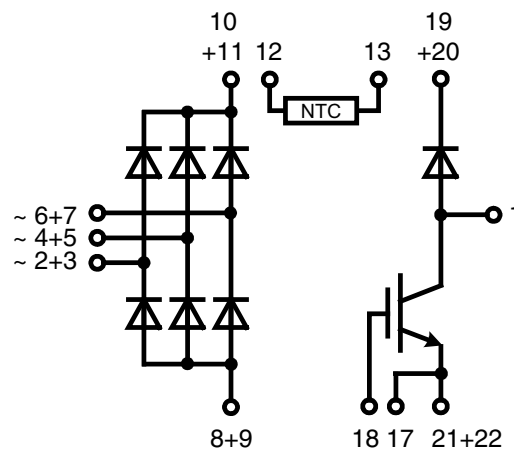

E72873

Pin configuration see outlines.

Features:

- Soldering connections for PCB mounting
- Convenient package outline
- Thermistor

Application:

- Drive Inverters with brake system

Package:

- 2 functions in one package
- Easy to mount with two screws
- Suitable for wave soldering
- High temperature and power cycling capability
- UL registered, E72873

IGBT

Symbol	Definitions	Conditions	Ratings			Unit	
			min.	typ.	max.		
V_{CES}	collector emitter voltage		$T_{VJ} = 25^{\circ}\text{C}$ to 150°C			V	
V_{GES}	max. DC gate voltage	continuous	-20		+20	V	
V_{GEM}	max. transient collector gate voltage	transient	-30		+30	V	
I_{C25}	collector current		$T_C = 25^{\circ}\text{C}$			A	
I_{C80}			$T_C = 80^{\circ}\text{C}$			A	
P_{tot}	total power dissipation		$T_C = 25^{\circ}\text{C}$			W	
$V_{CE(sat)}$	collector emitter saturation voltage	$I_C = 75\text{ A}; V_{GE} = 15\text{ V}$	$T_{VJ} = 25^{\circ}\text{C}$ $T_{VJ} = 125^{\circ}\text{C}$			V V	
$V_{GE(th)}$	gate emitter threshold voltage	$I_C = 3\text{ mA}; V_{GE} = V_{CE}$	$T_{VJ} = 25^{\circ}\text{C}$	5.2	6.4	V	
I_{CES}	collector emitter leakage current	$V_{CE} = V_{CES}; V_{GE} = 0\text{ V}$	$T_{VJ} = 25^{\circ}\text{C}$ $T_{VJ} = 125^{\circ}\text{C}$			0.6 tdb	
I_{GES}	gate emitter leakage current	$V_{CE} = 0\text{ V}; V_{GE} = \pm 20\text{ V}$				400	
C_{ies}	input capacitance	$V_{CE} = 25\text{ V}; V_{GE} = 0\text{ V}; f = 1\text{ MHz}$				6640	
$Q_{G(on)}$	total gate charge	$V_{CE} = 900\text{ V}; V_{GE} = 15\text{ V}; I_C = 75\text{ A}$				tdb	
$t_{d(on)}$	turn-on delay time	inductive load $V_{CE} = 900\text{ V}; I_C = 75\text{ A}$ $V_{GE} = \pm 15\text{ V}; R_G = 18\ \Omega$	$T_{VJ} = 125^{\circ}\text{C}$			220	ns
t_r	current rise time					100	ns
$t_{d(off)}$	turn-off delay time					880	ns
t_f	current fall time					200	ns
E_{on}	turn-on energy per pulse					30	mJ
E_{off}	turn-off energy per pulse					25	mJ
I_{CM}	reverse bias safe operating area	RBSOA; $V_{GE} = \pm 15\text{ V}; R_G = 18\ \Omega; L = 100\ \mu\text{H}$	150			A	
V_{CEK}		clamped inductive load; $T_{VJ} = 125^{\circ}\text{C}$	$\leq V_{CES} - L_S \cdot di/dt$			V	
t_{SC} (SCSOA)	short circuit safe operating area	$V_{CE} = 900\text{ V}; V_{GE} = \pm 15\text{ V};$ $R_G = 18\ \Omega; \text{non-repetitive}$	$T_{VJ} = 125^{\circ}\text{C}$			10	
R_{thJC}	thermal resistance junction to case	(per IGBT)				0.28	
R_{thCH}	thermal resistance case to heatsink					0.1	

Fast Recovery Diode

Symbol	Definitions	Conditions	Ratings			Unit	
			min.	typ.	max.		
V_{RRM}	max. repetitive reverse voltage		$T_{VJ} = 150^{\circ}\text{C}$			V	
I_{FAV}	average forward current		$T_C = 80^{\circ}\text{C}$			A	
V_{F0}	threshold voltage		$T_{VJ} = 150^{\circ}\text{C}$			V	
r_F	slope resistance	for power loss calculation only				17	
V_F	forward voltage	$I_F = 60\text{ A}$	$T_{VJ} = 25^{\circ}\text{C}$ $T_{VJ} = 125^{\circ}\text{C}$			V V	
I_R	reverse current	$V_R = V_{RRM}$	$T_{VJ} = 25^{\circ}\text{C}$ $T_{VJ} = 125^{\circ}\text{C}$			0.1 6	
I_{RM}	max. reverse recovery current	$V_R = 1200\text{ V}$ $di_F/dt = -400\text{ A}/\mu\text{s}$ $I_F = 60\text{ A}$	$T_{VJ} = 100^{\circ}\text{C}$			40	A
t_{rr}	reverse recovery time					tdb	ns
R_{thJC}	thermal resistance junction to case	(per diode)				0.65	
R_{thCH}	thermal resistance case to heatsink					0.25	

 $T_C = 25^{\circ}\text{C}$ unless otherwise stated

Rectifier Diode

Symbol	Conditions	Ratings			Unit
		min.	typ.	max.	
V_{RRM}	max. repetitive reverse voltage			2200	V
I_R	reverse current	$V_R = V_{RRM}$	$T_{VJ} = 25^\circ\text{C}$ $T_{VJ} = 125^\circ\text{C}$	0.1 2	mA mA
V_F	forward voltage	$I_F = 150\text{ A}$	$T_{VJ} = 25^\circ\text{C}$ $T_{VJ} = 125^\circ\text{C}$	1.85 1.96	V V
$I_{D(AV)M}$	max. average DC output current	rectangular; $d = 1/3$; bridge	$T_C = 100^\circ\text{C}$	150	A
V_{F0}	threshold voltage		$T_{VJ} = 150^\circ\text{C}$	0.87	V
r_F	slope resistance	for power loss calculation only		6.5	m Ω
R_{thJC}	thermal resistance junction to case		$T_{VJ} = 25^\circ\text{C}$	0.5	K/W
R_{thCH}	thermal resistance case to heatsink		$T_{VJ} = 25^\circ\text{C}$	0.1	K/W
T_{VJ}	virtual junction temperature		-40	125	$^\circ\text{C}$
P_{tot}	total power dissipation		$T_{VJ} = 25^\circ\text{C}$	250	W
I_{FSM}	max. forward surge current	$t = 10\text{ ms (50Hz)}$ $V_R = 0\text{ V}$	$T_{VJ} = 45^\circ\text{C}$ $T_{VJ} = 150^\circ\text{C}$	1000 870	A A
I^2t	value for fusing	$t = 10\text{ ms (50Hz)}$ $V_R = 0\text{ V}$	$T_{VJ} = 45^\circ\text{C}$ $T_{VJ} = 150^\circ\text{C}$	5000 3780	A A

Temperature Sensor NTC

Symbol	Definitions	Conditions	Ratings			Unit	
			min.	typ.	max.		
R_{25}	resistance		$T_C = 25^\circ\text{C}$	4.75	5.0	5.25	k Ω
$B_{25/85}$					3375		K

Module

Symbol	Definitions	Conditions	Ratings			Unit
			min.	typ.	max.	
T_{VJ}	operating temperature		-40		125	$^\circ\text{C}$
T_{VJM}	max. virtual junction temperature				150	$^\circ\text{C}$
T_{stg}	storage temperature		-40		125	$^\circ\text{C}$
V_{ISOL}	isolation voltage	$I_{ISOL} \leq 1\text{ mA}; 50/60\text{ Hz};$			3000 3600	V~ V~
M_d	mounting torque	(M5)	2.7		3.3	Nm
d_s	creep distance on surface		12.7			mm
d_A	strike distance through air		9.6			mm
a	maximum allowable acceleration		50			m/s ²
Weight				180		g

$T_C = 25^\circ\text{C}$ unless otherwise stated

Outline Drawing

Dimensions in mm (1 mm = 0.0394")

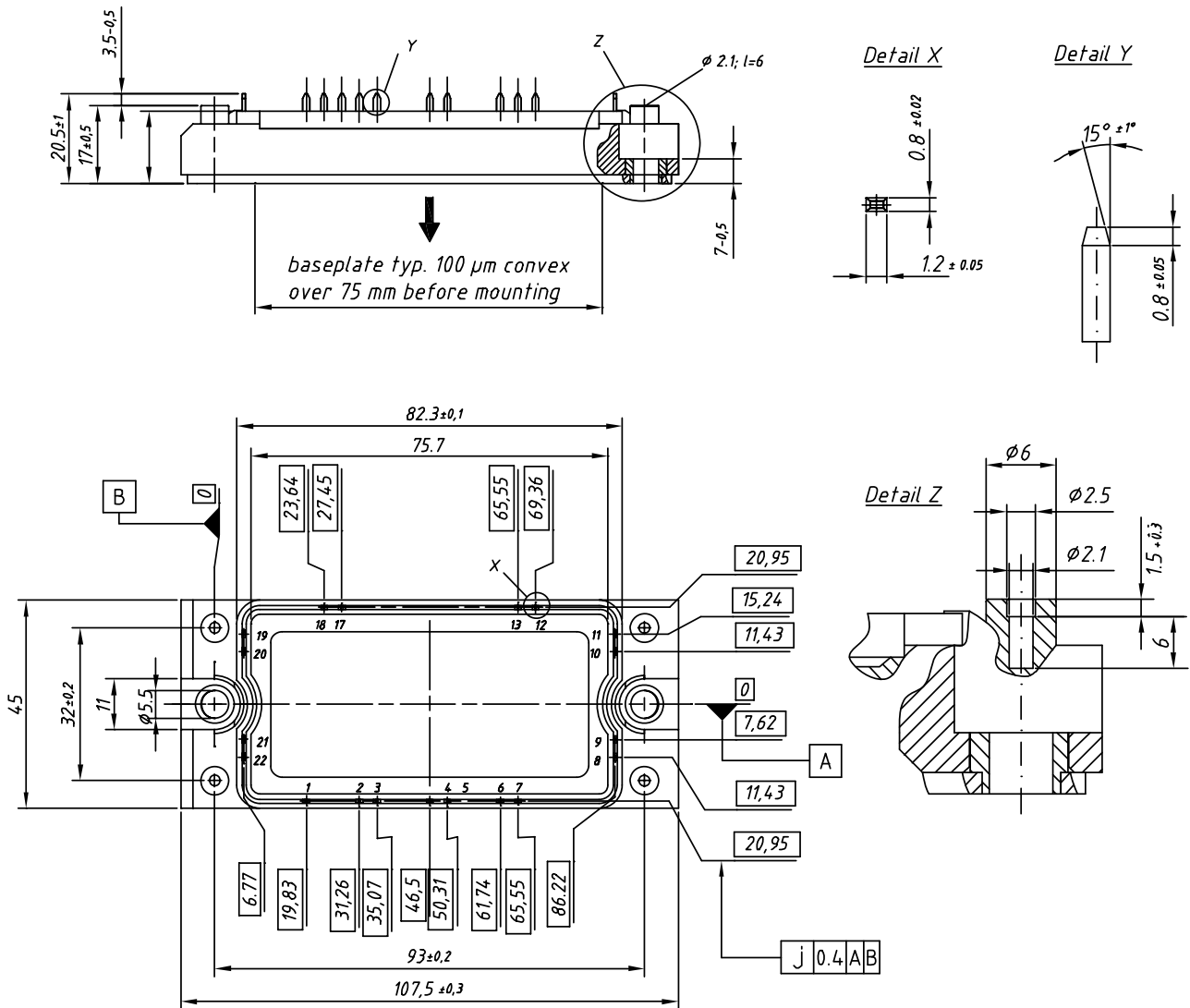

Product Marking

Ordering	Part Name	Marking on Product	Delivering Mode	Base Qty	Ordering Code
Standard	VUB 135-22NO1	VUB135-22NO1	Box	6	503948