

## Three Phase Rectifier Bridge

$$I_{dAV} = 20 \text{ A}$$

$$V_{RRM} = 800\text{-}1800 \text{ V}$$

$V_{RSM/DSM}$ V	$V_{RRM/DRM}$ V	Type
900	800	VUO 16-08NO1
1300	1200	VUO 16-12NO1
1500	1400	VUO 16-14NO1
1700	1600	VUO 16-16NO1
1900	1800	VUO 16-18NO1

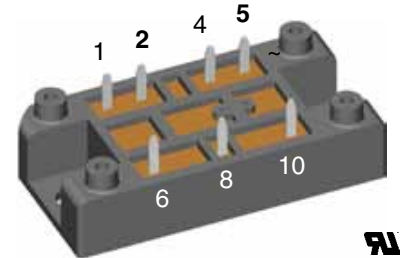
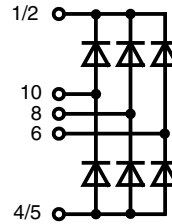

Symbol	Conditions	Maximum Ratings
$I_{dAV}$	$T_C = 90^\circ\text{C}$ , module	15 A
$I_{dAV}$	$T_A = 45^\circ\text{C}$ ( $R_{thKA} = 0.5 \text{ K/W}$ ), module	20 A
$I_{dAVM}$	module	20 A
$I_{FSM}$	$T_{VJ} = 45^\circ\text{C}$ ; $t = 10 \text{ ms}$ (50 Hz)	100 A
	$V_R = 0$ ; $t = 8.3 \text{ ms}$ (60 Hz)	106 A
	$T_{VJ} = T_{VJM}$ ; $t = 10 \text{ ms}$ (50 Hz)	85 A
	$V_R = 0$ ; $t = 8.3 \text{ ms}$ (60 Hz)	90 A
$I^2t$	$T_{VJ} = 45^\circ\text{C}$ ; $t = 10 \text{ ms}$ (50 Hz)	50 A <sup>2</sup> s
	$V_R = 0$ ; $t = 8.3 \text{ ms}$ (60 Hz)	47 A <sup>2</sup> s
	$T_{VJ} = T_{VJM}$ ; $t = 10 \text{ ms}$ (50 Hz)	36 A <sup>2</sup> s
	$V_R = 0$ ; $t = 8.3 \text{ ms}$ (60 Hz)	33 A <sup>2</sup> s
$T_{VJ}$		-40...+130 °C
$T_{VJM}$		130 °C
$T_{stg}$		-40...+125 °C
$V_{ISOL}$	50/60 Hz, RMS $t = 1 \text{ min}$	3000 V~
	$I_{ISOL} \leq 1 \text{ mA}$ $t = 1 \text{ s}$	3600 V~
$M_d$	Mounting torque (M5) (10-32 UNF)	2 - 2.5 Nm
		18 - 22 lb.in.
Weight	Typ.	35 g

### Features

- Package with DCB ceramic base plate
- Isolation voltage 3600 V~
- Planar passivated chips
- Blocking voltage up to 1800 V
- Low forward voltage drop
- UL registered E 72873

### Applications

- Supplies for DC power equipment
- Input rectifiers for PWM inverter
- Battery DC power supplies
- Field supply for DC motors

### Advantages

- Easy to mount with one screw
- Space and weight savings
- Improved temperature & power cycling

Symbol	Conditions	Characteristic Values
$I_R$	$V_R = V_{RRM}$ $T_{VJ} = 25^\circ\text{C}$ $T_{VJ} = T_{VJM}$	0.3 mA
		5.0 mA
$V_F$	$I_F = 7 \text{ A}$ $T_{VJ} = 25^\circ\text{C}$	1.15 V
$V_{T0}$	For power-loss calculations only	0.8 V
$r_t$		50 mΩ
$R_{thJH}$	per diode, 120° rect. per module, 120° rect.	4.5 K/W
		0.75 K/W
$d_s$	Creeping distance on surface	12.7 mm
$d_A$	Creepage distance in air	9.4 mm
$a$	Max. allowable acceleration	50 m/s <sup>2</sup>

Data according to IEC 60747 and refer to a single diode unless otherwise stated.

IXYS reserves the right to change limits, test conditions and dimensions.

20100503a

© IXYS All rights reserved

1 - 3

Dimensions in mm (1 mm = 0.0394")

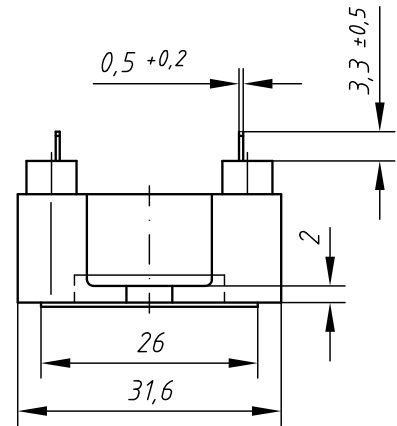
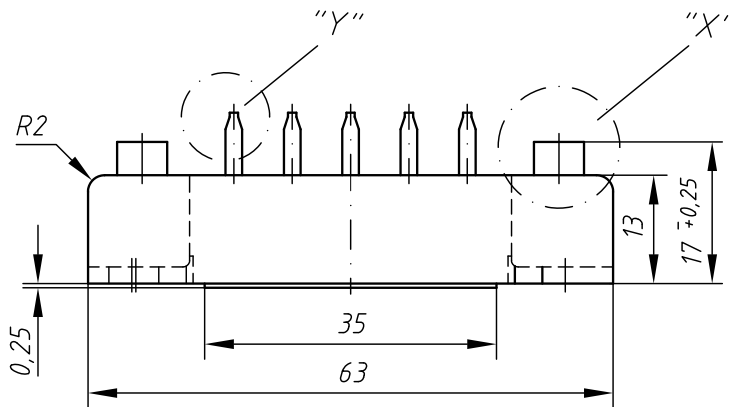

Detail "X" M 2:1

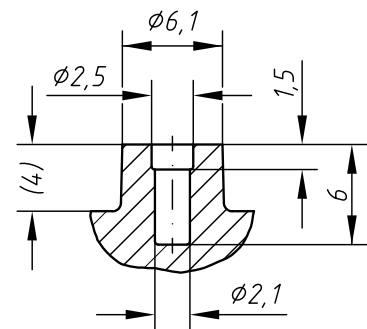

Detail "Y" M 5:1

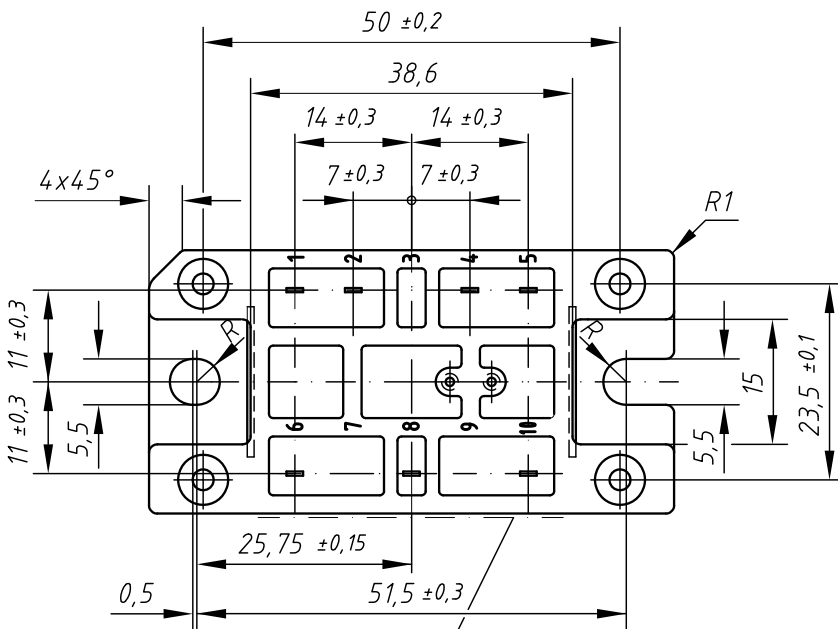
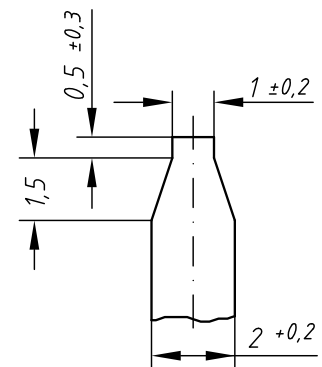

Aufdruck der Typenbezeichnung  
Marking on Product

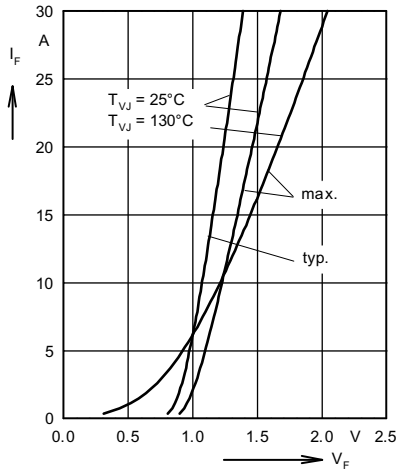

Fig. 1 Forward current versus voltage drop per diode

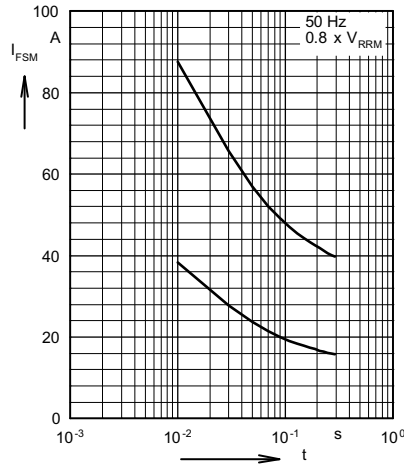

Fig. 2 Surge overload current per diode  
I<sub>FSM</sub>: Crest value. t: duration

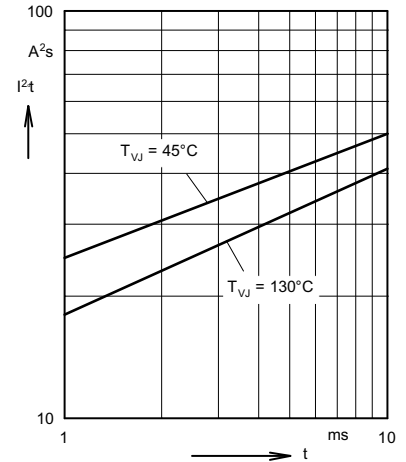

Fig. 3 I<sup>2</sup>t versus time  
(1-10 ms) per diode

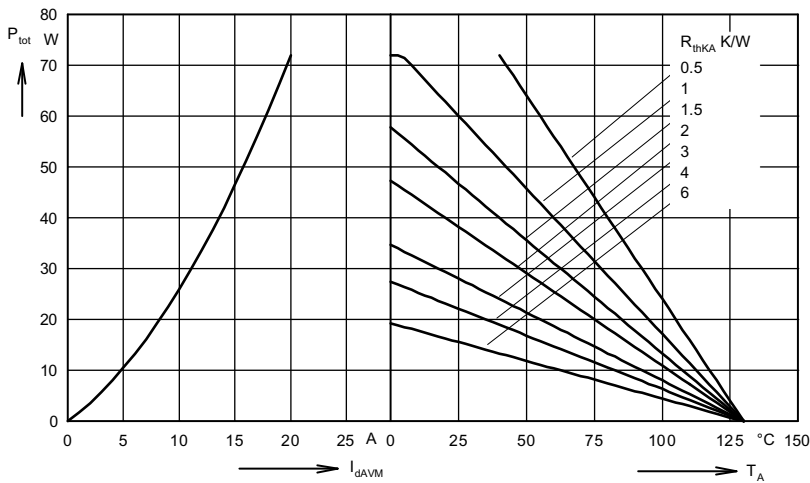

Fig. 4 Power dissipation versus direct output current and ambient temperature

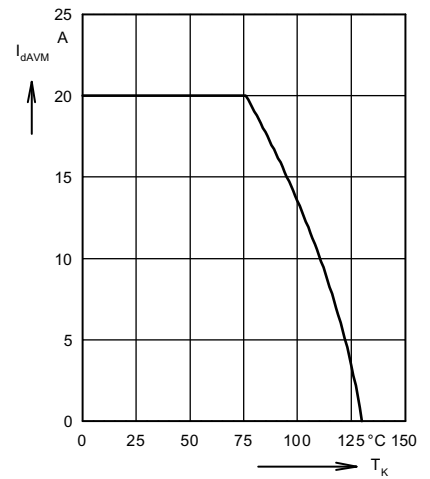

Fig. 5 Maximum forward current at case temperature

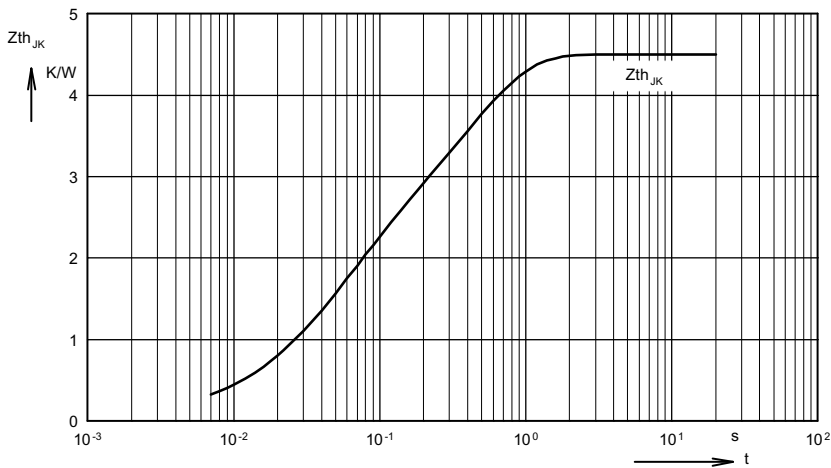

Fig. 6 Transient thermal impedance per diode

Constants for Z<sub>thJC</sub> calculation:

i	R <sub>thi</sub> (K/W)	t <sub>i</sub> (s)
1	0.005	0.008
2	0.1	0.02
3	1.835	0.05
4	2.55	0.4