

## Single Phase Rectifier Bridge

$I_{dAVM} = 54 \text{ A}$   
 $V_{RRM} = 800-1600 \text{ V}$

Preliminary data

$V_{RSM}$ V	$V_{RRM}$ V	Type
900	800	VBO 54-08NO7
1300	1200	VBO 54-12NO7
1700	1600	VBO 54-16NO7

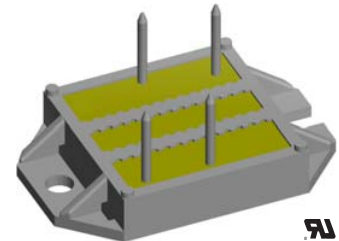
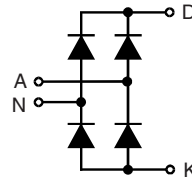

Symbol	Conditions	Maximum Ratings
$I_{dAV}^*$	$T_C = 100^\circ\text{C}$ , module	54 A
$I_{FSM}$	$T_{VJ} = 45^\circ\text{C}$ $V_R = 0$	t = 10 ms (50 Hz), sine 300 A t = 8.3 ms (60 Hz), sine 320 A
	$T_{VJ} = T_{VJM}$ $V_R = 0$	t = 10 ms (50 Hz), sine 260 A t = 8.3 ms (60 Hz), sine 280 A
$I^2t$	$T_{VJ} = 45^\circ\text{C}$ $V_R = 0$	t = 10 ms (50 Hz), sine 450 A <sup>2</sup> s t = 8.3 ms (60 Hz), sine 425 A <sup>2</sup> s
	$T_{VJ} = T_{VJM}$ $V_R = 0$	t = 10 ms (50 Hz), sine 340 A <sup>2</sup> s t = 8.3 ms (60 Hz), sine 325 A <sup>2</sup> s
$T_{VJ}$		-40...+150 °C
$T_{VJM}$		150 °C
$T_{stg}$		-40...+125 °C
$V_{ISOL}$	50/60 Hz, RMS t = 1 min	2500 V~
	$I_{ISOL} \leq 1 \text{ mA}$ t = 1 s	3000 V~
$M_d$	Mounting torque (M4)	1.5 - 2 Nm 14 - 18 lb.in.
Weight	typ.	18 g

### Features

- Package with DCB ceramic base plate
- Isolation voltage 3000 V~
- Planar passivated chips
- Low forward voltage drop
- Leads suitable for PC board soldering
- UL registered E 72873

### Applications

- Supplies for DC power equipment
- Input rectifiers for PWM inverter
- Battery DC power supplies
- Field supply for DC motors

### Advantages

- Easy to mount with two screws
- Space and weight savings
- Improved temperature and power cycling capability
- Small and light weight

Symbol	Test Conditions	Characteristic Values
$I_R$	$V_R = V_{RRM}$ $T_{VJ} = 25^\circ\text{C}$	$\leq 0.5 \text{ mA}$
	$V_R = V_{RRM}$ $T_{VJ} = T_{VJM}$	$\leq 3 \text{ mA}$
$V_F$	$I_F = 55 \text{ A}$ $T_{VJ} = 25^\circ\text{C}$	$\leq 1.46 \text{ V}$
$V_{TO}$	For power-loss calculations only	0.8 V
$r_T$		13 mΩ
$R_{thJC}$	per diode; DC current	1.1 K/W
	per module	0.28 K/W
$R_{thJH}$	per diode, DC current	1.6 K/W
	per module	0.4 K/W
$d_S$	Creeping distance on surface	11.2 mm
$d_A$	Creepage distance in air	9.7 mm
$a$	Max. allowable acceleration	50 m/s <sup>2</sup>

Data according to IEC 60747 refer to a single diode unless otherwise stated  
 \* for resistive load at bridge output.

IXYS reserves the right to change limits, test conditions and dimensions.

© 2010 IXYS All rights reserved

### Dimensions in mm (1 mm = 0.0394")

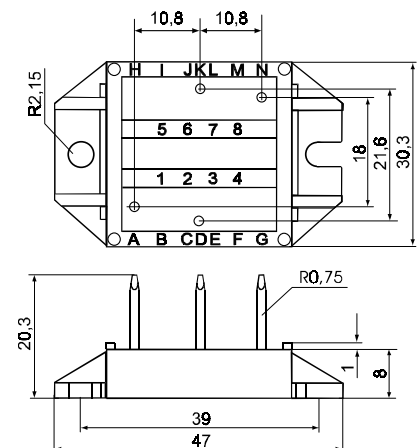

20100706a