

BR10/15/25/35/50A W -G SERIES

"-G" : RoHS Device

REVERSE VOLTAGE - 50 to 1000V

FORWARD CURRENT - 10/15/25/35/50A

FEATURES

- Surge overload -240~500 amperes peak
- Low forward voltage drop
- Mounting position: Any
- Electrically isolated base -2000 Volts
- Solderable 0.25" FASTON terminals
- Materials used carries U/L recognition

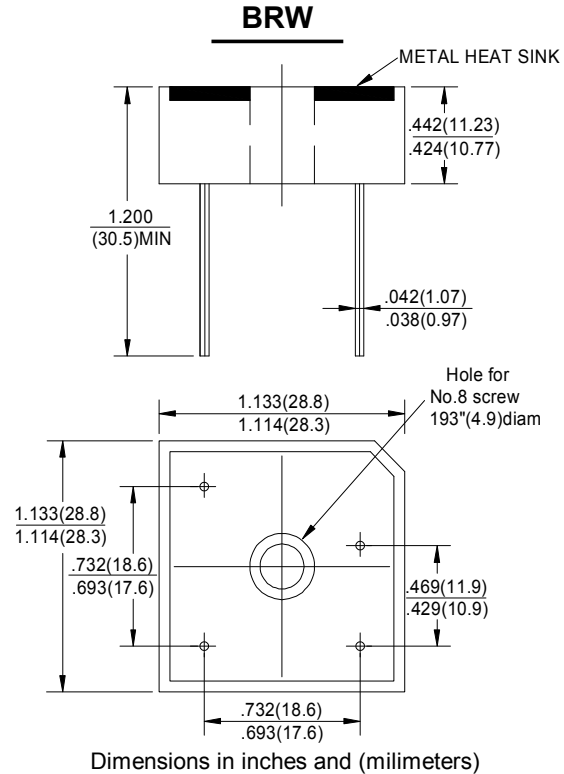

MAXIMUM RATINGS AND ELECTRICAL CHARACTERISTICS

Rating at 25°C ambient temperature unless otherwise specified.

Resistive or inductive load 60HZ.

For capacitive load current by 20%

CHARACTERISTICS	SYMBOL	BR-W	BR-W	BR-W	BR-W	BR-W	BR-W	BR-W	UNIT			
		10005	1001	1002	1004	1006	1008	1010				
		15005	1501	1502	1504	1506	1508	1510				
		25005	2501	2502	2504	2506	2508	2510				
		35005	3501	3502	3504	3506	3508	3510				
		50005	5001	5002	5004	5006	5008	5010				
		Maximum Recurrent Peak Reverse Voltage	VRRM	50	100	200	400	600		800	1000	V
Maximum RMS Bridge Input Voltage	VRMS	35	70	140	280	420	560	700	V			
Maximum Average Forward Rectified Output Current at @Tc=55°C	I(AV)	BR-W 10	10	BR-W 15	15	BR-W 25	25	BR-W 35	35	BR-W 50	50	A
Peak Forward Surge Current 8.3ms Single Half Sine-Wave Super Imposed on Rated Load	IFSM	BR-W 10	240	BR-W 15	300	BR-W 25	400	BR-W 35	400	BR-W 50	500	A
Maximum Forward Voltage Drop Per Element at 5.0/7.5/12.5/17.5/25.0A Peak	VF	1.1									V	
Maximum Reverse Current at Rated DC Blocking Voltage Per Element @TA=25°C	IR	10.0									µA	
Operating Temperature Rang	TJ	-55 to +125									°C	
Storage Temperature Rang	TSTG	-55 to +125									°C	

RATINGS AND CHARACTERISTIC CURVES BR10/15/25/35/50A W -G SERIES

FIG.1-MAXIMUM FORWARD SURGE CURRENT

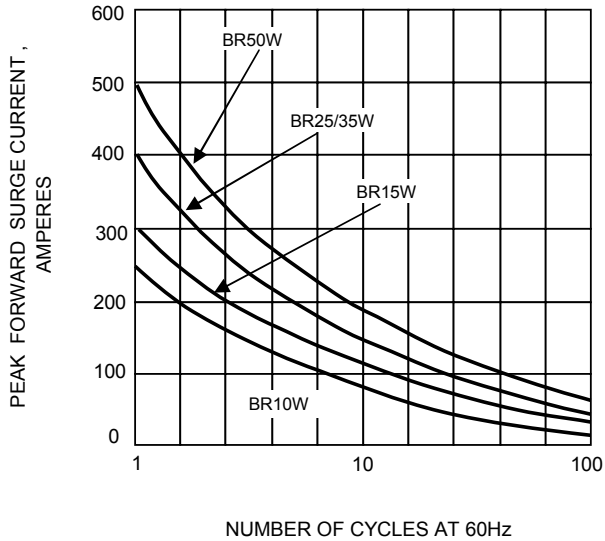

FIG.2- DERATING CURVE OUTPUT RECTIFIED CURRENT

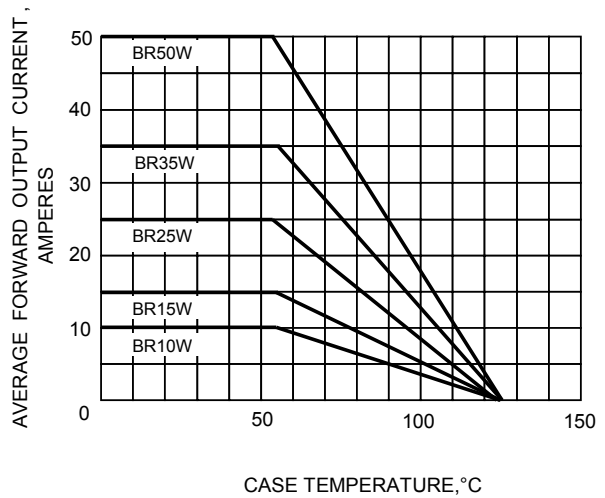

FIG.3-TYPICAL FORWARD CHARACTERISTICS

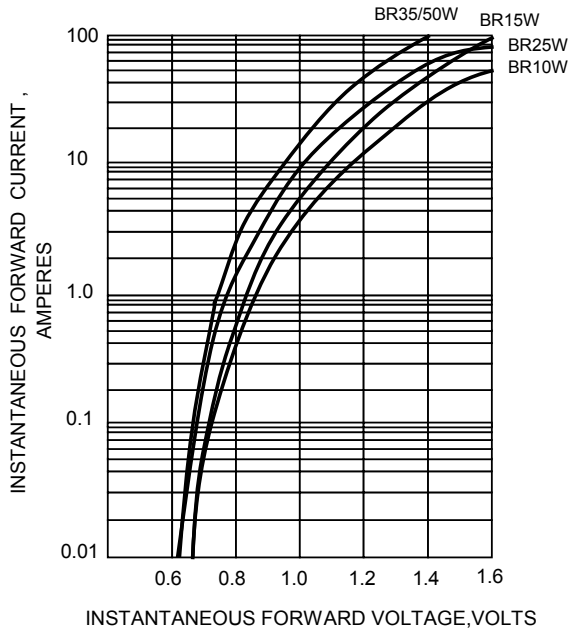

FIG.4-TYPICAL REVERSE CHARACTERISTICS

