

SOURCE CONTROL DRAWING
OFFICIAL SPECIFICATION

Item :	HC/49US (AT49) SMD Low Profile Crystal
EMBER CORP P/N	565-2400-001
ABRACON P/N :	ABLS-24.000MHZ-D-R60-1-W-T

<p>Customer's Approval Please return this copy as a certification of your approval.</p> <p>Approved by:</p> <hr/> <p>Date :</p>
--

PROPRIETARY NOTICE
These documents, and the contained information herein, are proprietary and are not to be reproduced, used or disclosed to others for manufacture or for any other purpose, except as specifically authorized, in writing, by Abracon Corporation.

ABRACON CORPORATION
Headquarters
30332 Esperanza, Rancho Santa Margarita
California, The USA.
Tel : 949-546-8000
Fax: 949-546-8001

Internal Use Only	
	500205
500041	500450
500210	500710

WARNING: ESD SENSITIVE PRODUCT

REVISION HISTORY				
REV.	ECO	DESCRIPTION	DATE	APP'D
-	-	Initial release	1/22/2007	LL

				TITLE ABLS-24.000MHZ-D-R60-1-W-T HC/49US (AT49) SMD Low Profile Crystal		
PREP. LL	DATE 1/22/2007	ENGR. HU	DATE 1/22/2007	SCALE None	DRAWING NO. 452489	REV. -
CKD CB	DATE 1/22/2007	APP'D JE	DATE 1/22/2007	PAGE OF 1 7		

1.0 SCOPE

This specification describes a 24.000MHz HC/49US SMD crystal.

2.0 ELECTRICAL SPECIFICATIONS

Abrakon P/N:	ABLS-24.000MHZ-D-R60-1-W-T
Frequency:	24.000MHz
Operation mode:	Fundamental, AT-strip
Operating temperature:	- 40°C to + 85°C
Storage temperature:	- 55°C to + 125° C
Frequency tolerance:	± 10 ppm max.
Frequency stability over the operating temperature (Ref to +25° C):	± 25 ppm max.
Equivalent series resistance (max.):	60ohms max.
Shunt capacitance C0:	7.0pF max
Load capacitance CL:	18.0+/-1.0pF
Drive level:	1mW max., 100uW Typical
Aging @ 25° C per a year :	± 5 ppm max. / year
Insulation resistance:	500 Mohms min. at 100 Vdc ± 15 Vdc

3.0 SPECIAL REQUIREMENT

This product is **RoHS compliant** and **Pb-free**.

4.0 Marking

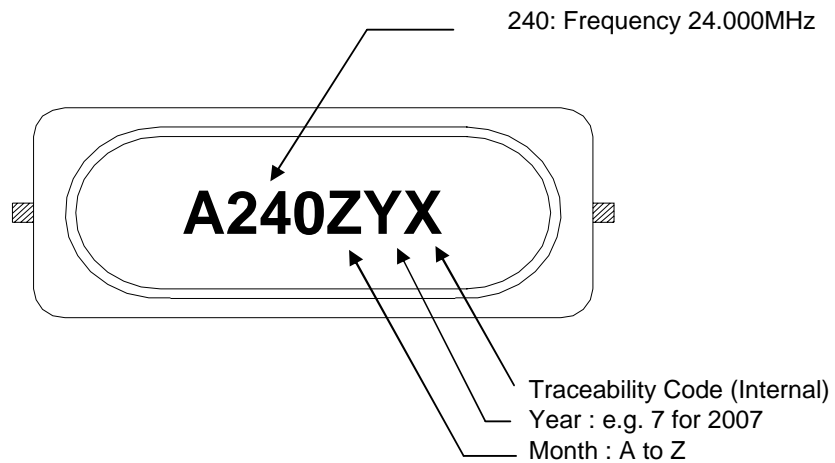

Month	Code
January	A
February	B
March	C
April	D
May	E
June	F
July	G
August	H
September	I
October	J
November	K
December	L

4.1 Marking Method : Laser Marking

5.0 Outline dimensions

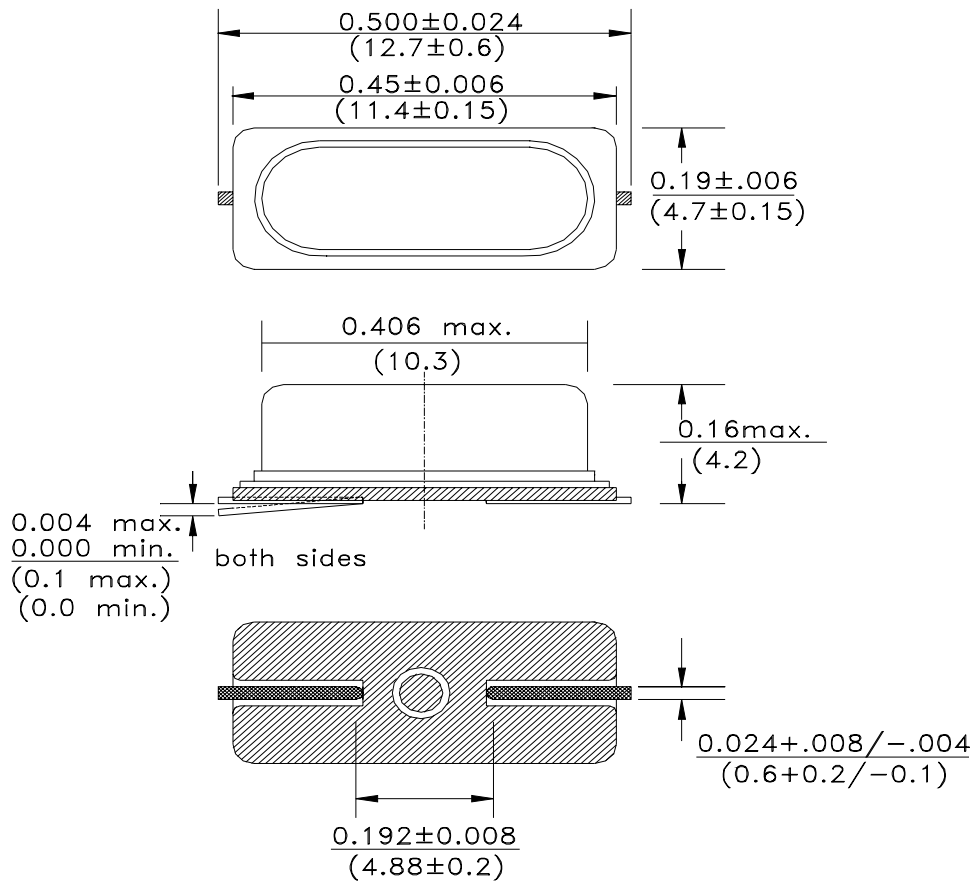

Recommended land pattern

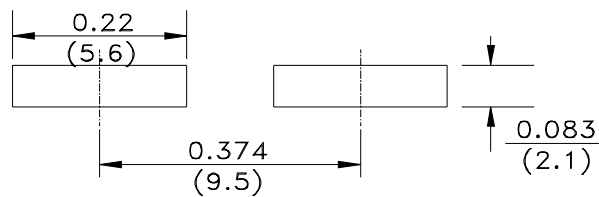

Dimension : Inches (mm)

TOLERANCES:

UNLESS OTHERWISE SPECIFIED: .X: ± 0.1 (0.25) .XX: ± 0.01 (0.025) .XXX: ± 0.005 (0.013)

6.0 Reliability Test

No.	Test Items	Test Conditions
1	Temperature Cycling:	The component shall remain within the electrical specification (± 5 ppm max) after 3 cycles of high and low temperature testing (-40°C to +85°C) for 2 hours max.
2	Thermal Shock:	The component shall remain within the electrical specification after exposure at extreme temperature -40°C to +85°C for 5 minutes for 3 cycles.
3	Vibration:	The component shall remain within the electrical specification after loaded vibration at 10Hz to 55Hz, amplitude 1.5mm, within 1 minute for 2 hours minimum on each axis (X,Y,Z).
4	Drop Test:	The component shall remain within the electrical specifications after a natural drop (3X) on a hard wooden board at 75 cm.
5	Humidity:	The component shall remain within the electrical specifications after being kept at a condition of ambient temperature +85°C, 85% RH for 96 hours minimum.
6	Fine Leak Test:	Expose samples to 60PSIG Helium gas for 2 hours. Max leak rate 2×10^{-8} atmcc/s.
7	Gross Leak Test:	Submerge samples in 100% De-ionized water or Perfluorocarbon at 85°C for at least 1 minute. Check for bubbles.
8	Solderability:	Solderability of terminals shall be kept at more than 95% after dipped in solder flux at $230^\circ\text{C} \pm 5^\circ\text{C}$ for 5 seconds.
9	Lead Bend	The component shall withstand maximum bend of 90° reference to base for 2 bends. Solder tinning must be 4 microns thick minimum.

6.1 Reflow Profile

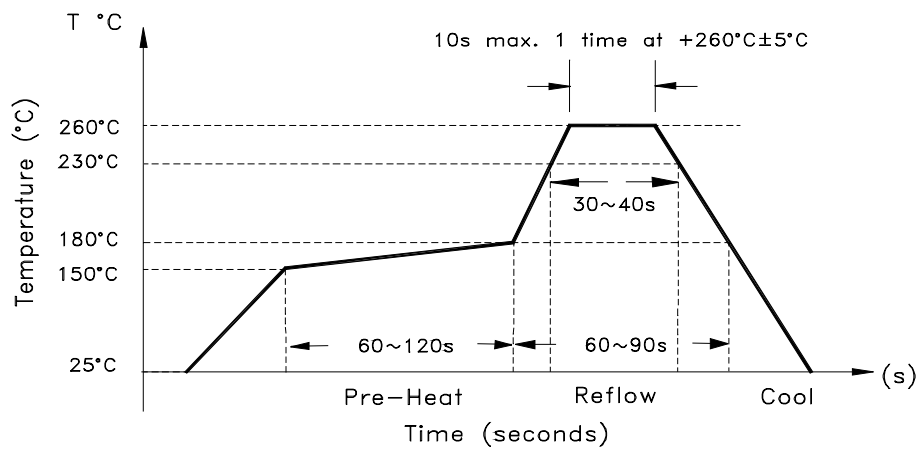

7.0 PACKING

T= tape and reel (1,000pcs/reel)

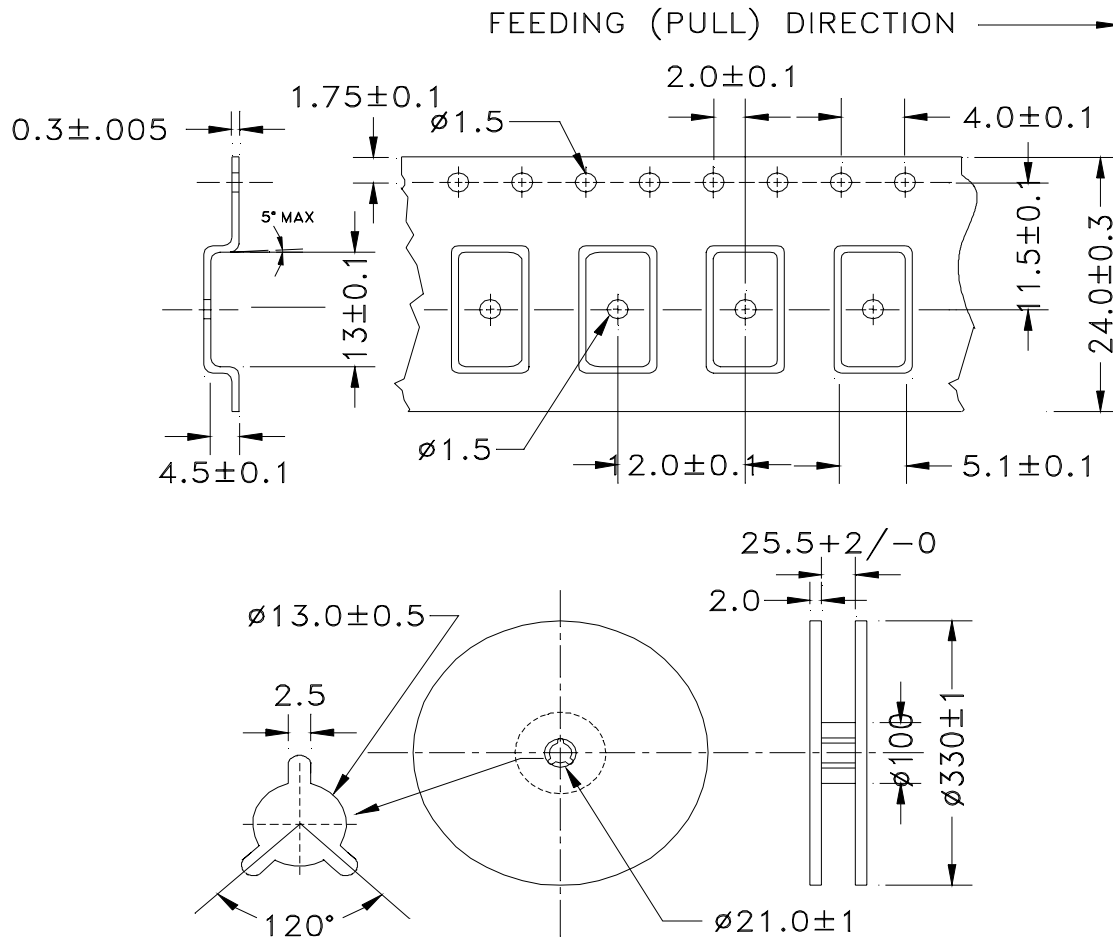

Dimension : Inches (mm)

TOLERANCES:

UNLESS OTHERWISE SPECIFIED: .X: ± 0.1 (0.25) .XX: ± 0.01 (0.025) .XXX: ± 0.005 (0.013)

8.0 Note

- (1) The parts are manufactured in accordance with this specification. If other conditions and specifications which are required for this specification, please contact ABRACON for more information.
- (2) ABRACON will supply the parts in accordance with this specification unless we receive a written request to modify prior to an order placement.
- (3) In no case shall ABRACON be liable for any product failure from in appropriate handling or operation of the item beyond the scope of this specification.
- (4) When changing your production process, please notify ABRACON immediately.
- (5) If you intend to use the product for listed application which may possibly cause to loss of life or assets, please notify ABRACON in advance.
(For example, Medical, Aerospace, Aeronautic equipment, Safety control equipment as well as safety related.)
- (6) All specifications and Marking will be subject to change without notice.
- (7) See ABRACON website (www.abracon.com) for additional Terms and Conditions.