

SURFACE MOUNT VOIDLESS-HERMETICALLY-SEALED ULTRA FAST RECOVERY GLASS RECTIFIERS

DESCRIPTION

This "Ultrafast Recovery" surface mount rectifier diode series is military qualified to MIL-PRF-19500/477 and is ideal for high-reliability applications where a failure cannot be tolerated. These industry-recognized 2.5 Amp rated rectifiers for working peak reverse voltages from 50 to 150 volts are hermetically sealed with voidless-glass construction using an internal "Category I" metallurgical bond. They are also available in axial-leaded package configurations for thru-hole mounting (see separate data sheet for 1N5802 thru 1N5806). Microsemi also offers numerous other rectifier products to meet higher and lower current ratings with various recovery time speed requirements including standard, fast and ultrafast device types in both through-hole and surface mount packages.

APPEARANCE

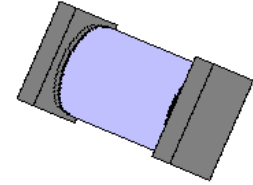

Package "A" or D-5A

IMPORTANT: For the most current data, consult MICROSEMI's website: <http://www.microsemi.com>

FEATURES

- Surface mount package series equivalent to the JEDEC registered 1N5802 to 1N5806 series
- Voidless hermetically sealed glass package
- Extremely robust construction
- Triple-layer passivation
- Internal "Category I" Metallurgical bonds
- JAN, JANTX, JANTXV, and JANS available per MIL-PRF-19500/477
- Axial-leaded equivalents available (see 1N5802 thru 1N5806)

APPLICATIONS / BENEFITS

- Ultrafast recovery 2.5 Amp rectifier series 50 to 150 V
- Military and other high-reliability applications
- Switching power supplies or other applications requiring extremely fast switching & low forward loss
- High forward surge current capability
- Low thermal resistance
- Controlled avalanche with peak reverse power capability
- Inherently radiation hard as described in Microsemi MicroNote 050

MAXIMUM RATINGS

- Junction Temperature: -65°C to +175°C
- Storage Temperature: -65°C to +175°C
- Average Rectified Forward Current (I_O): 2.5 A @ $T_{EC} = 75^\circ\text{C}$
- Thermal Resistance: 13 °C/W junction to end cap
- Thermal Impedance: 4.5°C/W @ 10 ms heating time
- Forward Surge Current: 35 Amps @ 8.3 ms half-sine
- Capacitance: 25 pF @ $V_R = 10$ Volts, $f = 1$ MHz
- Solder temperature: 260°C for 10 s (maximum)

MECHANICAL AND PACKAGING

- CASE: Hermetically sealed voidless hard glass with Tungsten slugs
- TERMINALS: End caps are Copper with Tin/Lead (Sn/Pb) finish. Note: Previous inventory had solid Silver end caps with Tin/Lead (Sn/Pb) finish.
- MARKING and POLARITY: Cathode band only
- Tape & Reel option: Standard per EIA-481-B
- Weight: 193 mg
- See package dimensions and recommended pad layout on last page

ELECTRICAL CHARACTERISTICS

TYPE	WORKING PEAK REVERSE VOLTAGE	BREAKDOWN VOLTAGE (MIN.) @ 100µA	AVERAGE RECTIFIED CURRENT I_{O1} @ $T_{EC}=+75^\circ\text{C}$ (NOTE 1)	AVERAGE RECTIFIED CURRENT I_{O2} @ $T_A=+55^\circ\text{C}$ (Note 2)	MAXIMUM FORWARD VOLTAGE @ 1 A (8.3 ms pulse) V_F		REVERSE CURRENT (MAX) @ V_{RWM} I_R	SURGE CURRENT (MAX) I_{FSM} (NOTE 3)	REVERSE RECOVERY TIME (MAX) (NOTE 4) t_{rr}	
	V_{RWM}	V_{BR}	AMPS	AMPS	VOLTS		µA	AMPS	ns	
	VOLTS	VOLTS			25°C	100°C	25°C	125°C		
1N5802US	50	55	2.5	1.0	0.875	0.800	1	175	35	25
1N5803US	75	80	2.5	1.0			1	175	35	25
1N5804US	100	110	2.5	1.0	0.875	0.800	1	175	35	25
1N5805US	125	135	2.5	1.0			1	175	35	25
1N5806US	150	160	2.5	1.0	0.875	0.800	1	175	35	25

NOTE 1: I_{O1} is rated at 2.5 A @ $T_{EC} = 75^\circ\text{C}$. Derate at 50 mA/°C for T_{EC} above 125°C.

NOTE 2: I_{O2} is rated at 1.0 A @ $T_A = 55^\circ\text{C}$ for PC boards where thermal resistance from mounting point to ambient is sufficiently controlled where $T_{J(max)}$ does not exceed 175°C. Derate at 8.33 mA/°C for T_A above 55°C.

NOTE 3: $T_A = 25^\circ\text{C}$ @ $I_O = 1.0$ A and V_{RWM} for ten 8.3 ms surges at 1 minute intervals

NOTE 4: $I_F = 0.5$ A, $I_{RM} = 0.5$ A, $I_{R(REC)} = .05$ A

SYMBOLS & DEFINITIONS

Symbol	Definition
V_{BR}	Minimum Breakdown Voltage: The minimum voltage the device will exhibit at a specified current
V_{RWM}	Working Peak Reverse Voltage: The maximum peak voltage that can be applied over the operating temperature range
I_O	Average Rectified Output Current: Output Current Averaged over a full cycle with a 50 Hz or 60 Hz sine-wave input and a 180 degree conduction angle
V_F	Maximum Forward Voltage: The maximum forward voltage the device will exhibit at a specified current
I_R	Maximum Leakage Current: The maximum leakage current that will flow at the specified voltage and temperature
C	Capacitance: The capacitance in pF at a frequency of 1 MHz and specified voltage
t_{rr}	Reverse Recovery Time: The time interval between the instant the current passes through zero when changing from the forward direction to the reverse direction and a specified recovery decay point after a peak reverse current occurs.

PACKAGE DIMENSIONS AND PAD LAYOUT

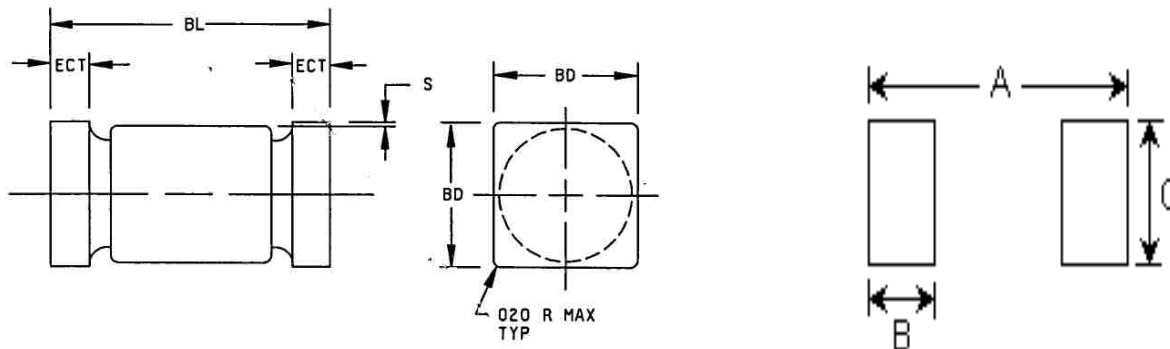

NOTE: This Package Outline has also previously been identified as "D-5A"

	INCHES		mm	
	MIN	MAX	MIN	MAX
BD	.097	.103	2.46	2.62
BL	.185	.200	4.70	5.08
ECT	.019	.028	0.48	0.71
S	.003	---	0.08	---

PAD LAYOUT

	INCHES	mm
A	0.246	6.25
B	0.067	1.70
C	0.105	2.67

Note: If mounting requires adhesive separate from the solder, an additional 0.060 inch diameter contact may be placed in the center between the pads as an optional spot for cement.