High-Power Laser Diodes

Leistungslaserdioden

High-Power Laser Diodes	Leistungslaserdioden	177
Summary of Types	Typenübersicht	179
Safety advice	Informationen zur Augensicherheit	181
Type designation	Bezeichnungsschema	181
Blue Laser Diode	Blau emittierende Laserdiode	183
Pulsed laser diodes	Impuls-Laserdioden	183
CW laser diodes (single emitter)	Laserdioden für Dauerbetrieb (Einzelemitter)	183
Laser diode array SIRILAS	Laserdioden Array SIRILAS	184
Laser bars, water-cooled (Micro-channel cooler, MCC)	Laser bars, water-cooled (Micro-channel cooler, MCC)	185
Laser stacks, water-cooled (Micro-channel cooler, MCC)	Laser stacks, water-cooled (Micro-channel cooler, MCC)	185
Unmounted laser bars	Unmontierte Laserbarren	186
Pulsed laser dies	Impuls-Laserdioden Chips	186
Outline Drawings	Maßzeichnungen	187

Summary of Types | Typenübersicht

Blue Laser Diode | Blau emittierende Laserdiode



PL T4 NSB-x
Page / Seite: 182

Pulsed laser diodes | Impuls-Laserdioden



SPL PLxx
Page / Seite: 182



SPL LLxx
Page / Seite: 182



SPL AHxx
Page / Seite: 182

CW laser diodes (single emitter) | Laserdioden für Dauerbetrieb (Einzelemitter)

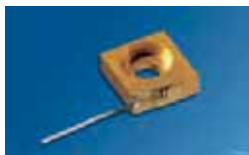

Page / Seite: 182



SPL 2Fxx
Page / Seite: 183

Laser diode array SIRILAS | Laserdioden Array SIRILAS



SPL LGxx
Page / Seite: 183

Laser bars, water-cooled (Micro-channel cooler, MCC)



SPL E01Nxx
Page / Seite: 184



SPL E01Yxx
Page / Seite: 184

Summary of Types | Typenübersicht

Laser stacks, water-cooled (Micro-channel cooler, MCC)



SPL E03xx
Page / Seite: 184



SPL E10xx
Page / Seite: 184



SPL E20xx
Page / Seite: 184

Unmounted laser bars | Unmontierte Laserbarren



SPL BGxx
Page / Seite: 185



SPL BXxx
Page / Seite: 185



SPL BSxx
Page / Seite: 185

Pulsed laser dies | Impuls-Laserdioden Chips

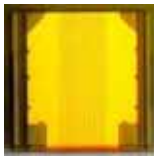

SPL DLxx
Page / Seite: 185

High-Power Laser Diodes | Leistungslaserdioden

Safety advice

Depending on the mode of operation, these devices emit highly concentrated non visible infrared light which can be hazardous to the human eye. Products which incorporate these devices have to follow the safety precautions given in IEC 60825-1 "Safety of laser products".

Informationen zur Augensicherheit

Je nach Betriebsart emittieren diese Bauteile hochkonzentrierte, nicht sichtbare Infrarot-Strahlung, die gefährlich für das menschliche Auge sein kann. Produkte, die diese Bauteile enthalten, müssen gemäß den Sicherheitsrichtlinien der IEC-Norm 60825-1 behandelt werden.

Type designation

Bezeichnungsschema

SPL	Type	Package	Subtype	Chip Type/Opt. Output	Wavelength	nm (Center)
	P	Plastic package	L	Pulsed laser	81	808
	L	Lead frame based package	H	200 µm Emitter Array	85	850
	A	Addressable Laser Array	G	50% Fill factor, 200 µm Emitter	90	905
	C	C-mount carrier	X	30% Fill factor, 150 µm Emitter	91	915
	2	sealed housing (TO- 220)	S	82.5% Fill factor	94	940
	B	Bar, unmounted	Y	Fast axis collimated (Y)	98	975
	E	Laser bars/stacks, water-cooled (MCC)	F	Fiber connector (FC)		
	D	Die, chip	N	No optics		

Note:

cw = continuous wave

qcw = quasi continuous wave

xx in the type name (e.g. SPL PLxx) refers to the wavelength

High-Power Laser Diodes | Leistungslaserdioden





Package Gehäuse	Type Bezeichnung	$\lambda_{\text{peak typ}}$ [nm]	Opt. peak power P_{opt}	V_F typ	Measurement cond.	Beam divergence (FWHM) $\Theta_{\perp} \times \Theta_{\parallel}$ [°]	Package Features	Ordering Code Bestellnummer	Package Fig. Bauteilzeichnung
			[W]	[V]					

Blue Laser Diode | Blau emittierende Laserdiode

	PL T4 NSB-1	450	0.03	5.5	$I_F = 80$ mA	21° x 7°	TO38 iCut package	on request	1
	PL T4 NSB-2		0.05						

Package Gehäuse	Type Bezeichnung	Package Outline	$\lambda_{\text{peak typ}}$ [nm]	Opt. peak power P_{opt} [W]	Beam divergence (FWHM) $\Theta_{\perp} \times \Theta_{\parallel}$ [°]	Package Features	Ordering Code Bestellnummer	Package Fig. Bauteilzeichnung
-----------------	------------------	-----------------	-------------------------------------	---	--	------------------	-----------------------------	-------------------------------

Pulsed laser diodes | Impuls-Laserdioden

	SPL PL85	Plastic housing	850	10	25° x 11°	5 mm radial plastic package, pulse width < 100 ns	Q62702P1759	2
	SPL PL90_0		905	4			Q62702P5270	
	SPL PL90			25			Q62702P1760	
	SPL PL90_3			75			Q62702P5353	
	SPL PL 90_0B	Plastic housing	905	4	25° x 11°	5 mm radial plastic package, pulse width < 100 ns	Q65110A8790	3
	SPL LL85	Plastic housing with integrated driver	850	14	30° x 15°	Integrated laser driver circuit, plastic package, pulse width < 50 ns	Q62702P3558	4
	SPL LL90		905	25			Q62702P5367	5
	SPL LL90_3			70			Q65110A1009	
	SPL AH90_3	12-channel laser array	905	75	25° x 11°	Toplooker with AR-coated window, integrated heater for wavelength stabilization	Q65110A3900	6

CW laser diodes (single emitter) | Laserdioden für Dauerbetrieb (Einzelemittler)



	SPL CG81-2S	Laser on sub-mount	808	2	38° x 7°	Open heat sink (C-type)	Q65110A1832	7
	SPL CG94-2S		940				Q65110A1833	

High-Power Laser Diodes | Leistungslaserdioden

Package Gehäuse	Type Bezeichnung	Package Outline	$\lambda_{\text{peak typ}}$ [nm]	Opt. peak power P_{opt} [W]	Fiber diameter \varnothing [μm]	Numerical aperture NA	Package Features	Ordering Code Bestellnummer	Package Fig. Bauteilzeichnung
	SPL 2F81-2S	TO-220 FC (fiber coupled)	808	1.5	200	0.22	TO-220 package, FC-receptacle for efficient fiber coupling, thermistor for temperature and wavelength control	Q65110A1722	8
	SPL 2F81-2S-105			1.2	105			Q65110A8451	
	SPL 2F94-2S		940	1.5	200			Q65110A1828	

Package Gehäuse	Type Bezeichnung	Package Outline	$\lambda_{\text{peak typ}}$ [nm]	Opt. peak power P_{opt} [W]	Beam divergence full angle ($1/e^2$) $\Theta_{\perp} \times \Theta_{\parallel}$ [°]	Package Features	Ordering Code Bestellnummer	Package Fig. Bauteilzeichnung
-----------------	------------------	-----------------	-------------------------------------	---	--	------------------	-----------------------------	-------------------------------



Laser diode array SIRILAS | Laserdioden Array SIRILAS

	SPL LG81	water cooled leadframe (type TO263)	808	30	1.4° x 6°	Packaged laser array with integrated lens for fast axis collimation, integrated cooler for efficient water cooling	Q65110A2008	9
	SPL LG81-P	conductively cooled leadframe (type TO263)	807	15	0.8° x 6°	Packaged laser array with integrated lens for fast axis collimation, conductively cooled	Q65110A5307	10
	SPL LG91-P		915		1.4° x 9°		Q65110A5574	
	SPL LG94-P		940		1.4° x 6°		Q65110A5575	
	SPL LG98-P		975				Q65110A5576	

High-Power Laser Diodes | Leistungslaserdioden



Package Gehäuse	Type Bezeichnung	Package Outline	$\lambda_{\text{peak typ}}$ [nm]	$P_{\text{opt typ}}$ [W]	Beam divergence full angle (1/e ²) $\Theta_{\perp} \times \Theta_{\parallel}$ [°]	Package Features	Ordering Code Bestellnummer	Package Fig. Bauteilzeichnung
-----------------	------------------	-----------------	-------------------------------------	-----------------------------	---	------------------	-----------------------------	-------------------------------

Laser bars, water-cooled (Micro-channel cooler, MCC)

	SPL E01N81G2	Micro channel cooler	808	60	65° x 8°	1bar	Q65110A4147	14
	SPL E01N94G2		940				Q65110A6234	
	SPL E01N98G2		975				Q65110A4151	
	SPL E01Y81G2	Micro channel cooler	808	60	1° x 8°	1 bar with lens for fast axis collimation	Q65110A4148	14

Package Gehäuse	Type Bezeichnung	Package Outline	$\lambda_{\text{peak typ}}$ [nm]	$P_{\text{opt typ}}$ [W]	Beam divergence full angle (1/e ²) $\Theta_{\perp} \times \Theta_{\parallel}$ [°]	Package Features	Ordering Code Bestellnummer	Package Fig. Bauteilzeichnung
-----------------	------------------	-----------------	-------------------------------------	-----------------------------	---	------------------	-----------------------------	-------------------------------



Laser stacks, water-cooled (Micro-channel cooler, MCC)

	SPL E03N81S9	Micro-channel cooler	808	450	65° x 8°	bar-to-bar distance 1.6mm 3 bars, for qcw applications	Q65110A6233	11
	SPL E03N81G2			180		bar-to-bar distance 1.6mm 3 bars	Q65110A4152	
	SPL E03N91G2		915			Q65110A4149		
	SPL E10N81G2	Micro-channel cooler	808	600	65° x 8°	bar-to-bar distance 1.6mm 10bars	Q65110A4153	12
	SPL E10N94G2		940				Q65110A4150	
	SPL E20N81G2	Micro-channel cooler	808	1200	65° x 8°	bar-to-bar distance 1.6mm 20 bars	Q65110A6232	13

High-Power Laser Diodes | Leistungslaserdioden

Package Gehäuse	Type Bezeichnung	Package Outline	$\lambda_{\text{peak typ}}$ [nm]	$P_{\text{opt typ}}$ [W]	Beam divergence full angle ($1/e^2$) $\Theta_{\perp} \times \Theta_{\parallel}$ [°]	Package Features	Chip size [mm x mm]	Ordering Code Bestellnummer	Package Fig. Bauteilzeichnung
-----------------	------------------	-----------------	-------------------------------------	-----------------------------	--	------------------	------------------------	-----------------------------	-------------------------------

Unmounted laser bars | Unmontierte Laserbarren

	SPL BG81-9S	unmounted laser bar	808	50	65° x 9°	50% filling factor, 25 emitters, emitter width 200 µm, emitter pitch 400 µm	10 x 0.9	Q62702P5503				
	SPL BK91-12S (911+/-3nm)		915	60			10 x 1.2	Q65110A8801				
	SPL BK94-12S (934+/-3nm)		940					Q65110A8820				
	SPL BK98-12S (972+/-3nm)		980					Q65110A8878				
	SPL BK81-20H		unmounted laser bar	808			100	65° x 9°	50% filling factor, 25 emitters, emitter width 200 µm, emitter pitch 400 µm	10 x 2	Q65110A8725	
	SPL BK91-20HT			915			Q65110A8594					
	SPL BK94-20HT			940			120				Q65110A8595	
	SPL BK98-20HT			980			Q65110A8596					
	SPL BK81-12S (802+/-3nm)		808	60			10 x 1.2	Q65110A8104				
	SPL BX81-2S	unmounted laser bar	808	40	65° x 9°	30% filling factor, 19 emitters, emitter width 150 µm, emitter pitch 500 µm	9.5 x 1.2	Q62702P5510				
	SPL BX94-2S		940					Q62702P5512				
	SPL BX98-2S		980					Q65110A0740				
	SPL BS81-6	unmounted laser bar	808	100	70° x 12°	82.5% filling factor, 75 emitters, emitter width 110 µm, emitter pitch 130 µm for qcw applications	10 x 0.6	Q62702P1719				
	SPL BS81-9S			150	65° x 9°		10 x 0.9	Q65110A2676				
	SPL BS94-2S		940	200	10 x 1.2		Q65110A6958					

Package Gehäuse	Type Bezeichnung	Package Outline	$\lambda_{\text{peak typ}}$ [nm]	Opt. peak power P_{opt} [W]	Beam divergence (FWHM) $\Theta_{\perp} \times \Theta_{\parallel}$ [°]	Package Features	Chip size [mm x mm]	Ordering Code Bestellnummer	Package Fig. Bauteilzeichnung
-----------------	------------------	-----------------	-------------------------------------	---	--	------------------	------------------------	-----------------------------	-------------------------------

Pulsed laser dies | Impuls-Laserdioden Chips

	SPL DL90_3	unmounted laser chip	905	75	25° x 11°	emitter width 200 µm	0.6 x 0.6	Q65110A2591	
---	------------	----------------------	-----	----	-----------	----------------------	-----------	-------------	--

Outline drawings - Dimensions in mm (inch) | Outline drawings - Dimensions in mm (inch)

Figure 5: SPL LL90, SPL LL90_3

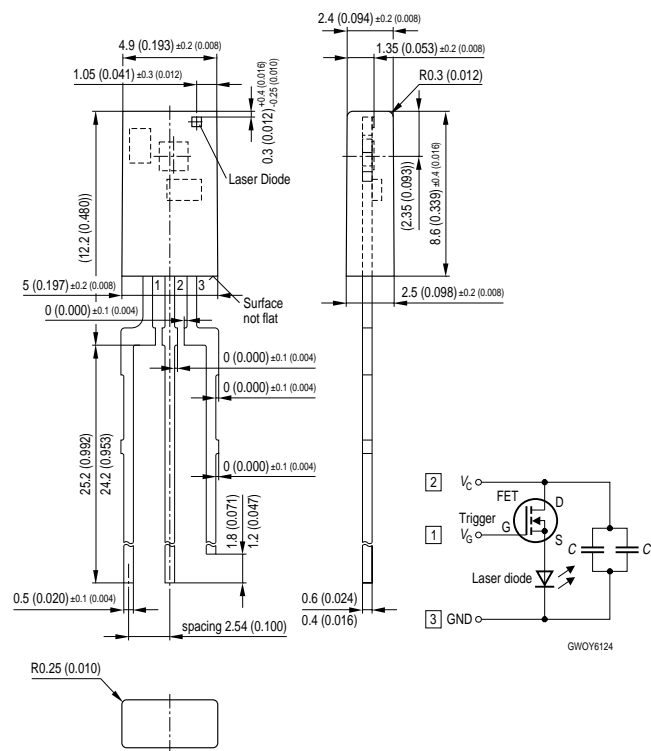

Figure 6: SPL AH90_3

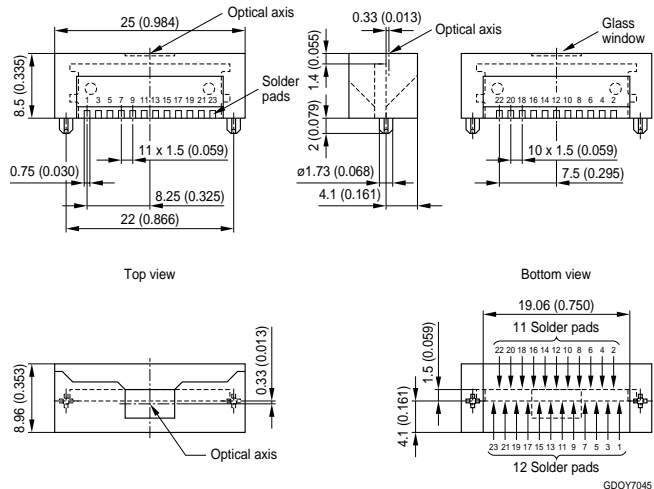

Figure 7: SPL CGxx

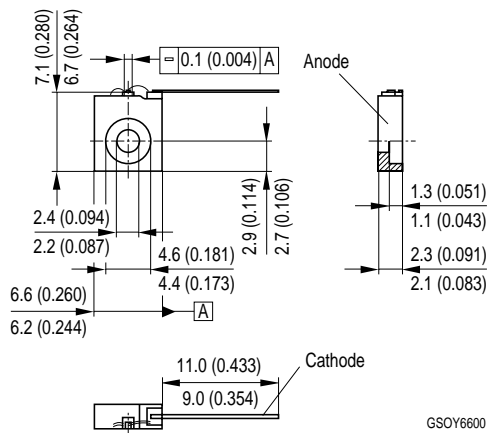
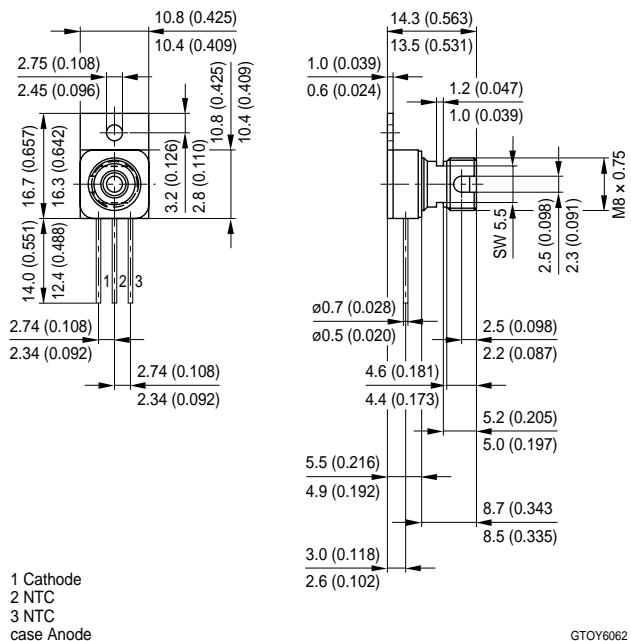

Figure 8: SPL 2Fxx



Outline drawings - Dimensions in mm (inch) | Outline drawings - Dimensions in mm (inch)

Figure 9: SPL LG81

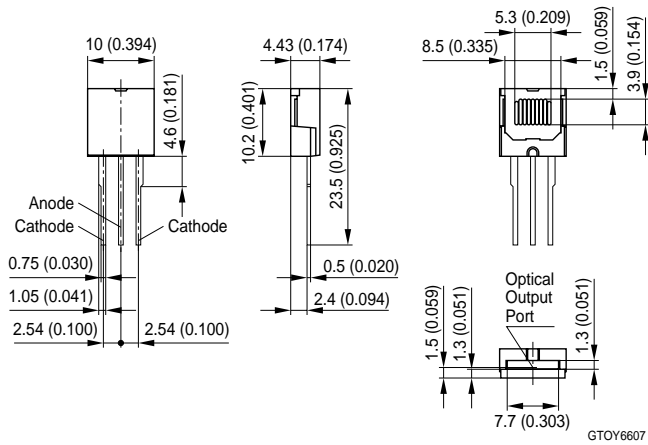

Figure 10: SPL LGxx-P

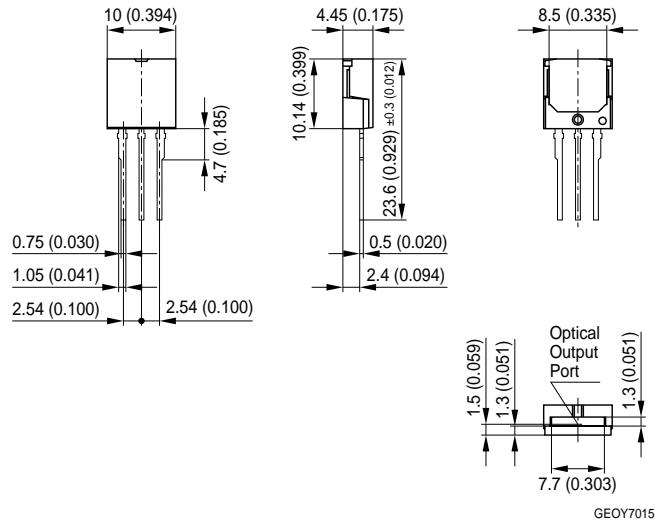

Figure 11: SPL E03xx

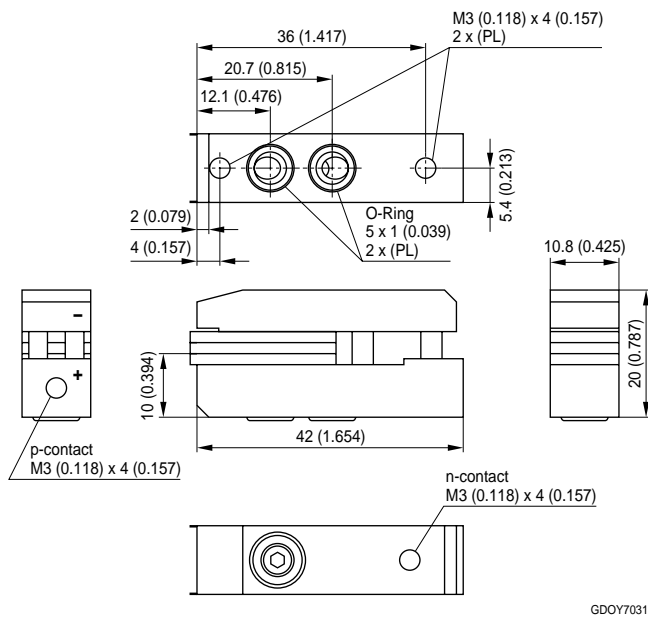
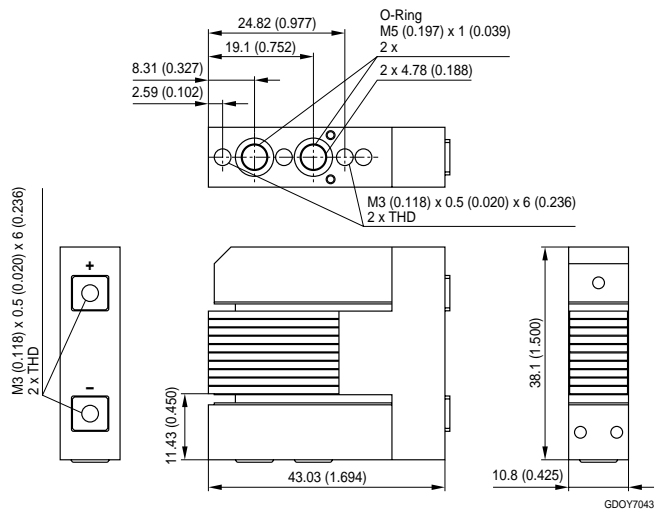

Figure 12: SPL E10xx



Outline drawings - Dimensions in mm (inch) | Outline drawings - Dimensions in mm (inch)

Figure 13: SPL E20xx

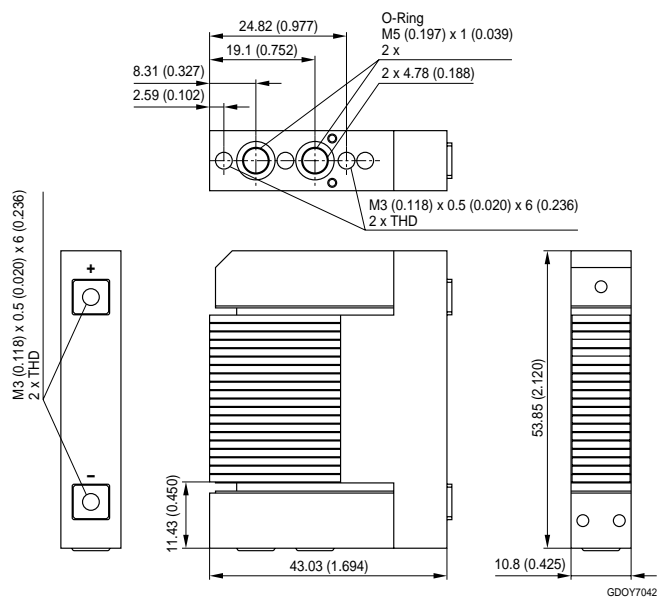

Figure 14: SPL E01Nxx

