

Nanostack Impuls-Laserdiode Nanostack Pulsed Laser Diode

Lead (Pb) Free Product - RoHS Compliant

SPL DL90_3

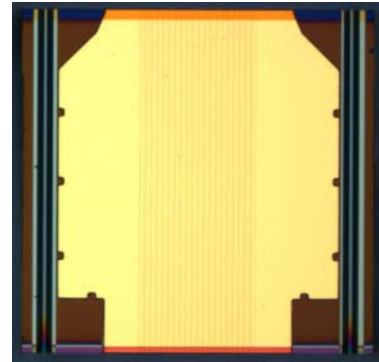

Besondere Merkmale

- Zuverlässiges InGaAs/GaAs kompressiv verspanntes Halbleiter-Material
- Hochleistungslaser mit „Large-Optical-Cavity“ (LOC) Struktur für ein schmales Fernfeld
- Nanostack Lasertechnologie beinhaltet mehrere epitaktisch integrierte Emittter
- Laterale Austrittsöffnung 200 µm × 10 µm

Anwendungen

- Entfernungsmessung
- Sicherheit, Überwachung
- Beleuchtung, Zündung
- Test- und Messsysteme

Sicherheitshinweise

Je nach Betriebsart emittieren diese Bauteile hochkonzentrierte, nicht sichtbare Infrarot-Strahlung, die gefährlich für das menschliche Auge sein kann. Produkte, die diese Bauteile enthalten, müssen gemäß den Sicherheitsrichtlinien der IEC-Norm 60825-1 behandelt werden.

Features

- Reliable strained InGaAs/GaAs material
- High power large-optical-cavity structure
- Nanostack laser technology including multiple epitaxially stacked emitters
- Laser aperture 200 µm × 10 µm

Applications

- Range finding
- Security, surveillance
- Illumination, ignition
- Test and measurement systems

Safety Advices

Depending on the mode of operation, these devices emit highly concentrated non visible infrared light which can be hazardous to the human eye. Products which incorporate these devices have to follow the safety precautions given in IEC 60825-1 “Safety of laser products”

Typ Type	Anzahl vertikal angeordneter Emittter Number of vertically stacked Emitters	Wellenlänge Wavelength	Bestellnummer Ordering Code
SPL DL90_3	3	903 nm	Q65110A2591

Optische Kennwerte ($T_A = 25\text{ °C}$)¹⁾
Optical Characteristics¹⁾

Parameter Parameter	Symbol Symbol	Werte Values			Einheit Unit
		min.	typ.	max.	
Zentrale Impulswellenlänge Standard pulse center wavelength	λ_{pulse}	896	903	910	nm
Schwellstrom Threshold current	I_{th}	-	700	850	mA
Differentielle Effizienz (1...10A) Differential efficiency (1...10A)	η_d	3.2	3.5	-	W/A
Austrittsöffnung Aperture size	$w \times h$	-	200×10	-	μm^2
Strahldivergenz schnelle Achse (Halbwertsbreite) Beam divergence fast-axis (FWHM)	θ_{\perp}	-	25	30	Grad deg.
Strahldivergenz langsame Achse (Halbwertsbreite) Beam divergence slow-axis (FWHM)	θ_{\parallel}	-	11	14	Grad deg.
Differentieller Serienwiderstand Differential series resistance	R_S	-	380	460	m Ω
Charakteristische Temperatur ($25\text{°} \dots 60\text{°C}$) ²⁾ Characteristic temperature ($25\text{°} \dots 60\text{°C}$) ²⁾	T_0	100	150	-	K

¹⁾ Alle Kenn- und Grenzwerte beziehen sich auf Impulsmessungen (1 μs Pulsbreite bei 1 kHz Wiederholfrequenz) an unmontierten Laserchips.
All characteristics and limitations refer to pulsed measurements (1 μs pulse width at 1 kHz repetition rate) on unmounted laser dice.

²⁾ Modell zur Bestimmung des thermischen Verhaltens bzgl. des Schwellstroms:

Model for the thermal behavior of threshold current:

$$I_{\text{th}}(T_2) = I_{\text{th}}(T_1) \times \exp(T_2 - T_1)/T_0$$

Exemplarische Werte zum Laserbetrieb im Plastikgehäuse finden Sie im Datenblatt zu SPL PL90_3.

For exemplary characteristics of laser operation in plastic package see datasheet of SPL PL90_3.

**Maßzeichnung
Chip Outlines**

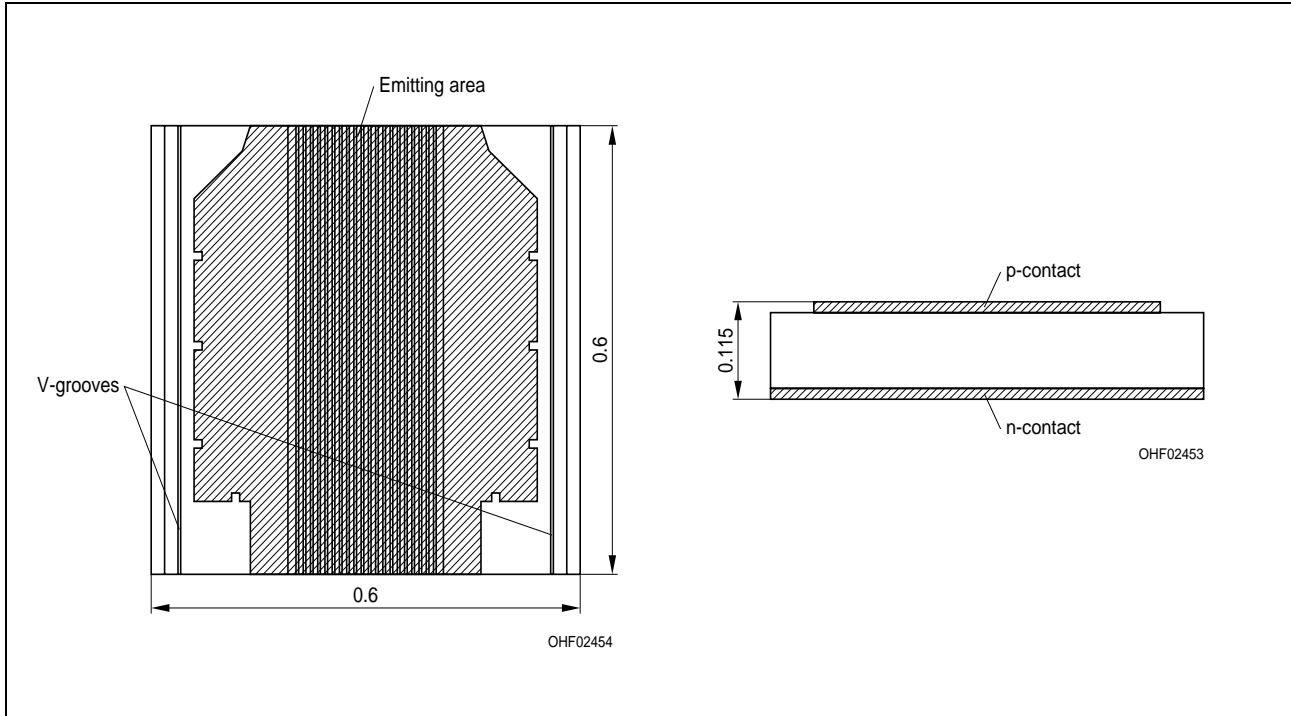

Maße werden wie folgt angegeben: mm (inch)
Dimensions are specified as follows: mm (inch).

Wire Bonding Scheme

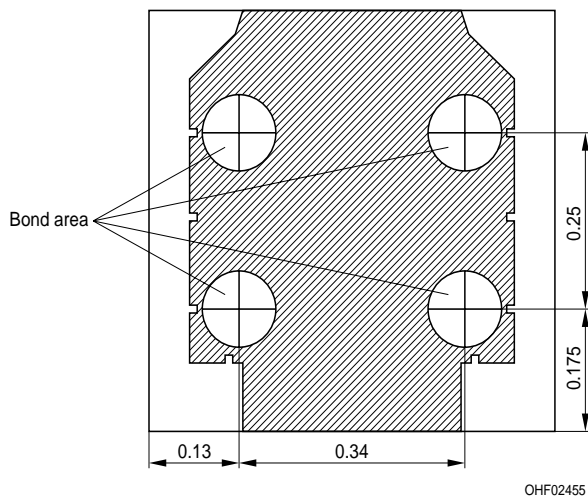

Schematic of Chip and Equivalent Circuit

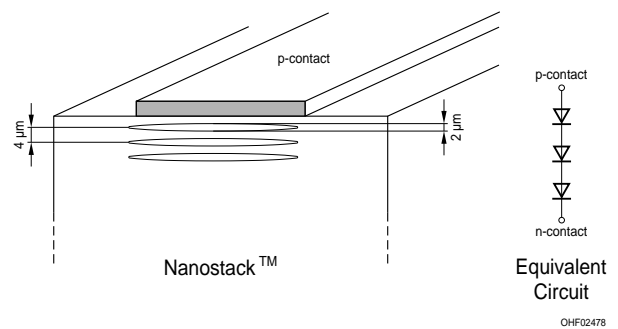

Published by
OSRAM Opto Semiconductors GmbH
Leibnizstrasse 4, D-93055 Regensburg
www.osram-os.com

© All Rights Reserved.

The information describes the type of component and shall not be considered as assured characteristics. Terms of delivery and rights to change design reserved. Due to technical requirements components may contain dangerous substances. For information on the types in question please contact our Sales Organization.

Packing

Please use the recycling operators known to you. We can also help you – get in touch with your nearest sales office. By agreement we will take packing material back, if it is sorted. You must bear the costs of transport. For packing material that is returned to us unsorted or which we are not obliged to accept, we shall have to invoice you for any costs incurred.

Components used in life-support devices or systems must be expressly authorized for such purpose! Critical components ¹, may only be used in life-support devices or systems ² with the express written approval of OSRAM OS.

¹ A critical component is a component used in a life-support device or system whose failure can reasonably be expected to cause the failure of that life-support device or system, or to affect its safety or effectiveness of that device or system.

² Life support devices or systems are intended (a) to be implanted in the human body, or (b) to support and/or maintain and sustain human life. If they fail, it is reasonable to assume that the health of the user may be endangered.

EU RoHS and China RoHS compliant product



此产品符合欧盟 RoHS 指令的要求；

按照中国的相关法规和标准，不含有毒有害物质或元素。