

Radiation Hardened 8kx8 CMOS PROM

The Intersil HS-6664RH is a radiation hardened 64k CMOS PROM, organized in an 8k word by 8-bit format. The chip is manufactured using a radiation hardened CMOS process, and utilizes synchronous circuit design techniques to achieve high speed performance with very low power dissipation.

On-chip address latches are provided, allowing easy interfacing with microprocessors that use a multiplexed address/data bus structure. The output enable control (\overline{G}) simplifies system interfacing by allowing output data bus control in addition to the chip enable control (\overline{E}). All bits are manufactured storing a logical "0" and can be selectively programmed for a logical "1" at any bit location.

Applications for the HS-6664RH CMOS PROM include low power microprocessor based instrumentation and communications systems, remote data acquisition and processing systems, and processor control storage.

Specifications for Rad Hard QML devices are controlled by the Defense Supply Center in Columbus (DSCC). The SMD numbers listed here must be used when ordering.

Detailed Electrical Specifications for these devices are contained in SMD 5962-95626. A "hot-link" is provided on our homepage for downloading.

www.intersil.com/spacedefense/space.htm

Ordering Information

ORDERING NUMBER	INTERNAL MKT. NUMBER	TEMP. RANGE (°C)
5962F9562601QXC	HS1-6664RH-8	-55 to 125
5962F9562601QYC	HS9-6664RH-8	-55 to 125
5962F9562601VXC	HS1-6664RH-Q	-55 to 125
5962F9562601VYC	HS9-6664RH-Q	-55 to 125
HS1-6664RH/PROTO	HS1-6664RH/PROTO	-55 to 125
HS9-6664RH/PROTO	HS9-6664RH/PROTO	-55 to 125

Features

- Electrically Screened to SMD # 5962-95626
- QML Qualified per MIL-PRF-38535 Requirements
- 1.2 Micron Radiation Hardened Bulk CMOS
- Total Dose 300 krad(Si) (Max)
- Transient Output Upset $>5 \times 10^8$ rad(Si)/s
- LET >100 MEV-cm²/mg
- Fast Access Time. 35ns (Typ)
- Single 5V Power Supply
- Single Pulse 10V Field Programmable
- Synchronous Operation
- On-Chip Address Latches
- Three-State Outputs
- NiCr Fuses
- Low Standby Current $<500\mu\text{A}$ (Pre-Rad)
- Low Operating Current. $<15\text{mA/MHz}$
- Military Temperature Range. -55°C to 125°C

Pinouts

28 LEAD CERAMIC (SBDIP)
CASE OUTLINE D28.6 MIL-STD-1835, CDIP2-T28
TOP VIEW

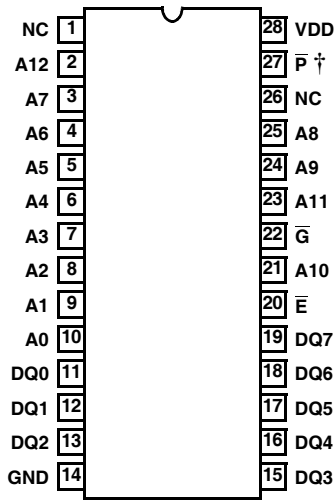

28 LEAD FLATPACK
CASE OUTLINE K28.A MIL-STD-1835, CDFP3-F28
TOP VIEW

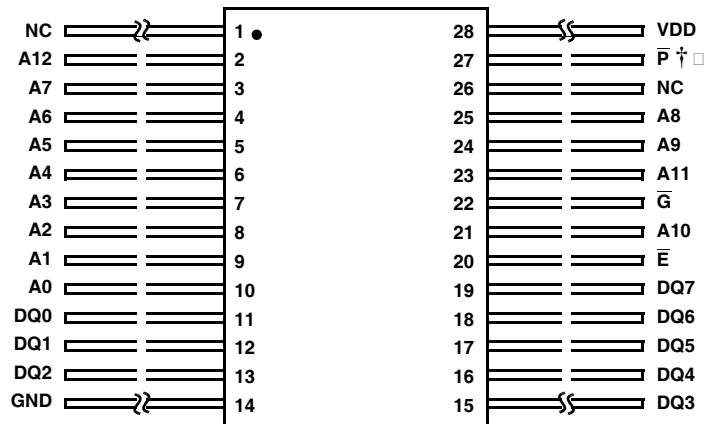

† P must be hardwired at all times to VDD, except during programming.

Functional Diagram

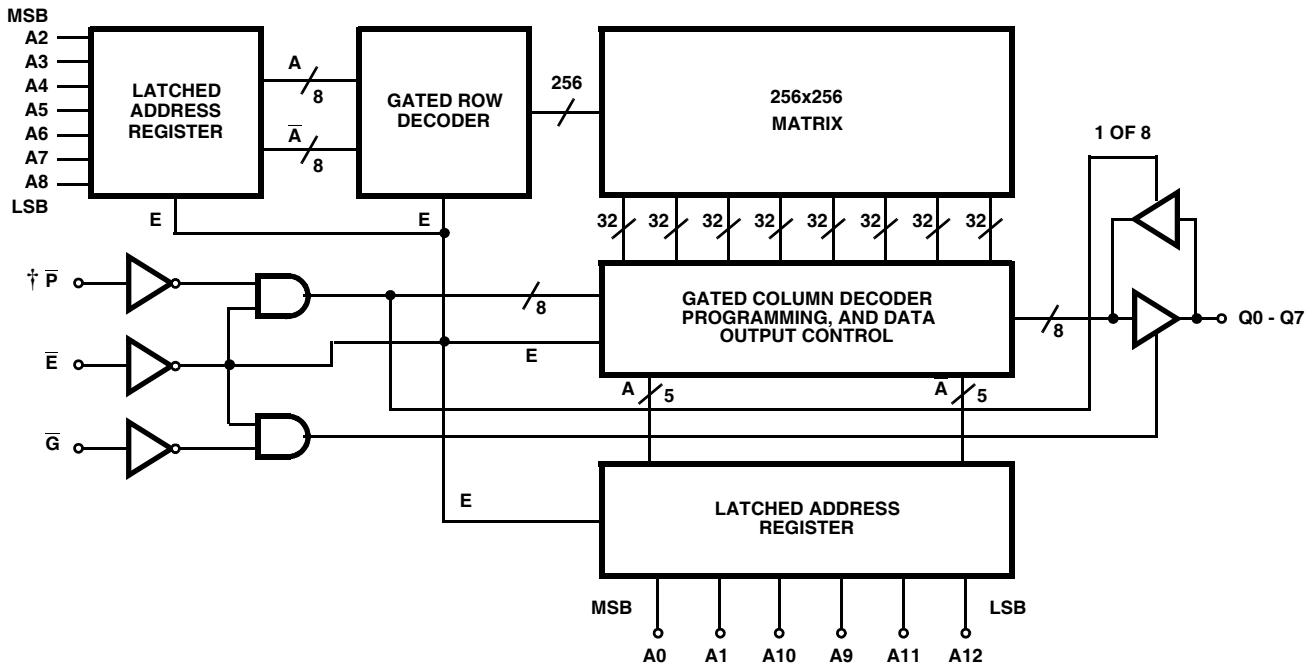

NOTE: † P must be hardwired at all times to VDD, except during programming.

TRUTH TABLE

E	G	MODE
0	0	Enabled
0	1	Output Disabled
1	X	Disabled

Burn-In Circuits

HS1-6664RH 28 LEAD (8kx8 PROM DIP)
 HS9-6664RH 28 LEAD (8kx8 PROM FLATPACK)

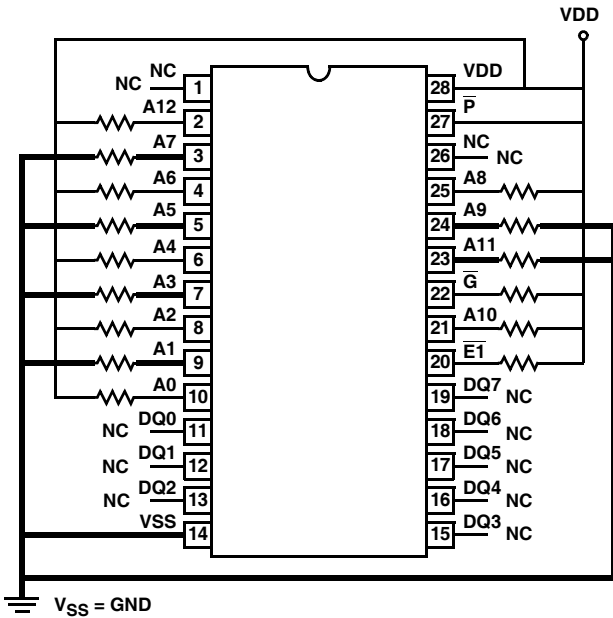

STATIC CONFIGURATION

NOTES:

1. Power Supply: VDD = 5.5V (Min)
2. Resistors = 10kΩ ± 10%

HS1-6664RH 28 LEAD (8kx8 PROM DIP)
 HS9-6664RH 28 LEAD (8kx8 PROM FLATPACK)

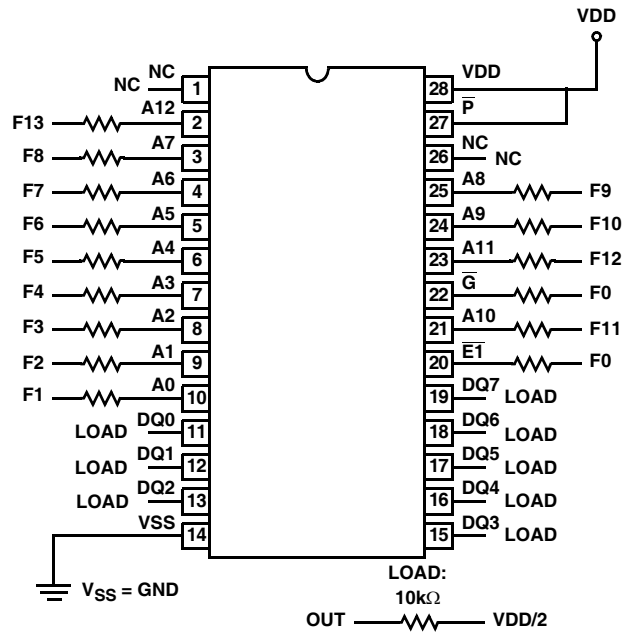

DYNAMIC CONFIGURATION

NOTES:

3. Power Supply: VDD = 5.5V (Min)
4. VIH = VDD to VDD-1.0V
5. VIL = 0.0V to 0.8V
6. Resistors = 10kΩ ± 10%
7. F0 = 100kHz ± 10%, 50% Duty Cycle
8. F1 = F0/2; F2 = F1/2; F3 = F2/2; F4 = F3/2; F5 = F4/2; . . .
 F13 = F12/2

Irradiation Circuit

HS1-6664RH 28 LEAD (8kx8 PROM DIP)

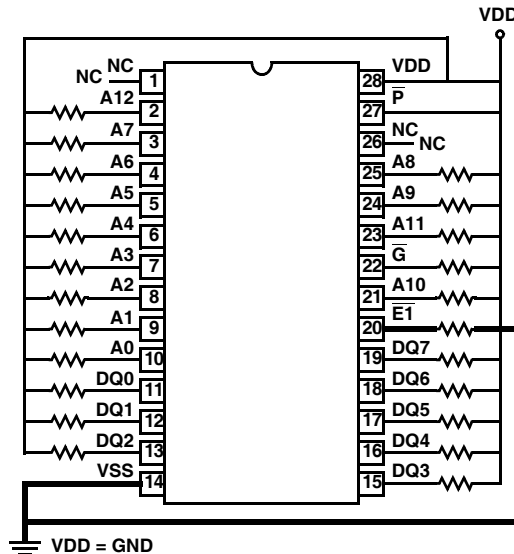

NOTES:

9. Power Supply: VDD = 5.5V ± ±0.5V
10. All Resistors = 47kΩ ± 10%

Die Characteristics

DIE DIMENSIONS:

271milsx307milsx19mils ±1mils

INTERFACE MATERIALS:

Glassivation:

Type: SiO₂
 Thickness: 8kÅ ± 1kÅ

Top Metallization:

M1: 6kÅ ± 1kÅ Si/Al/Cu
 2kÅ ± 500Å TiW
 M2: 10kÅ ± 2kÅ Si/Al/Cu

ASSEMBLY RELATED INFORMATION:

Substrate Potential:

V_{DD}

ADDITIONAL INFORMATION:

Worst Case Current Density:

2x10⁵ A/cm²

Transistor Count:

110, 874

Metallization Mask Layout

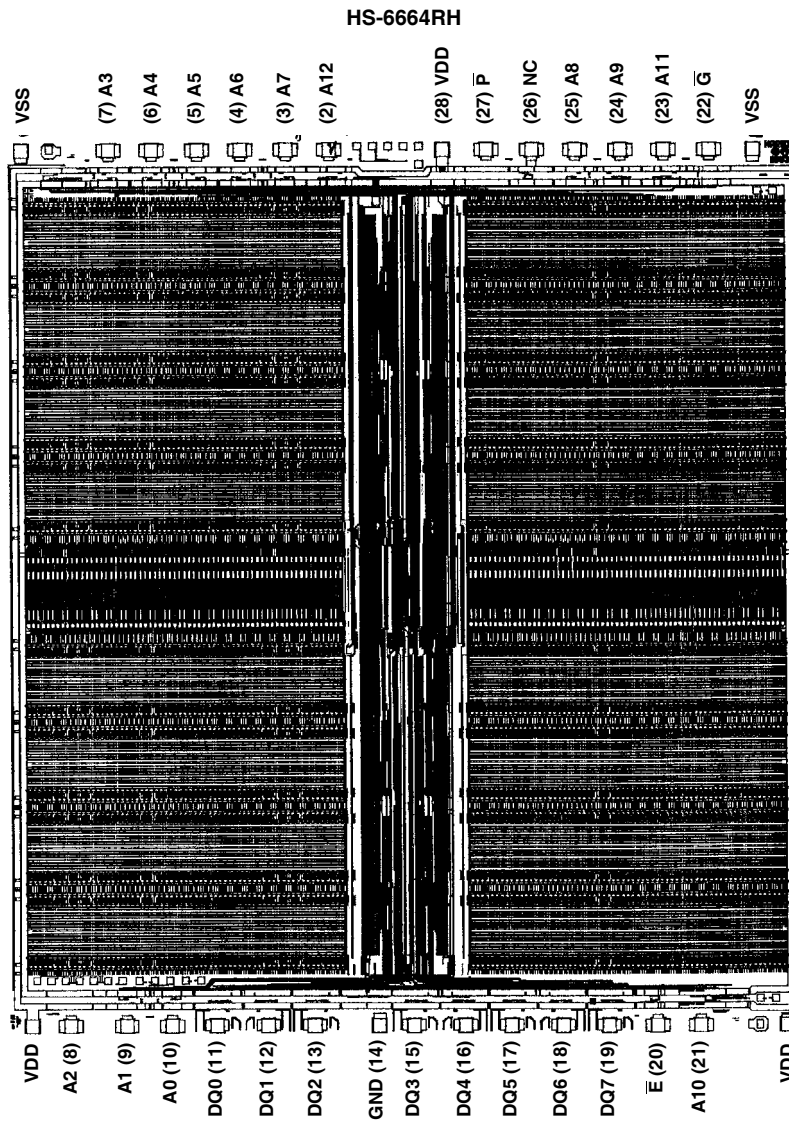

All Intersil semiconductor products are manufactured, assembled and tested under **ISO9000** quality systems certification.

Intersil semiconductor products are sold by description only. Intersil Corporation reserves the right to make changes in circuit design and/or specifications at any time without notice. Accordingly, the reader is cautioned to verify that data sheets are current before placing orders. Information furnished by Intersil is believed to be accurate and reliable. However, no responsibility is assumed by Intersil or its subsidiaries for its use; nor for any infringements of patents or other rights of third parties which may result from its use. No license is granted by implication or otherwise under any patent or patent rights of Intersil or its subsidiaries.

For information regarding Intersil Corporation and its products, see web site **www.intersil.com**

Sales Office Headquarters

NORTH AMERICA

Intersil Corporation
P. O. Box 883, Mail Stop 53-204
Melbourne, FL 32902
TEL: (321) 724-7000
FAX: (321) 724-7240

EUROPE

Intersil SA
Mercure Center
100, Rue de la Fusee
1130 Brussels, Belgium
TEL: (32) 2.724.2111
FAX: (32) 2.724.22.05

ASIA

Intersil Ltd.
8F-2, 96, Sec. 1, Chien-kuo North,
Taipei, Taiwan 104
Republic of China
TEL: 886-2-2515-8508
FAX: 886-2-2515-8369