

REVISIONS

LTR	DESCRIPTION	DATE (YR-MO-DA)	APPROVED
A	Changes in accordance with NOR 5962-R232-93	93-09-21	Michael A. Frye
B	Drawing updated to reflect current requirements. Removed programming logic from truth table B. Editorial changes throughout. - gap	00-11-02	Raymond Monnin
C	5 year review and update. Changed input capacitance from 6 pF to 10 pF. ksr	06-06-12	Raymond Monnin

THE FRONT PAGE OF THIS DRAWING HAS BEEN REPLACED

REV																				
SHEET																				
REV																				
SHEET																				

REV STATUS OF SHEETS	REV	C	C	C	C	C	C	C	C	C	C	C	C	C		
	SHEET	1	2	3	4	5	6	7	8	9	10	11				

PMIC N/A	PREPARED BY Steve Duncan	<p align="center"><b>DEFENSE SUPPLY CENTER COLUMBUS</b>  <b>COLUMBUS, OHIO 43218-3990</b>  <a href="http://www.dscc.dla.mil">http://www.dscc.dla.mil</a></p>													
<p align="center"><b>STANDARD MICROCIRCUIT DRAWING</b></p> <p>THIS DRAWING IS AVAILABLE FOR USE BY ALL DEPARTMENTS AND AGENCIES OF THE DEPARTMENT OF DEFENSE</p> <p align="center">AMSC N/A</p>	CHECKED BY Ray Monnin														
	APPROVED BY Michael A. Frye	<p align="center"><b>MICROCIRCUIT, MEMORY, DIGITAL, CMOS, 2K X 8-BIT, ONE TIME PROGRAMMABLE (OTP) PROM, MONOLITHIC SILICON</b></p>													
	DRAWING APPROVAL DATE 89-04-26														
	REVISION LEVEL C	<table border="1"> <tr> <td>SIZE A</td> <td>CAGE CODE <b>67268</b></td> <td rowspan="2"><b>5962-88734</b></td> </tr> <tr> <td colspan="2">SHEET 1 OF 11</td> </tr> </table>	SIZE A	CAGE CODE <b>67268</b>	<b>5962-88734</b>	SHEET 1 OF 11									
SIZE A	CAGE CODE <b>67268</b>	<b>5962-88734</b>													
SHEET 1 OF 11															

1. SCOPE

1.1 Scope. This drawing describes device requirements for MIL-STD-883 compliant, non-JAN class level B microcircuits in accordance with MIL-PRF-38535, appendix A.

1.2 Part or Identifying Number (PIN). The complete PIN is as shown in the following example:

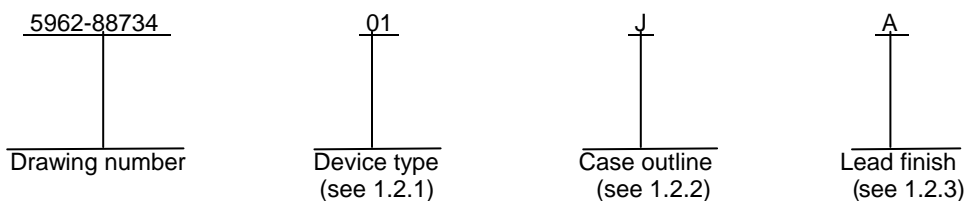

1.2.1 Device type(s). The device type(s) identify the circuit function as follows:

Device type	Generic number	Circuit function	Access time
01	7C291	2K X 8-bit PROM	55 ns
02	7C291	2K X 8-bit PROM	45 ns
03	7C291	2K X 8-bit PROM	35 ns
04	7C291	2K X 8-bit PROM	25 ns

1.2.2 Case outline(s). The case outline(s) are as designated in MIL-STD-1835 and as follows:

Outline letter	Descriptive designator	Terminals	Package style
J	GDIP1-T24 or CDIP2-T24	24	Dual-in-line package
K	GDFP2-F24 or CDFP3-F24	24	Flat package
L	GDIP3-T24 or CDIP4-T24	24	Dual-in-line package
3	CQCC1-N28	28	Square leadless chip carrier

1.2.3 Lead finish. The lead finish is as specified in MIL-PRF-38535, appendix A.

1.3 Absolute maximum ratings.

Supply voltage ( $V_{CC}$ ) .....	+4.5 V dc to +5.5 V dc
Storage temperature range .....	-65°C to +150°C
Voltage on any pin with respect to ground .....	-0.6 V dc to +7.0 V dc
$V_{PP}$ with respect to ground .....	-0.6 V dc to +13.0 V dc
Power dissipation ( $P_D$ ).....	550 mW <sup>1/</sup>
Lead temperature (soldering, 10 seconds) .....	+300°C
Thermal resistance, junction-to-case ( $\theta_{JC}$ ) .....	See MIL-STD-1835

1.4 Recommended operating conditions.

Case operating temperature range ( $T_C$ ) .....	-55°C to +125°C
--	-----------------

<sup>1/</sup> Must withstand the added  $P_D$  due to short-circuit test; e.g.,  $I_{OS}$ .

<b>STANDARD MICROCIRCUIT DRAWING</b> DEFENSE SUPPLY CENTER COLUMBUS COLUMBUS, OHIO 43218-3990	SIZE <b>A</b>		<b>5962-88734</b>
		REVISION LEVEL <b>C</b>	SHEET <b>2</b>

2. APPLICABLE DOCUMENTS

2.1 Government specification, standards, and handbooks. The following specification, standards, and handbooks form a part of this drawing to the extent specified herein. Unless otherwise specified, the issues of these documents are those cited in the solicitation or contract.

DEPARTMENT OF DEFENSE SPECIFICATION

MIL-PRF-38535 - Integrated Circuits, Manufacturing, General Specification for.

DEPARTMENT OF DEFENSE STANDARDS

MIL-STD-883 - Test Method Standard Microcircuits.  
 MIL-STD-1835 - Interface Standard Electronic Component Case Outlines.

DEPARTMENT OF DEFENSE HANDBOOKS

MIL-HDBK-103 - List of Standard Microcircuit Drawings.  
 MIL-HDBK-780 - Standard Microcircuit Drawings.

(Copies of these documents are available online at <http://assist.daps.dla.mil/quicksearch/> or <http://assist.daps.dla.mil> or from the Standardization Document Order Desk, 700 Robbins Avenue, Building 4D, Philadelphia, PA 19111-5094.)

2.2 Order of precedence. In the event of a conflict between the text of this drawing and the references cited herein, the text of this drawing takes precedence. Nothing in this document, however, supersedes applicable laws and regulations unless a specific exemption has been obtained.

3. REQUIREMENTS

3.1 Item requirements. The individual item requirements shall be in accordance with MIL-PRF-38535, appendix A for non-JAN class level B devices and as specified herein. Product built to this drawing that is produced by a Qualified Manufacturer Listing (QML) certified and qualified manufacturer or a manufacturer who has been granted transitional certification to MIL-PRF-38535 may be processed as QML product in accordance with the manufacturers approved program plan and qualifying activity approval in accordance with MIL-PRF-38535. This QML flow as documented in the Quality Management (QM) plan may make modifications to the requirements herein. These modifications shall not affect form, fit, or function of the device. These modifications shall not affect the PIN as described herein. A "Q" or "QML" certification mark in accordance with MIL-PRF-38535 is required to identify when the QML flow option is used.

3.2 Design, construction, and physical dimensions. The design, construction, and physical dimensions shall be as specified in MIL-PRF-38535, appendix A and herein.

3.2.1 Terminal connections. The terminal connections shall be as specified on figure 1.

3.2.2 Truth tables. The truth tables shall be as specified on figure 2.

3.2.2.1 Unprogrammed or erased devices. The truth table for unprogrammed devices for contracts involving no altered item drawing shall be as specified on figure 2 as applicable. When required in groups A, B, or C inspection (see 4.3), the devices shall be programmed by the manufacturer prior to test in a checkerboard pattern or equivalent (a minimum of 50 percent of the total number of bits programmed) or to any altered item drawing pattern which includes at least 25 percent of the total number of bits programmed.

3.2.2.2 Programmed devices. The truth tables for programmed devices shall be as specified by an attached altered item drawing.

3.2.3 Case outlines. The case outlines shall be in accordance with 1.2.2 herein.

3.3 Electrical performance characteristics. Unless otherwise specified herein, the electrical performance characteristics are as specified in table I and shall apply over the full case operating temperature range.

<b>STANDARD                  MICROCIRCUIT DRAWING</b> DEFENSE SUPPLY CENTER COLUMBUS COLUMBUS, OHIO 43218-3990	SIZE <b>A</b>		<b>5962-88734</b>
		REVISION LEVEL <b>C</b>	SHEET <b>3</b>

3.4 Electrical test requirements. The electrical test requirements shall be the subgroups specified in table II. The electrical tests for each subgroup are described in table I.

3.5 Marking. Marking shall be in accordance with MIL-PRF-38535, appendix A. The part shall be marked with the PIN listed in 1.2 herein. In addition, the manufacturer's PIN may also be marked. For packages where marking of the entire SMD PIN number is not feasible due to space limitations, the manufacturer has the option of not marking the "5962-" on the device.

3.5.1 Certification/compliance mark. A compliance indicator "C" shall be marked on all non-JAN devices built in compliance to MIL-PRF-38535, appendix A. The compliance indicator "C" shall be replaced with a "Q" or "QML" certification mark in accordance with MIL-PRF-38535 to identify when the QML flow option is used.

3.6 Processing options. Since the PROM is an unprogrammed memory capable of being programmed by either the manufacturer or the user to result in a wide variety of PROM configurations, two processing options are provided for selection in the contract using an altered item drawing.

3.6.1 Unprogrammed PROM delivered to the user. All testing shall be verified through group A testing as defined in 4.3.1. It is recommended that users perform subgroups 7 and 9 after programming to verify the specific program configuration.

3.6.2 Manufacturer-programmed PROM delivered to the user. All testing requirements and quality assurance provisions herein, including the requirements of the altered item drawing shall be satisfied by the manufacturer prior to delivery.

3.7 Certificate of compliance. A certificate of compliance shall be required from a manufacturer in order to be listed as an approved source of supply in MIL-HDBK-103 (see 6.6 herein). The certificate of compliance submitted to DSCC-VA prior to listing as an approved source of supply shall affirm that the manufacturer's product meets the requirements of MIL-PRF-38535, appendix A and the requirements herein.

3.8 Certificate of conformance. A certificate of conformance as required in MIL-PRF-38535, appendix A shall be provided with each lot of microcircuits delivered to this drawing.

3.9 Notification of change. Notification of change to DSCC-VA shall be required for any change that affects this drawing.

3.10 Verification and review. DSCC, DSCC's agent, and the acquiring activity retain the option to review the manufacturer's facility and applicable required documentation. Offshore documentation shall be made available onshore at the option of the reviewer.

#### 4. VERIFICATION

4.1 Sampling and inspection. Sampling and inspection procedures shall be in accordance with MIL-PRF-38535, appendix A.

4.2 Screening. Screening shall be in accordance with method 5004 of MIL-STD-883, and shall be conducted on all devices prior to quality conformance inspection. The following additional criteria shall apply:

a. Burn-in test, method 1015 of MIL-STD-883.

(1) Test condition C, D, or E. The test circuit shall be maintained by the manufacturer under document revision level control and shall be made available to the preparing or acquiring activity upon request. The test circuit shall specify the inputs, outputs, biases, and power dissipation, as applicable, in accordance with the intent specified in method 1015 of MIL-STD-883.

(2)  $T_A = +125^{\circ}\text{C}$ , minimum.

b. Interim and final electrical test parameters shall be as specified in table II herein, except interim electrical parameter tests prior to burn-in are optional at the discretion of the manufacturer.

<b>STANDARD MICROCIRCUIT DRAWING</b> DEFENSE SUPPLY CENTER COLUMBUS COLUMBUS, OHIO 43218-3990	SIZE <b>A</b>		<b>5962-88734</b>
		REVISION LEVEL <b>C</b>	SHEET <b>4</b>

TABLE I. Electrical performance characteristics.

Test	Symbol	Conditions -55°C ≤ T <sub>C</sub> ≤ +125°C 4.5 V dc ≤ V <sub>CC</sub> ≤ 5.5 V dc unless otherwise specified	Group A subgroups	Device types	Limits		Unit
					Min	Max	
Input low voltage	V <sub>IL</sub>	V <sub>CC</sub> = 4.5 V and 5.5 V	1, 2, 3	All	-0.5 <u>1/</u>	0.8	V
Input high voltage	V <sub>IH</sub>	V <sub>CC</sub> = 4.5 V and 5.5 V	1, 2, 3	All	2.0	V <sub>CC</sub> +0.5 <u>1/</u>	V
Output low voltage <u>2/</u>	V <sub>OL</sub>	I <sub>OL</sub> = 16 mA, V <sub>CC</sub> = 4.5 V V <sub>IL</sub> = 0.8 V, V <sub>IH</sub> = 2.0 V	1, 2, 3	All		0.45	V
Output high voltage <u>2/</u>	V <sub>OH</sub>	I <sub>OH</sub> = -4 mA, V <sub>CC</sub> = 4.5 V V <sub>IL</sub> = 0.8 V, V <sub>IH</sub> = 2.0 V	1, 2, 3	All	2.4		V
Output short circuit Current <u>1/</u>	I <sub>OS</sub>	V <sub>CC</sub> = 5.5 V, V <sub>OUT</sub> = GND	1, 2, 3	All		-200	mA
Input load current <u>3/</u>	I <sub>LI</sub>	V <sub>IN</sub> = 5.5 V and GND	1, 2, 3	All		±10	μA
Output leakage	I <sub>LO</sub>	V <sub>OUT</sub> = 5.5 V and GND	1, 2, 3	All		±10	μA
Operating active current <u>4/</u>	I <sub>CC</sub>	$\overline{CS}_1 = V_{IL}$ , V <sub>CC</sub> = 5.5 V 0 <sub>0</sub> to 0 <sub>7</sub> = 0 mA CS <sub>2</sub> = CS <sub>3</sub> = V <sub>IH</sub> f = 1/t <sub>ACC</sub>	1, 2, 3	All		120	mA
Input capacitance	C <sub>IN</sub>	V <sub>IN</sub> = 0 V, f = 1 MHz, T <sub>C</sub> = +25°C, see 4.3.1c	4	All		10	pF
Output capacitance	C <sub>OUT</sub>	V <sub>OUT</sub> = 0 V, f = 1 MHz, T <sub>C</sub> = +25°C, see 4.3.1c	4	All		12	pF
Address to output delay <u>5/</u>	t <sub>ACC</sub>	$\overline{CS}_1 = V_{IL}$ CS <sub>2</sub> = CS <sub>3</sub> = V <sub>IH</sub>	9, 10, 11	01		55	ns
				02		45	
				03		35	
				04		25	

See footnotes at end of table.

<b>STANDARD MICROCIRCUIT DRAWING</b> DEFENSE SUPPLY CENTER COLUMBUS COLUMBUS, OHIO 43218-3990	SIZE <b>A</b>		<b>5962-88734</b>
		REVISION LEVEL <b>C</b>	SHEET <b>5</b>

TABLE I. Electrical performance characteristics – Continued.

Test	Symbol	Conditions -55°C ≤ T <sub>C</sub> ≤ +125°C 4.5 V dc ≤ V <sub>CC</sub> = ≤ 5.5 V dc unless otherwise specified	Group A subgroups	Device types	Limits		Unit
					Min	Max	
All chip selects to output delay <u>4/</u> , <u>5/</u>	t <sub>CS</sub>	Either $\overline{CS}_1$ , CS <sub>2</sub> , or CS <sub>3</sub> <u>6/</u>	9, 10, 11	01		30	ns
				02, 03		25	
				04		20	
All chip selects high to output float <u>1/</u> , <u>5/</u>	t <sub>DF</sub>	Either $\overline{CS}_1$ , CS <sub>2</sub> , or CS <sub>3</sub> <u>6/</u>	9, 10, 11	01, 02, 03		25	ns
				04		20	
Address to output hold <u>1/</u> , <u>5/</u>	t <sub>OH</sub>	$\overline{CS}_1 = V_{IL}$ CS <sub>2</sub> = CS <sub>3</sub> = V <sub>IH</sub>	9, 10, 11	All	0		ns

1/ May not be tested, but shall be guaranteed to the limits specified in table I.

2/ These are absolute voltages with respect to device ground pin and include all over shoots due to system and/or tester noise. Do not attempt to test these values without suitable equipment.

3/ Output shall be loaded in accordance with figure 4.

4/ The addresses, (A<sub>0</sub> – A<sub>10</sub> pins), are toggling between V<sub>IL</sub> and V<sub>IH</sub>.

5/ See figures 3 and 4.

6/ Worst case of output control signal lines  $\overline{CS}_1$ , CS<sub>2</sub>, or CS<sub>3</sub>.

<b>STANDARD MICROCIRCUIT DRAWING</b> DEFENSE SUPPLY CENTER COLUMBUS COLUMBUS, OHIO 43218-3990	SIZE <b>A</b>		<b>5962-88734</b>
		REVISION LEVEL <b>C</b>	SHEET <b>6</b>

Device types	01 through 04	
Case outlines	J, K, L	3
Terminal number	Terminal symbol	
1	A <sub>7</sub>	NC
2	A <sub>6</sub>	A <sub>7</sub>
3	A <sub>5</sub>	A <sub>6</sub>
4	A <sub>4</sub>	A <sub>5</sub>
5	A <sub>3</sub>	A <sub>4</sub>
6	A <sub>2</sub>	A <sub>3</sub>
7	A <sub>1</sub>	A <sub>2</sub>
8	A <sub>0</sub>	A <sub>1</sub>
9	O <sub>0</sub>	A <sub>0</sub>
10	O <sub>1</sub>	NC
11	O <sub>2</sub>	O <sub>0</sub>
12	GND	O <sub>1</sub>
13	O <sub>3</sub>	O <sub>2</sub>
14	O <sub>4</sub>	GND
15	O <sub>5</sub>	NC
16	O <sub>6</sub>	O <sub>3</sub>
17	O <sub>7</sub>	O <sub>4</sub>
18	CS <sub>3</sub>	O <sub>5</sub>
19	CS <sub>2</sub>	O <sub>6</sub>
20	$\overline{CS}_1 / V_{PP}$	O <sub>7</sub>
21	A <sub>10</sub>	NC
22	A <sub>9</sub>	CS <sub>3</sub>
23	A <sub>8</sub>	CS <sub>2</sub>
24	V <sub>CC</sub>	$\overline{CS}_1 / V_{PP}$
25	---	A <sub>10</sub>
26	---	A <sub>9</sub>
27	---	A <sub>8</sub>
28	---	V <sub>CC</sub>

FIGURE 1. Terminal connections.

<b>STANDARD MICROCIRCUIT DRAWING</b> DEFENSE SUPPLY CENTER COLUMBUS COLUMBUS, OHIO 43218-3990	SIZE <b>A</b>		<b>5962-88734</b>
		REVISION LEVEL <b>C</b>	SHEET <b>7</b>

Truth table A

	$\overline{CS}_1/V_{PP}$	$CS_2$	$CS_3$	I/O pins
Programs	$V_{PP}$	C	C	Data in
Read	$V_{IL}$	$V_{IH}$	$V_{IH}$	Data out
Deselect	$V_{IH}$	X	X	High - Z
Deselect	X	$V_{IL}$	X	High - Z
Deselect	X	X	$V_{IL}$	High - Z

Truth table B

Pin functions				
Mode	$CS_3$	$CS_2$	$\overline{CS}_1$	Outputs
Read	$V_{IH}$	$V_{IH}$	$V_{IL}$	Data out
Output disable <u>1/</u>	X	X	$V_{IH}$	High - Z
Output disable <u>1/</u>	X	$V_{IL}$	X	High - Z
Output disable <u>1/</u>	$V_{IL}$	X	X	High - Z

NOTES:

1. X = Don't care but not to exceed  $V_{CC}$  plus 5%.

FIGURE 2. Truth tables.

<b>STANDARD MICROCIRCUIT DRAWING</b> DEFENSE SUPPLY CENTER COLUMBUS COLUMBUS, OHIO 43218-3990	SIZE <b>A</b>		<b>5962-88734</b>
		REVISION LEVEL <b>C</b>	SHEET <b>8</b>



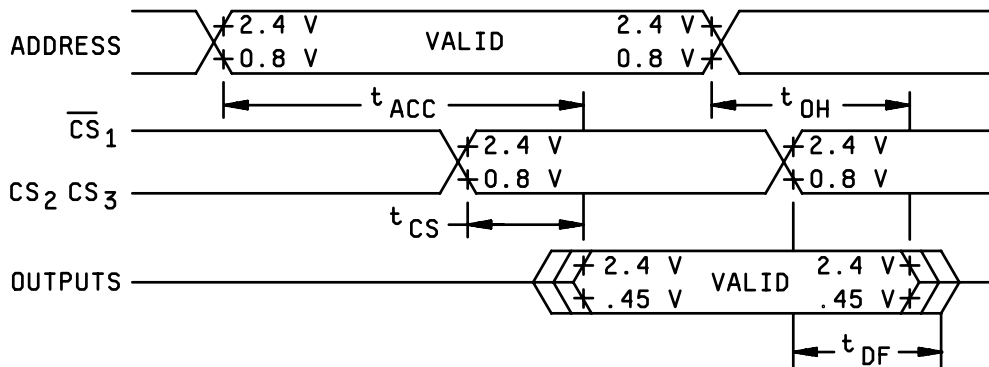

FIGURE 3. AC read timing diagram.

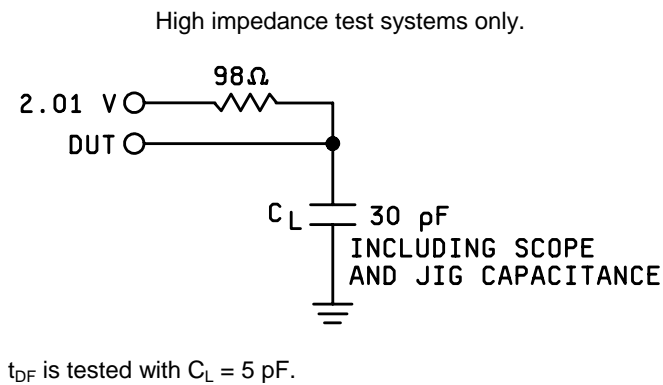

FIGURE 4. Output load.

<b>STANDARD MICROCIRCUIT DRAWING</b> DEFENSE SUPPLY CENTER COLUMBUS COLUMBUS, OHIO 43218-3990	SIZE <b>A</b>		<b>5962-88734</b>
		REVISION LEVEL <b>C</b>	SHEET <b>9</b>

TABLE II. Electrical test requirements. 1/

MIL-STD-883 test requirements	Subgroups (in accordance with MIL-STD-883, method 5005, table I)
Interim electrical parameters (method 5004)	---
Final electrical test parameters (method 5004) for unprogrammed devices	1*, 2, 3, 7*, 8
Final electrical test parameters (method 5004) for programmed devices	1*, 2, 3, 7*, 8, 9
Group A test requirements (method 5005)	1, 2, 3, 4**, 7, 8, 9, 10, 11
Groups C and D end-point electrical parameters (method 5005)	2, 3, 7, 8

\* PDA applies to subgroup 1 and 7.

\*\* See 4.3.1c.

1/ Any subgroups at the same temperature may be combined when using a multifunction tester.

4.3 Quality conformance inspection. Quality conformance inspection shall be in accordance with method 5005 of MIL-STD-883 including groups A, B, C, and D inspections. The following additional criteria shall apply.

4.3.1 Group A inspection.

- a. Tests shall be as specified in table II herein.
- b. Subgroups 5 and 6 in table I, method 5005 of MIL-STD-883 shall be omitted.
- c. Subgroup 4 ( $C_{IN}$  and  $C_{OUT}$  measurements) shall be measured only for the initial test and after process or design changes which may affect input or output capacitance. Sample size is 15 devices with no failures, and all input and output terminals tested.
- d. Unprogrammed devices shall be tested for programmability and ac performance compliance to the requirements of group A, subgroups 9, 10, and 11. Either of two techniques is acceptable:
  - (1) Testing the entire lot using additional built-in test circuitry which allows the manufacturer to verify programmability and ac performance without programming the user array. If this is done, the resulting test patterns shall be verified on all devices during subgroups 9, 10, and 11, group A testing in accordance with the sampling plan specified in MIL-STD-883, method 5005.
  - (2) If such compliance cannot be tested on an unprogrammed device, a sample shall be selected to satisfy programmability requirements prior to performing subgroups 9, 10, and 11. Twelve devices shall be submitted to programming (see 4.4). If more than two devices fail to program, the lot shall be rejected. At the manufacturer's option, the sample may be increased to 24 total devices with no more than four total device failures allowable. Ten devices from the programmability sample shall be submitted to the requirements of group A, subgroups 9, 10, and 11. If more than two devices fail, the lot shall be rejected. At the manufacturer's option, the sample may be increased to 20 total devices with no more than four total device failures allowable.
- e. Subgroups 7 and 8 shall include verification of the truth table.

<b>STANDARD MICROCIRCUIT DRAWING</b> DEFENSE SUPPLY CENTER COLUMBUS COLUMBUS, OHIO 43218-3990	SIZE <b>A</b>		<b>5962-88734</b>
		REVISION LEVEL <b>C</b>	SHEET <b>10</b>

4.3.2 Groups C and D inspections.

- a. End-point electrical parameters shall be as specified in table II herein.
- b. Steady-state life test conditions, method 1005 of MIL-STD-883.
  - (1) Test condition C, D, or E. The test circuit shall be maintained by the manufacturer under document revision level control and shall be made available to the preparing or acquiring activity upon request. The test circuit shall specify the inputs, outputs, biases, and power dissipation, as applicable, in accordance with the intent specified in method 1005 of MIL-STD-883.
  - (2)  $T_A = +125^{\circ}\text{C}$ , minimum.
  - (3) Test duration: 1,000 hours, except as permitted by method 1005 of MIL-STD-883.

4.4 Programming procedures. The programming procedures shall be as specified by the device manufacturer.

5. PACKAGING

5.1 Packaging requirements. The requirements for packaging shall be in accordance with MIL-PRF-38535, appendix A.

6. NOTES

6.1 Intended use. Microcircuits conforming to this drawing are intended for use for Government microcircuit applications (original equipment), design applications, and logistics purposes.

6.2 Replaceability. Microcircuits covered by this drawing will replace the same generic device covered by a contractor-prepared specification or drawing.

6.3 Configuration control of SMD's. All proposed changes to existing SMD's will be coordinated with the users of record for the individual documents. This coordination will be accomplished in accordance with MIL-STD-973 using DD Form 1692, Engineering Change Proposal.

6.4 Record of users. Military and industrial users shall inform Defense Supply Center Columbus (DSCC) when a system application requires configuration control and the applicable SMD. DSCC will maintain a record of users and this list will be used for coordination and distribution of changes to the drawings. Users of drawings covering microelectronics devices (FSC 5962) should contact DSCC-VA, telephone (614) 692-0544.

6.5 Comments. Comments on this drawing should be directed to DSCC-VA, Columbus, Ohio 43218-3990, or telephone (614) 692-0547.

6.6 Approved sources of supply. Approved sources of supply are listed in MIL-HDBK-103. The vendors listed in MIL-HDBK-103 have agreed to this drawing and a certificate of compliance (see 3.7 herein) has been submitted to and accepted by DSCC-VA.

<b>STANDARD MICROCIRCUIT DRAWING</b> DEFENSE SUPPLY CENTER COLUMBUS COLUMBUS, OHIO 43218-3990	SIZE <b>A</b>		<b>5962-88734</b>
		REVISION LEVEL <b>C</b>	SHEET <b>11</b>

STANDARD MICROCIRCUIT DRAWING BULLETIN

DATE: 06-06-12

Approved sources of supply for SMD 5962-88734 are listed below for immediate acquisition information only and shall be added to MIL-HDBK-103 and QML-38535 during the next revision. MIL-HDBK-103 and QML-38535 will be revised to include the addition or deletion of sources. The vendors listed below have agreed to this drawing and a certificate of compliance has been submitted to and accepted by DSCC-VA. This information bulletin is superseded by the next dated revision of MIL-HDBK-103 and QML-38535. DSCC maintains an online database of all current sources of supply at <http://www.dscclia.mil/Programs/Smcr/>.

Standard microcircuit drawing PIN <u>1</u> /	Vendor CAGE number	Vendor similar PIN <u>2</u> /
5962-8873401JA	0C7V7 0C7V7	WS57C191C-55YMB QP7C292A-55DMB
5962-8873401KA	0C7V7 0C7V7	WS57C191C-55HMB QP7C291A-55KMB
5962-8873401LA	0C7V7 0C7V7 0C7V7	WS57C291C-55KMB QP7C291A-55DMB 7C291A-55DMB
5962-88734013A	0C7V7 0C7V7	WS57C291C-55ZMB QP7C291A-55LMB
5962-88734013C	0C7V7	WS57C291C-55ZMB
5962-8873402JA	<u>3</u> / 0C7V7 0C7V7	CY7C292A-45DMB WS57C191C-45YMB QP7C292A-45DMB
5962-8873402KA	<u>3</u> / 0C7V7 0C7V7	CY7C291A-45KMB WS57C191C-45HMB QP7C291A-45KMB
5962-8873402LA	<u>3</u> / 0C7V7 0C7V7 0C7V7	CY7C291A-45DMB WS57C291C-45KMB 7C291A-45DMB QP7C291A-45DMB
5962-88734023A	65786 0C7V7 0C7V7	CY7C291A-45LMB WS57C291C-45ZMB QP7C291A-45LMB
5962-88734023C	0C7V7	WS57C291C-45ZMB
5962-88734033A	<u>3</u> / 0C7V7 0C7V7	CY7C291A-35LMB WS57C291C-35ZMB QP7C291A-35LMB
5962-88734033C	0C7V7	WS57C291C-35ZMB
5962-8873403JA	<u>3</u> / 0C7V7 0C7V7	CY7C292A-35DMB WS57C191C-35YMB QP7C292A-35DMB
5962-8873403KA	<u>3</u> / 0C7V7 0C7V7	CY7C291A-35KMB WS57C191C-35HMB QP7C291A-35KMB

See notes at end of table.

STANDARD MICROCIRCUIT DRAWING BULLETIN – Continued.

Standard microcircuit drawing PIN <u>1/</u>	Vendor CAGE number	Vendor similar PIN <u>2/</u>
5962-8873403LA	<u>3/</u> 0C7V7 0C7V7 0C7V7	CY7C291A-35DMB WS57C291C-35KMB QP7C291A-35DMB 7C291A-35DMB
5962-8873404JA	<u>3/</u> 0C7V7 0C7V7	CY7C292A-25DMB WS57C191C-25YMB QP7C292A-25DMB
5962-8873404KA	<u>3/</u> 0C7V7 0C7V7	CY7C291A-25KMB WS57C191C-25HMB QP7C291A-25KMB
5962-8873404LA	65786 0C7V7 0C7V7	CY7C291A-25DMB WS57C291C-25KMB QP7C291A-25DMB
5962-88734043A	<u>3/</u> 0C7V7 0C7V7	CY7C291A-25LMB WS57C291C-25ZMB QP7C291A-25LMB
5962-88734043C	0C7V7	WS57C291C-25ZMB

1/ The lead finish shown for each PIN representing a hermetic package is the most readily available from the manufacturer listed for that part. If the desired lead finish is not listed contact the vendor to determine its availability.

2/ **Caution.** Do not use this number for item acquisition. Items acquired to this number may not satisfy the performance requirements of this drawing.

3/ No longer available from an approved source of supply.

<u>Vendor CAGE number</u>	<u>Vendor name and address</u>	<u>Truth table</u>
65786	Cypress Semiconductor Inc 3901 North First Street San Jose, CA 94134-1506	B
0C7V7	QP Semiconductor 2945 Oakmead Village Court Santa Clara, CA 95051	B

The information contained herein is disseminated for convenience only and the Government assumes no liability whatsoever for any inaccuracies in the information bulletin.