

## HIGH SPEED 32K x 8 CMOS PROM/RPROM

### KEY FEATURES

- **Ultra-Fast Access Time**  
— 35 ns
- **Low Power Consumption**
- **Fast Programming**
- **Immune to Latch-UP**  
— Up to 200 mA
- **ESD Protection Exceeds 2000V**
- **Available in 300 Mil DIP and PLDCC**

### GENERAL DESCRIPTION

The WS57C71C is a High Performance 256K UV Erasable Electrically Re-Programmable Read Only Memory (RPROM). It is manufactured in an advanced CMOS technology and utilizes WSI's patented self-aligned split gate EPROM cell.

The industry standard PROM pin configuration of the WS57C71C provides an easy upgrade path from a 16K x 8 device.

This RPROM is capable of operating at speeds as fast as 35 ns address access time, which enables it to be used directly with today's fast microprocessors and DSP processors without introducing any wait states. All inputs and outputs are TTL compatible. The WS57C71C is a low power device even when operated at its fastest speed. The DIP version is packaged in a 300 mil wide DIP package saving board space for the user.

### BLOCK DIAGRAM

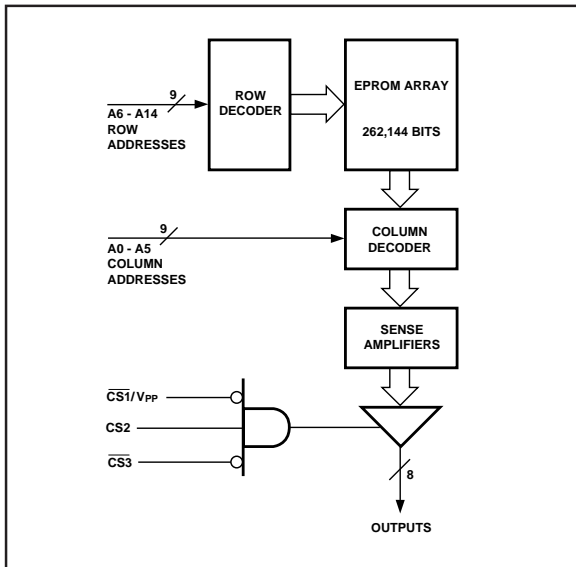

### PIN CONFIGURATION

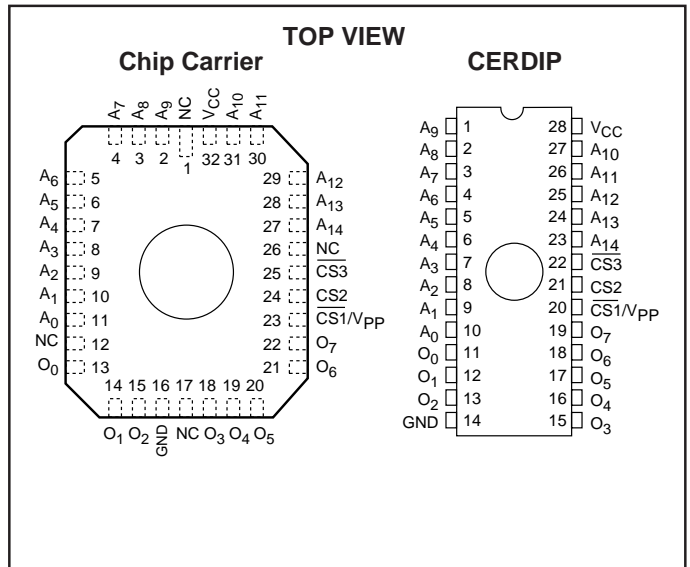

### PRODUCT SELECTION GUIDE

PARAMETER	WS57C71C-35	WS57C71C-45	WS57C71C-55	WS57C71C-70
Address Access Time (Max)	35 ns	45 ns	55 ns	70 ns
CS to Output Valid Time (Max)	15 ns	20 ns	20 ns	30 ns

**ABSOLUTE MAXIMUM RATINGS\***

Storage Temperature.....-65° to + 150°C  
 Voltage on any Pin with Respect to Ground .....-0.6V to +7V  
 V<sub>PP</sub> with Respect to Ground.....-0.6V to + 13V  
 ESD Protection.....>2000V

**\*NOTICE:**

Stresses above those listed under "Absolute Maximum Ratings" may cause permanent damage to the device. This is a stress rating only and functional operation of the device at these or any other conditions above those indicated in the operational sections of this specification is not implied. Exposure to absolute maximum rating conditions for extended periods of time may affect device reliability.

**MODE SELECTION**

<b>PINS MODE</b>	<b>CS1/ V<sub>PP</sub></b>	<b>CS2</b>	<b>CS3</b>	<b>V<sub>CC</sub></b>	<b>OUTPUTS</b>
Read	V <sub>IL</sub>	V <sub>IH</sub>	V <sub>IL</sub>	V <sub>CC</sub>	D <sub>OUT</sub>
Output Disable	V <sub>IH</sub>	X	X	V <sub>CC</sub>	High Z
Output Disable	X	V <sub>IL</sub>	X	V <sub>CC</sub>	High Z
Output Disable	X	X	V <sub>IH</sub>	V <sub>CC</sub>	High Z
Program	V <sub>PP</sub>	X	V <sub>IH</sub>	V <sub>CC</sub>	D <sub>IN</sub>
Program Verify	V <sub>IL</sub>	V <sub>IH</sub>	V <sub>IL</sub>	V <sub>CC</sub>	D <sub>OUT</sub>
Program Inhibit	V <sub>PP</sub>	V <sub>IH</sub>	V <sub>IL</sub>	V <sub>CC</sub>	D <sub>OUT</sub>

**OPERATING RANGE**

<b>RANGE</b>	<b>TEMPERATURE</b>	<b>V<sub>CC</sub></b>
Commercial	0°C to +70°C	+5V ± 10%
Industrial	-40°C to +85°C	+5V ± 10%
Military	-55°C to +125°C	+5V ± 10%

**DC READ CHARACTERISTICS** Over Operating Range. (See Above)

<b>SYMBOL</b>	<b>PARAMETER</b>	<b>TEST CONDITIONS</b>	<b>MIN</b>	<b>MAX</b>	<b>UNITS</b>
V <sub>IL</sub>	Input Low Voltage	(Note 3)	-0.1	0.8	V
V <sub>IH</sub>	Input High Voltage	(Note 3)	2.0	V <sub>CC</sub> + 0.3	V
V <sub>OL</sub>	Output Low Voltage	I <sub>OL</sub> = 16 mA		0.4	V
V <sub>OH</sub>	Output High Voltage	I <sub>OH</sub> = -4 mA	2.4		V
I <sub>CC1</sub>	V <sub>CC</sub> Active Current (CMOS)	V <sub>CC</sub> = 5.5 V, f = 0 MHz (Note 1), Output Not Loaded Add 3 mA/MHz for AC Operation	Comm'l	30	mA
			Industrial	35	mA
			Military	35	mA
I <sub>CC2</sub>	V <sub>CC</sub> Active Current (TTL)	V <sub>CC</sub> = 5.5 V, f = 0 MHz (Note 2), Output Not Loaded Add 3 mA/MHz for AC Operation	Comm'l	50	mA
			Industrial	60	mA
			Military	60	mA
I <sub>LI</sub>	Input Leakage Current	V <sub>IN</sub> = 5.5V or Gnd	-10	10	µA
I <sub>LO</sub>	Output Leakage Current	V <sub>OUT</sub> = 5.5 V or Gnd	-10	10	µA

- NOTES:**
1. CMOS inputs: GND ± 0.3V or V<sub>CC</sub> ± 0.3V.
  2. TTL inputs: V<sub>IL</sub> ≤ 0.8V, V<sub>IH</sub> ≥ 2.0V.
  3. These are absolute voltages with respect to device ground pin and include all overshoots due to system and/or tester noise. Do not attempt to test these values without suitable equipment.



**AC READ CHARACTERISTICS** Over Operating Range. (See Above)

PARAMETER	SYMBOL	57C71C-35		57C71C-45		57C71C-55		57C71C-70		UNITS
		MIN	MAX	MIN	MAX	MIN	MAX	MIN	MAX	
Address to Output Delay	$t_{ACC}$		35		45		55		70	ns
$\overline{CS}$ to Output Delay	$t_{CS}$		15		20		20		30	
Output Disable to Output Float*	$t_{DF}$		20		20		20		25	
Address to Output Hold	$t_{OH}$	0		0		0		0		

\*Sampled, Not 100% Tested.

**AC READ TIMING DIAGRAM**

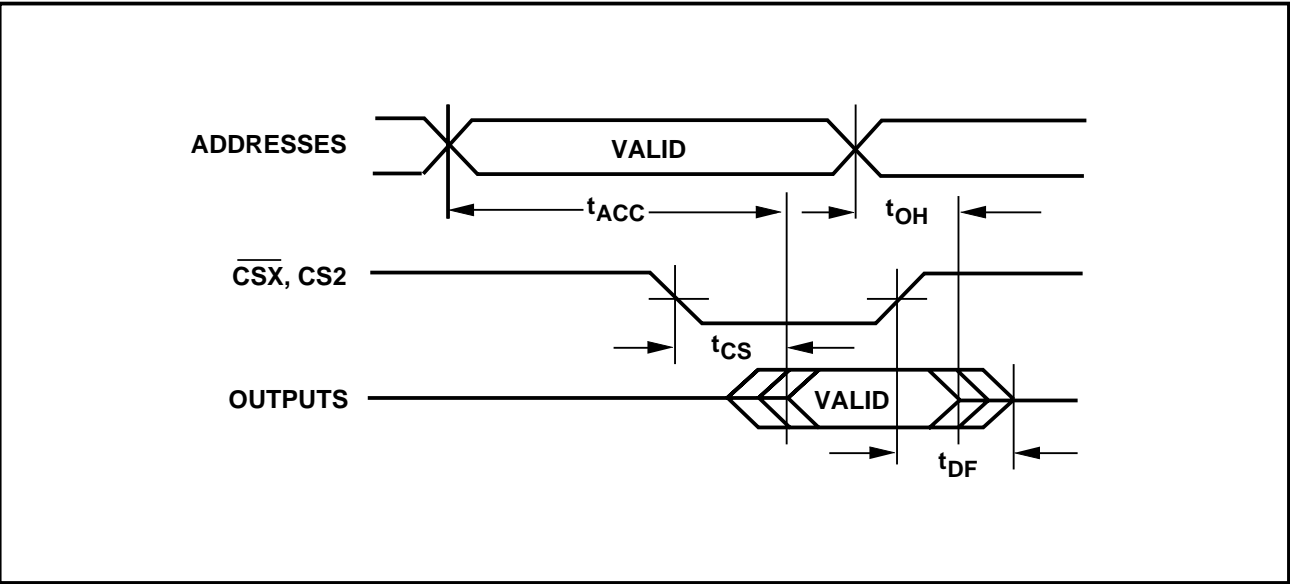

**CAPACITANCE**<sup>(4)</sup>  $T_A = 25^\circ\text{C}$ ,  $f = 1\text{ MHz}$

SYMBOL	PARAMETER	CONDITIONS	TYP <sup>(5)</sup>	MAX	UNITS
$C_{IN}$	Input Capacitance	$V_{IN} = 0\text{V}$	4	6	pF
$C_{OUT}$	Output Capacitance	$V_{OUT} = 0\text{V}$	8	12	pF
$C_{VPP}$	$V_{PP}$ Capacitance	$V_{PP} = 0\text{V}$	18	25	pF

**NOTES:** 4. This parameter is only sampled and is not 100% tested.  
 5. Typical values are for  $T_A = 25^\circ\text{C}$  and nominal supply voltages.

**TEST LOAD** (High Impedance Test Systems)

**A.C. TESTING INPUT/OUTPUT WAVEFORM**

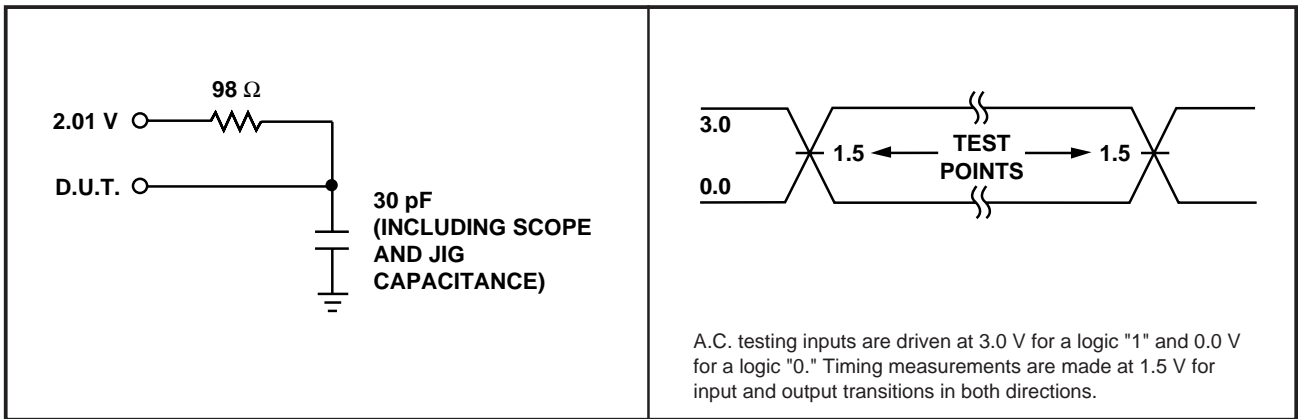

**NOTE:** 6. Provide adequate decoupling capacitance as close as possible to this device to achieve the published A.C. and D.C. parameters. A 0.1 microfarad capacitor in parallel with a 0.01 microfarad capacitor connected between  $V_{CC}$  and ground is recommended. Inadequate decoupling may result in access time degradation or other transient performance failures.



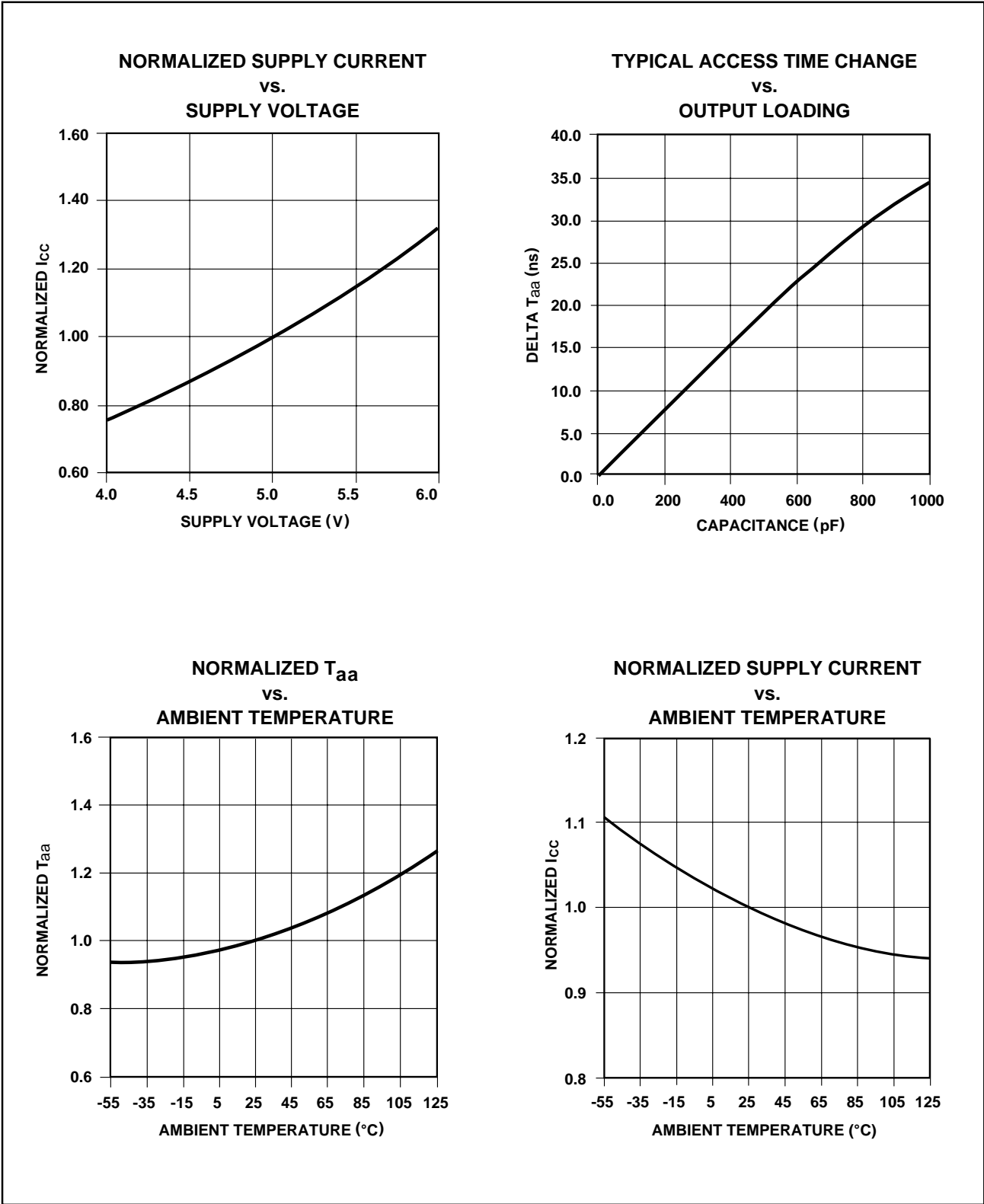

**PROGRAMMING INFORMATION**

**DC CHARACTERISTICS** ( $T_A = 25 \pm 5^\circ\text{C}$ ,  $V_{CC} = 6.25 \text{ V} \pm 0.25 \text{ V}$ ,  $V_{PP} = 12.75 \pm 0.25 \text{ V}$ )

SYMBOLS	PARAMETER	MIN	MAX	UNITS
$I_{LI}$	Input Leakage Current ( $V_{IN} = V_{CC}$ or Gnd)	-10	10	$\mu\text{A}$
$I_{PP}$	$V_{PP}$ Supply Current During Programming Pulse		60	mA
$I_{CC}$	$V_{CC}$ Supply Current		25	mA
$V_{OL}$	Output Low Voltage During Verify ( $I_{OL} = 16 \text{ mA}$ )		0.45	V
$V_{OH}$	Output High Voltage During Verify ( $I_{OH} = -4 \text{ mA}$ )	2.4		V

**NOTE:** 7.  $V_{PP}$  must not be greater than 13 volts including overshoot.

**AC CHARACTERISTICS** ( $T_A = 25 \pm 5^\circ\text{C}$ ,  $V_{CC} = 6.25 \text{ V} \pm 0.25 \text{ V}$ ,  $V_{PP} = 12.75 \pm 0.25 \text{ V}$ )

SYMBOLS	PARAMETER	MIN	TYP	MAX	UNITS
$t_{AS}$	Address Setup Time	2			$\mu\text{s}$
$t_{DF}$	Chip Disable Setup Time			30	ns
$t_{DS}$	Data Setup Time	2			$\mu\text{s}$
$t_{PW}$	Program Pulse Width	100		200	$\mu\text{s}$
$t_{DH}$	Data Hold Time	2			$\mu\text{s}$
$t_{CS}$	Chip Select Delay			30	ns
$t_{RF}$	$V_{PP}$ Rise and Fall Time	1			$\mu\text{s}$

**PROGRAMMING WAVEFORM**

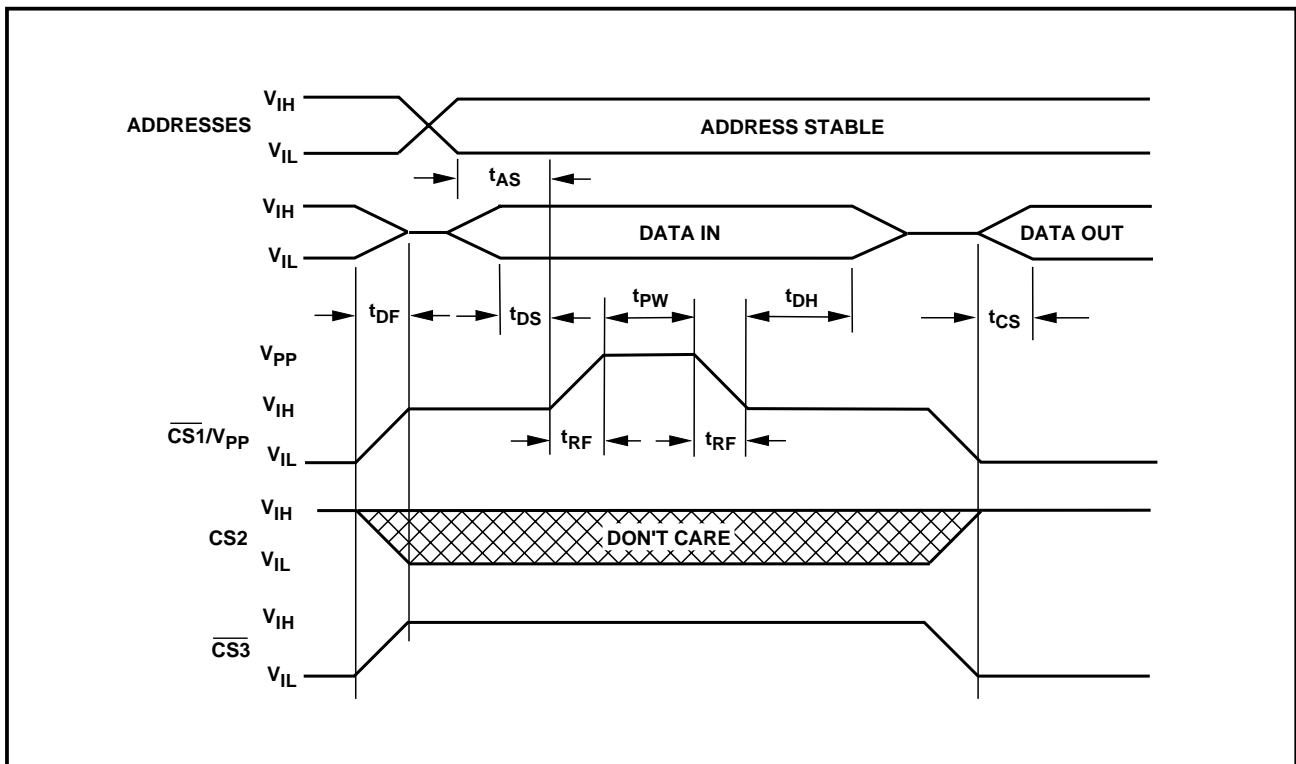

**ORDERING INFORMATION**

PART NUMBER	SPEED (ns)	PACKAGE TYPE	PACKAGE DRAWING	OPERATING TEMPERATURE RANGE	WSI MANUFACTURING PROCEDURE
WS57C71C-35J	35	32 Pin PLDCC	J4	Comm'l	Standard
WS57C71C-35L	35	32 Pin CLDCC	L3	Comm'l	Standard
WS57C71C-35T	35	28 Pin Cerdip, 0.3"	T2	Comm'l	Standard
WS57C71C-45CI	45	32 Pad CLLCC	C2	Industrial	Standard
WS57C71C-45D	45	28 Pin Cerdip, 0.6"	D2	Comm'l	Standard
WS57C71C-45J	45	32 Pin PLDCC	J4	Comm'l	Standard
WS57C71C-45T	45	28 Pin Cerdip, 0.3"	T2	Comm'l	Standard
WS57C71C-45TMB	45	28 Pin Cerdip, 0.3"	T2	Military	MIL-STD-883C
WS57C71C-55CMB	55	32 Pad CLLCC	C2	Military	MIL-STD-883C
WS57C71C-55D	55	28 Pin Cerdip, 0.6"	D2	Comm'l	Standard
WS57C71C-55DMB	55	28 Pin Cerdip, 0.6"	D2	Military	MIL-STD-883C
WS57C71C-55J	55	32 Pin PLDCC	J4	Comm'l	Standard
WS57C71C-55JI	55	32 Pin PLDCC	J4	Industrial	Standard
WS57C71C-55L	55	32 Pin CLDCC	L3	Comm'l	Standard
WS57C71C-55T	55	28 Pin Cerdip, 0.3"	T2	Comm'l	Standard
WS57C71C-55TI	55	28 Pin Cerdip, 0.3"	T2	Industrial	Standard
WS57C71C-55TMB	55	28 Pin Cerdip, 0.3"	T2	Military	MIL-STD-883C
WS57C71C-70L	70	32 Pin CLDCC	L3	Comm'l	Standard
WS57C71C-70T	70	28 Pin Cerdip, 0.3"	T2	Comm'l	Standard
WS57C71C-70TMB	70	28 Pin Cerdip, 0.3"	T2	Military	MIL-STD-883C

**NOTE:** 8. The actual part marking will not include the initials "WS."

**PROGRAMMING/ALGORITHMS/ERASURE/PROGRAMMERS**

**REFER TO  
PAGE 5-1**

The WS57C71C is programmed using Algorithm D shown on page 5-9.

